



**AMI HELIUM VAPOR COOLED CURRENT LEADS
AND SUPERCONDUCTING BUS BARS
INSTALLATION, OPERATION AND
MAINTENANCE INSTRUCTIONS**

American Magnetics, Inc.

PO Box 2509, 112 Flint Road, Oak Ridge, TN 37831-2509, Tel: 865-482-1056, Fax: 865-482-5472



WARNING

DO NOT ATTEMPT TO OPERATE THIS EQUIPMENT UNTIL YOU HAVE READ AND UNDERSTOOD THE CONTENTS OF THIS MANUAL. FAILURE TO DO SO COULD RESULT IN FATAL ELECTRIC SHOCK.

AMI HELIUM VAPOR COOLED CURRENT LEADS AND SUPERCONDUCTING BUS BARS

Installation, Operation and Maintenance Instructions

I. INTRODUCTION

The American Magnetics, Inc. (AMI) helium vapor cooled current leads and superconducting bus bars are designed to introduce high currents into liquid helium environments with a minimum of liquid helium loss. This is accomplished by using the heat capacity of the cold helium boil-off gas to cool the current leads.

II. SPECIFICATIONS

- A. Table 1 lists the specifications and shows dimensional references for AMI standard vapor cooled current leads. Dimensional references in Table 1 are shown on Figure 1. Custom designed or special order current leads may have dimensions and specifications that vary from those listed.
- B. A voltage drop of <0.1 volts per lead at the rated current is typical and should not be exceeded.
- C. A pressure drop of approximately 2mm of mercury (0.03 psi) is developed through the leads at the rated current.
- D. AMI superconducting bus bars (optional) are designed to connect the cold end of the current lead with the magnet terminals. The bus bars are a soldered laminate of Nb₃Sn/Cu and will remain superconducting as long as the bottom end of the bus bar is in contact with liquid helium.

III. INSTALLATION

- A. Carefully remove the current leads from the shipping carton and ensure all packaging material is removed.
- B. Position the current leads into the helium dewar and secure them in position either with the supplied fittings or by bolting through the micarta insulating flange.

CAUTION: *Ensure that the bottom of the current lead tube (vapor inlet) is positioned above the maximum liquid helium level. Operation of the current leads with a liquid helium level above the vapor inlet will result in excessive helium loss and could damage the lead.*

TABLE 1
HELIUM VAPOR COOLED CURRENT LEAD SPECIFICATIONS

Model Number	L-50	L-75	L-100	L-150	L-200	L-250	L-500	L-1000	L-2000	L-3000	L-5000	L-10000	
Amperes	50	75	100	150	200	250	500	1000	2000	3000	5000	10000	
Approx. Helium Consumption, Liters/Hr., (pair of leads)	0.16	0.24	0.32	0.48	0.64	0.8	1.6	3.2	6.4	9.6	16.0	32.0	
Type	A	A	A	A	A	A	A	B	B	B	B	B	
DIMENSIONS IN INCHES	A	1/4	1/4	1/4	1/4	3/8	3/8	1/2	1/2	1/2	1/2	3/4	3/4
	B	1-1/2	1-1/2	1-1/2	1-1/2	2	2	3	3	3	3-3/4	4-1/2	7
	C	1	1	1	1	1-1/4	1-1/4	1-1/2	2	2-1/2	3	3	3-1/2
	D	--	--	--	--	--	--	--	1	1	1-1/2	1-1/2	2
	E	9/32	9/32	9/32	9/32	9/32	9/32	9/16	9/32	7/16	7/16	7/16	7/16
	F	3/8	3/8	3/8	3/8	1/2	1/2	3/4	3/4	3/4	1	1	1 & 3
	G	3/8	3/8	3/8	3/8	1/2	1/2	1/2	7/8	1-1/8	1-1/4	1-1/2	2-1/2
	H	1/4	1/4	1/4	1/4	3/8	3/8	1/2	1/2	3/4	1	1	1-3/4
	I	--	--	--	--	--	--	--	2-1/4	2-1/2	2-5/8	3	3-3/4
	J	--	--	--	--	--	--	--	1-3/4	2	2-1/8	2-1/4	3-1/4
	K	1/4 NPT	1/4 NPT	1/4 NPT	1/4 NPT	3/8 NPT	3/8 NPT	1/2 NPT	1	1-1/4	1-3/8	1-5/8	--
	L	7/8	7/8	7/8	7/8	1	1	1-3/16	5/8	5/8	5/8	5/8	3/8
	M	9/16	9/16	9/16	9/16	9/16	9/16	3/4	3/8	3/8	3/8	3/8	--
	N	--	--	--	--	--	--	--	9/32	9/32	9/32	9/32	9/32
	O	1/4	1/4	1/4	1/4	3/8	3/8	1/2	3/4	1	1-1/8	1-3/8	2-1/8
	R	--	--	--	--	0.201	0.201	0.201	9/32	13/32	17/32	17/32	3/8
	S	1	1	1	1	1	1	1	1-1/2	1-1/2	1-1/2	1-1/2	4
	T	1/16	1/16	1/16	1/16	1/8	1/8	1/8	1/4	1/4	1/4	1/4	3/8
	U	--	--	--	--	1/4	1/4	1/4	1/2	1/2	1/2	1/2	1 & 2-1/2
	V	16-5/8	16-5/8	16-5/8	16-5/8	16-5/8	16-5/8	17-1/2	19-1/2	19-1/2	19-1/2	19-1/2	24
W	Adjust.	Adjust.	Adjust.	Adjust.	Adjust.	Adjust.	Adjust.	1-1/2	2	2	2	4	
X	1/4	1/4	1/4	1/4	3/8	3/8	1/2	3/4	1	1-1/8	1-3/8	2-1/8	
Y	5/8	5/8	5/8	5/8	1/2	1/2	1/2	3/4	1	1	1	1	

Note: Helium consumption is approximately 3.2×10^{-3} liters per hour per ampere for a pair of leads when operated at the rated current. Helium consumption at zero current is approximately 60% of rated current consumption. Consumption rates assume the use of AMI superconducting bus bars and fixed current leads. These specifications do not apply for breakaway current leads. Use of water-cooled cables, resistive bus bars, improperly sized bus bars, or high contact resistance joints may cause consumption rates to be higher than those listed above.

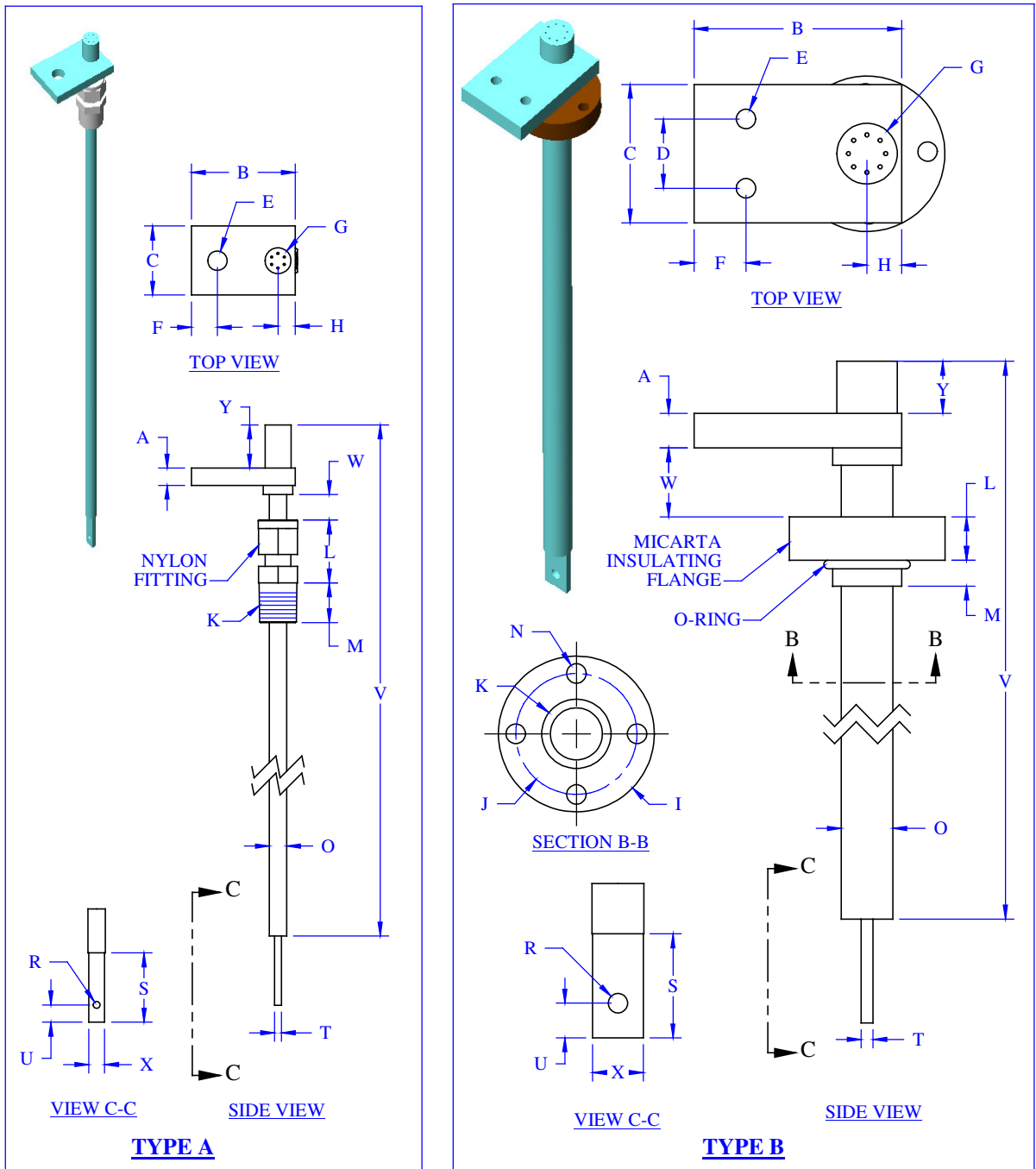

FIGURE 1
DIMENSIONAL REFERENCES FOR STANDARD
HELIUM VAPOR COOLED CURRENT LEADS

- C. Connect the bus bars to the bottom current lug by wrapping the jointed region with a small diameter tinned copper wire. The jointed region can now be soldered using ordinary eutectic lead-tin or other low melting point solder.

CAUTION: *A heat sink should be provided between the bus bar connection and the vapor tube to keep the temperature below 400 °F. The vapor tube is constructed with a tin-silver solder that melts at 430 °F. Temperatures above 430 °F could result in damage to the current lead.*

NOTE: *It is desirable to make as good an electrical connection as possible between the current lead connection flange and the load. A poor electrical connection may cause excessive helium loss.*

- D. Electrical connections to the top current lug should be made by bolting or clamping cables with proper terminations.



WARNING: *Hazardous voltages may be present. Verify all power supplies are de-energized before making or breaking electrical connections. **NEVER** disconnect leads when any current is flowing through them. Attempting to do so could result in FATAL ELECTRIC SHOCK.*



WARNING: *Current leads should be connected and disconnected only by qualified personnel.*

- E. During cooldown, helium gas should be vented through the vapor cooled current leads. A short length of rubber tubing attached to the top of the current lead (vapor outlet), pointed downwards will create a helium gas trap and minimizes the potential for allowing air into the system.

IV. OPERATION

The helium vapor cooled current leads are a passive system component. They are ready to carry the current to the load when properly installed. Upon initial operation and periodically thereafter the helium gas flow through the current leads should be checked and the flow balanced (i.e. equalized). Flow is adjusted by restricting, by any suitable means, the lead with higher gas flow. During normal operation, a small amount of ice or frost may develop around the top of the current lead.

The voltage across each lead (from the top of the lead to the appropriate magnet terminal) may be monitored to avoid operating with an overheated condition. A voltage drop of <0.1 volt per lead at the rated current is typical and should not be exceeded.

V. BREAKAWAY CURRENT LEADS

Break-away vapor cooled current leads (Figure 2) represent a popular configuration for long-term, persistent magnet operation. Break-away leads are supplied in two sections so that the upper section can be disconnected from the lower section during persistent magnet operation. Helium consumption is significantly reduced because the 300K to 4K thermal conduction path through the current leads is eliminated.

A. DISCONNECTING THE CURRENT LEADS:



WARNING: *All AMI current leads are designed to be connected and disconnected with **zero current flow**. **NEVER** connect or disconnect current leads while any current is flowing through them. Attempting to do so could result in **FATAL ELECTRIC SHOCK**.*



WARNING: *Breakaway leads should be connected and disconnected only by qualified personnel.*

1. Ensure a zero current state exists and verify with an appropriate instrument.
2. Disconnect power supply cables from the warm terminals of the breakaway current leads.
3. Loosen the brass fitting on the upper section of the breakaway current lead. It may be necessary to warm the fitting with a heat gun to melt any ice or frost which may be present.
4. Lift up on the upper section of the breakaway current lead, while slightly rotating it back and forth. You should be able to feel the current lead disconnect from the lower section. (Do not use excessive force if the current lead cannot be disconnected as ice may be present at the connection point. Ice can be removed by flowing room temperature helium gas through the top of the lead into the cryostat where the connection is located.)
5. At this point the current lead can be lifted another few inches and the fitting can be re-tightened. (Alternatively, the current lead can be completely removed and replaced with NPT pipe plugs.)
6. Seal off the vapor exhaust from the current leads to prevent air from entering the cryostat. This could cause ice formation on the male connector and make reconnection of the current lead difficult or impossible.

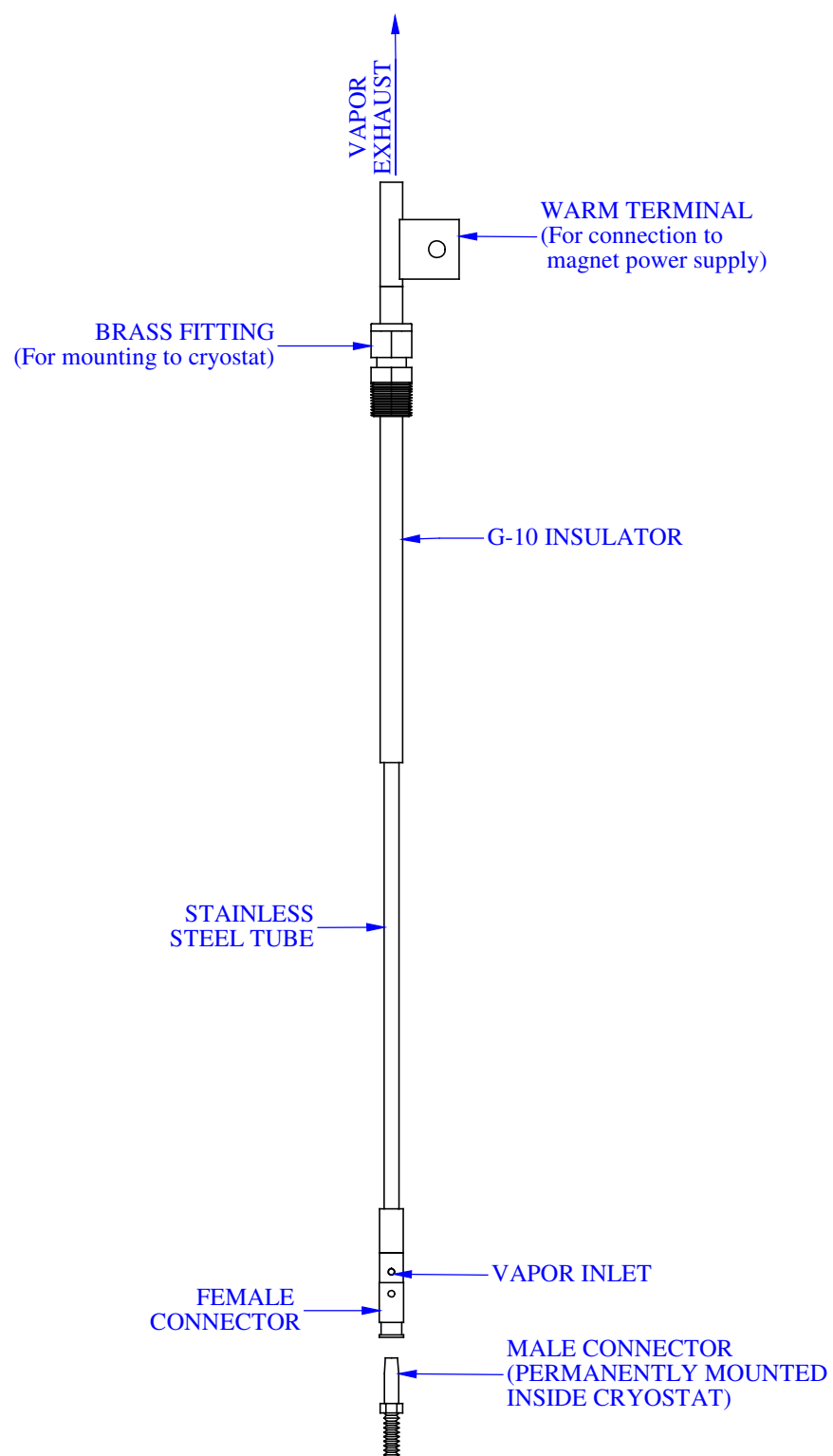

FIGURE 2
STANDARD BREAKAWAY
CURRENT LEADS

B. RECONNECTING THE CURRENT LEADS



WARNING: All AMI current leads are designed to be connected and disconnected with **zero current flow**. **NEVER** disconnect these leads when any current is flowing in them. Attempting to do so could result in **FATAL ELECTRIC SHOCK**.



WARNING: Breakaway leads should be connected and disconnected only by qualified personnel.

1. Unseal the vapor exhaust on the current leads to ensure proper cooling of the leads. This will also allow pre-cooling of the current leads.



WARNING: Attempting to reconnect warm breakaway leads to a superconducting magnet in persistent mode could heat the magnet and cause a quench. **Dangerously high voltages can be present during a magnet quench that can cause FATAL ELECTRIC SHOCK.**

2. Loosen the fitting on the upper section of the breakaway current lead.
3. Gently push down on the upper section of the breakaway current lead while slightly rotating it back and forth. You should be able to feel the current lead female connector engage the lower section male connector. (Do not use excessive force if the male connector cannot be engaged as ice may be present on the male connector. Ice can be removed by flowing room temperature helium gas through the top of the lead down into the cryostat where the male connector is located.)
4. Tighten the brass fitting on the upper section of the breakaway current lead.
5. Reconnect power supply cables to the warm terminals of the breakaway leads.

VI. MAINTENANCE

Generally the vapor cooled current leads are maintenance-free. Periodically check the current leads to ensure that helium gas vapor is flowing through the leads and they have not become plugged. The leads are sealed, passive units and repair, other than by factory authorized personnel, is not recommended.

VII. TROUBLESHOOTING

If you have any questions, please contact an Authorized AMI Technical Support Representative at (865) 482-1056, or by email: support@americanmagnetics.com

VIII. WARRANTY

All products manufactured by AMI are warranted to be free of defects in materials and workmanship and to perform as specified for a period of one year from date of shipment. In the event of failure occurring during normal use, AMI, at its option, will repair or replace all products or components that fail under warranty, and such repair or replacement shall constitute a fulfillment of all AMI liabilities with respect to its products. Since, however, AMI does not have control over the installation conditions or the use to which its products are put, no warranty can be made of fitness for a particular purpose, and AMI cannot be liable for special or consequential damages. All repairs are F.O.B. Oak Ridge, Tennessee, USA. If the repairs are covered under this warranty then standard shipping for return to the customer is paid for by AMI within the USA.

IX. PRODUCT LIABILITY DISCLAIMER

Due to the fact that AMI does not have control over the installation conditions or use of its products, no warranty can be made of fitness for a particular purpose. AMI cannot be liable for special or consequential damages that may occur for these reasons.

X. RETURN AUTHORIZATION

Items to be returned to AMI for repair (warranty or otherwise) require a Return Authorization number to ensure your order will receive the proper attention. Please call an AMI representative at (865) 482-1056 for a Return Authorization number prior to shipping any item back to AMI.