

MODEL 4Q12125PS-430 HIGH STABILITY INTEGRATED POWER SUPPLY SYSTEM

INSTALLATION, OPERATION, AND MAINTENANCE INSTRUCTIONS

American Magnetics, Inc.

P.O. Box 2509, 112 Flint Road, Oak Ridge, TN 37831-2509, Tel: 865-482-1056, Fax: 865-482-5472

Table of Contents

Table of Contents	iii
List of Figures	ix
List of Tables	xi
Foreword	xiii
Purpose and Scope	xiii
Contents of this Manual	xiii
General Precautions.....	xiv
Safety Summary.....	xvi
Introduction	1
1.1 Model 4Q12125PS-430 Integrated Power Supply System Features ..	1
1.1.1 Digitally-Controlled.....	1
1.1.2 Superior Resolution and Stability	1
1.1.3 Intuitive Human-Interface Design.....	1
1.1.4 Flexibility.....	2
1.1.5 Standard Remote Interfaces.....	2
1.1.6 Programmable Safety Features.....	2
1.1.7 Condition-Based Magnet Auto-Rampdown.....	2
1.1.8 Model 4Q12125PS-430 General Description.....	3
1.1.9 Power Supply System Rack Front Panel Layout	4
1.2 Model 430 Front Panel Layout.....	5
1.3 Model 430 Rear Panel Layout	6
1.4 Power Supply Unit Front Panel Layout	7
1.5 System Specifications @ 25°C	8
1.6 Operating Characteristics	9
1.6.1 Four-Quadrant Operation.....	9
Installation	11
2.1 Inspecting and Unpacking.....	11
2.2 Power Supply System Mounting.....	11
2.3 Power Requirements	12
2.3.1 Changing the Model 430 Programmer Operating Voltage ...	12
2.4 Collecting Necessary Information.....	12
2.5 System Interconnects.....	13
2.5.1 High-Current, High-Stability 4-Quadrant Supply	13

Table of Contents

2.6	Special Configurations.....	16
2.7	Superconducting Magnets with No Persistent Switch	16
2.8	Short-Circuit or Resistive Load.....	17
2.9	Power-Up and Test Procedure	17
	Operation.....	21
3.1	System Power On/Off Sequence	21
3.1.1	Model 430 Programmer Power On/Off.....	21
3.1.2	Energizing Power Supply and Components	22
3.2	Model 430 Programmer Default Display	23
3.2.1	Field / Current Display	23
3.2.2	Voltage Display	24
3.2.3	Status Indicator	24
3.2.4	Main Display	25
3.3	Entering Numeric Values.....	25
3.4	Using Fine Adjust Knob to Adjust Numeric Values	26
3.5	Entering Picklist Values.....	27
3.6	Single-key Commands / Menu.....	28
3.6.1	Persistent Switch Control Key	29
3.6.2	Target Field Setpoint Key	31
3.6.3	Ramp / Pause Key	31
3.6.4	Ramp To Zero Key.....	31
3.7	SHIFT-key Commands / Menus.....	32
3.7.1	Ramp Rate SHIFT-key	33
3.7.2	Voltage Limit SHIFT-key	36
3.7.3	Reset Quench SHIFT-key	37
3.7.4	Increment Field SHIFT-key	37
3.7.5	Field <> Current SHIFT-key.....	38
3.7.6	Decrement Field SHIFT-key	38
3.7.7	Field Units SHIFT-key	38
3.7.8	Persistent Switch Heater Current SHIFT-key.....	39
3.7.9	Stability SHIFT-key.....	39
3.7.10	Vs <> Vm SHIFT-key.....	39
3.7.11	Volt Meter SHIFT-key	39
3.7.12	Fine Adjust SHIFT-key.....	39
3.7.13	Persist. Switch Control SHIFT-key	39
3.8	LED Indicators.....	40
3.8.1	Power-on Indicator.....	40
3.8.2	Magnet Status Indicators	40
3.8.3	SHIFT Indicator.....	41

Table of Contents

3.9	Setup Menu	41
3.9.1	Entering / Exiting Setup Menu	41
3.9.2	Menu Navigation.....	42
3.10	Setup Submenu Descriptions	42
3.10.1	Supply Submenu	43
3.10.2	Load Submenu.....	48
3.10.3	Misc Submenu	59
3.10.4	Net Settings Submenu	68
3.10.5	Net Setup Submenu	70
3.11	Example Setup	72
3.12	Ramping Functions	74
3.12.1	Ramping States and Controls	75
3.12.2	Manual Ramping.....	76
3.12.3	Automatic Ramping	76
3.12.4	Ramping to Zero	77
3.12.5	Fine Adjust of Field / Current in Holding Mode.....	77
3.13	Persistent Switch Control.....	77
3.13.1	Procedure for Initial Heating of the Switch	78
3.13.2	Procedure for Entering Persistent Mode	78
3.13.3	Procedure for Exiting Persistent Mode	81
3.13.4	Toggling the State of the Persistent Switch Heater.....	84
3.14	Ramping Functions Example	85
3.15	Quench Detection	86
3.15.1	External Quench Detection.....	87
3.15.2	Disabling Internal Quench Detection	88
3.16	External Rampdown	88
3.16.1	External Rampdown while in Persistent Mode	89
3.16.2	External Rampdown while not in Persistent Mode	90
3.17	Summary of Operational Limits and Default Settings.....	90
	Remote Interface Reference	93
4.1	SCPI Command Summary	93
4.2	Programming Overview.....	100
4.2.1	SCPI Language Introduction.....	100
4.2.2	SCPI Status System.....	100
4.2.3	Standard Event Register	103
4.2.4	Command Handshaking	104
4.3	RS-232 Configuration	106
4.3.1	Serial Connector.....	106
4.3.2	Termination Characters.....	106

Table of Contents

4.4	Ethernet Configuration	106
4.4.1	Ethernet Connector.....	107
4.4.2	Termination Characters	107
4.5	Command Reference	108
4.5.1	System-Related Commands.....	108
4.5.2	Status System Commands.....	109
4.5.3	SETUP Configuration Commands and Queries	110
4.5.4	Protection Commands and Queries.....	115
4.5.5	Ramp Configuration Commands and Queries.....	120
4.5.6	Ramping State Commands and Queries.....	124
4.5.7	Switch Heater Command and Query	125
4.5.8	Quench State Commands and Queries	126
4.5.9	Rampdown State Queries	126
4.5.10	Trigger Functions.....	128
4.6	Error Messages	130
4.6.1	Command Errors.....	130
4.6.2	Query Errors	131
4.6.3	Execution Errors	132
4.6.4	Device Errors.....	132
	Service	135
5.1	System Component Maintenance	135
5.1.1	Model 430 Programmer Routine Maintenance.....	135
5.1.2	Model 4Q12125PS Power Supply Routine Maintenance	135
5.2	Troubleshooting Hints	135
5.2.1	Electrostatic Discharge Precautions	135
5.2.2	The Model 430 does not appear to be energized.....	136
5.2.3	FAILURE TO LOAD message displayed after power-up	137
5.2.4	Power supply unstable - magnet voltage oscillates.....	138
5.2.5	The power supply system will not charge the magnet.....	138
5.2.6	Cannot charge the magnet at the selected ramp rate.....	139
5.2.7	Cannot discharge the magnet at the selected ramp rate.....	139
5.2.8	Cannot charge the magnet to desired field.....	139
5.2.9	Current in only one direction from 4-quadrant supply	139
5.2.10	Cannot place the magnet in persistent mode.	139
5.2.11	Cannot bring the magnet out of persistent mode.....	140
5.2.12	The magnet quenches for no apparent reason.....	140
5.2.13	Cannot lower the magnet field	140
5.2.14	There is excessive LHe boil-off during operation.	141
5.2.15	Cannot display the magnetic field strength, only current...	141
5.2.16	Cannot use remote communications commands.	142
5.2.17	Magnet current drifts unacceptably while PSwitch cooling	142
5.2.18	Model 430 appears to lock up when connecting to network	142

Table of Contents

5.3	Additional Technical Support.....	143
5.4	Return Authorization.....	143
	Appendix.....	145
A.1	Magnet Station Connectors	145
A.2	LHe Level / Temp Connectors	146
A.3	Current Transducer Signal Connector	147
A.4	Current Transducer Power Connector	148
A.5	Program Out Connector	149
A.6	Quench I/O Connector.....	150
A.6.1	External Quench Detection Input	150
A.6.2	External Rampdown Input	151
A.6.3	External Quench Detection Output	152
A.7	Aux Inputs Connector.....	153
A.8	Ethernet Connector	154
A.9	RS-232 Connector.....	154
A.10	Abbreviations and Acronyms used in this Manual	155
A.11	Model 430 Programmer Specifications	159
A.12	Power Supply Details.....	161
A.12.1	Model 4Q06125PS Single Unit Electrical Specifications	162
A.12.2	Model 4Q06125PS Single Unit Dimensional Specifications	165
A.12.3	Four-Quadrant Characteristics	166
A.13	Remote Computer Communication with the Model 430.....	167
A.13.1	Communication via RS-232	167
A.13.2	Communication via Ethernet	170
A.14	Upgrading the Model 430 Firmware via FTP	173
A.14.1	Hardware and Software Requirements.....	173
A.14.2	Preparation.....	174
A.14.3	Procedure	175
A.15	Upgrading the Model 430 Firmware via Flash Card Reader	180
A.15.1	Hardware and Software Requirements.....	180
A.15.2	Preparation.....	180
A.15.3	Procedure	181
A.16	Model 430 Remote Control Application	184
A.17	Model 430IP Power Supply Programmer	187
A.18	Persistent Switch Operation Flowchart	190
	Index	193

Table of Contents

List of Figures

Figure 1-1	Typical Model 4Q12125PS-430 System Rack Layout	4
Figure 1-2	Model 4Q06125PS Front Panel.....	7
Figure 1-3	The Four Regions, or Quadrants, of System Operation.	9
Figure 1-4	Four-Quadrant System with Resistive Shunt.....	9
Figure 1-5	Four-Quadrant System with Precision Current Transducer Option..	10
Figure 2-1	Model 4Q12125PS-430 High-Stability System Interconnects.....	14
Figure 3-1	Default Display.	23
Figure 3-2	Numeric Keypad and Associated Keys	25
Figure 3-3	Menu Navigation Keys	28
Figure 3-4	Single Input Keys	29
Figure 3-5	SHIFT-Key Functions	32
Figure 3-6	Magnet Status LED Indicators.....	40
Figure 3-7	Setup Menu Structure	43
Figure 3-8	Example Power Supply Outputs.....	46
Figure 3-9	Stability Setting vs. Magnet (with PSwitch) Inductance	49
Figure 3-10	Typical Power Supply Self-Limits	51
Figure 3-11	Magnet Current Rating Set Within Supply Range.....	52
Figure 3-12	Example Current Limit Setup	53
Figure 3-13	Example Magnet Specification Sheet.	73
Figure 3-14	Ramping to Two Different Target Field/Current Settings.....	85
Figure 4-1	The Model 430 Programmer Status System.	101
Figure 4-2	Asterisk Indicating Model 430 in Remote Mode	109
Figure A-1	4Q06125PS Outline Drawing, Front and Rear Views	165
Figure A-2	4Q06125PS Outline Drawing Top and Side Views.....	166
Figure A-3	Four-Quadrant Supply Output Characteristics.....	167
Figure A-4	http:// - IP Address or System Name Entry	185
Figure A-5	Initial Screen for Browser Access of the Model 430.....	186
Figure A-6	Model 430IP Front Panel	187
Figure A-7	Browser Depiction of the Model 430	187
Figure A-8	http:// - System Name Entry	188
Figure A-9	Initial Screen for Browser Access of the Model 430IP.....	188
Figure A-10	Browser Control of the Model 430IP	189
Figure A-11	Persistent Switch Operation Flowchart, Page 1	190
Figure A-12	Persistent Switch Operation Flowchart, Page 2	191
Figure A-13	Persistent Switch Operation Flowchart, Page 3	192

List of Figures

List of Tables

Table 1-1	Model 430 Front Panel Description	5
Table 1-2	Model 430 Zero Flux Version Rear Panel Description.....	6
Table 1-3	Power Supply Front Panel Controls and Indicators	7
Table 3-1	Description of Status Indicators	24
Table 3-2	Select Supply picklist values and associated parameters.	45
Table 3-3	V-V Mode Input Range Picklist Values	48
Table 3-4	Maximum Recommended Stability Setting Changes	50
Table 3-5	Example Setup Configuration.....	74
Table 3-6	Ramp modes and descriptions.....	76
Table 3-7	Summary of Model 430 Programmer Limits and Defaults	91
Table 4-1	Bit Definitions for the Status Byte Register	102
Table 4-2	Bit Definitions for the Standard Event Register	104
Table 4-3	Return Values and Meanings for SUPPLY:TYPE? Query	111
Table 4-4	Return Values and Meanings for SUPPLY:MODE? Query.....	112
Table 4-5	Return Values and Meanings for STATE? Query.....	125
Table 4-6	Model 430 Programmer Trigger Function Bit Definitions	128
Table 5-1	V-V Mode Input Range Picklist Values	137
Table A-1	Magnet Station Connectors Pin Definitions.....	145
Table A-2	LHe Level / Temp Connectors Pin Definitions.....	146
Table A-3	Current Transducer Signal Connector Pin Definitions	147
Table A-4	Current Transducer Power Connector Pin Definitions	148
Table A-5	Program Out Connector Pin Definitions	149
Table A-6	Quench I/O Connector Pin Definitions	150
Table A-7	Aux Inputs Connector Pin Definitions	153
Table A-8	Ethernet RJ-45 Connector Pin Definitions	154
Table A-9	RS-232 Connector Pin Definitions	154
Table A-10	PC (DB9)-to-Model 430 RS-232 Cable Connections.....	155
Table A-11	Abbreviations and Acronyms	155
Table A-12	Model 430 Programmer Specifications @ 25°C	159
Table A-13	Model 4Q06125PS Electrical Specifications.....	162

List of Tables

Foreword

Purpose and Scope

This manual contains the operation and maintenance instructions for the American Magnetics, Inc. Model 4Q12125PS-430 High-Stability Power Supply System with zero flux current sensing system. The user is encouraged to contact an authorized AMI Technical Support Representative for information regarding specific configurations not explicitly covered in this manual.

Contents of this Manual

Introduction introduces the reader to the functions and characteristics of the Model 430 Power Supply Programmer and the Power Supply System. It provides illustrations of the front and rear panel layouts as well as documenting the performance specifications. Additional information is provided in the form of system circuit diagrams.

Installation describes how the Model 430 Power Supply Programmer is unpacked and installed in conjunction with ancillary equipment in typical superconducting magnet systems. Block-level diagrams document the interconnects for various system configurations.

Operation describes how the Model 430 Programmer is used to control a superconducting magnet. *All* Model 430 Programmer displays and controls are documented. The ramping functions, persistent switch heater controls, and the quench detect features are also presented.

Remote Interface Reference documents all remote commands and queries available through the Model 430 Programmer RS-232 and Ethernet interfaces. A quick-reference summary of commands is provided as well as a detailed description of each.

Service provides guidelines to assist the user in troubleshooting possible system and Model 430 Programmer malfunctions. Information for contacting AMI Technical Support personnel is also provided.

Appendix provides additional details and/or procedures in the following areas:

1. Model 430 Programmer rear panel connectors.
2. Individual power supply unit specifications

Foreword

General Precautions

3. Establishing RS-232 or Ethernet communications with the Model 430.
4. Model 430 firmware upgrade.
5. Abbreviations and acronyms used in this manual.
6. Persistent switch operation (flow diagram).

General Precautions

Cryogen Safety

The two most common cryogenic liquids used in superconducting magnet systems are nitrogen and helium. Both of these cryogens are extremely cold at atmospheric pressure (-321°F and -452°F , respectively). The following paragraphs outline safe handling precautions for these liquids.

Personnel handling cryogenic liquids should be thoroughly instructed and trained as to the nature of the liquids. Training is essential to minimize accidental spilling. Due to the low temperature of these materials, a cryogen spilled on many objects or surfaces may damage the surface or cause the object to shatter, often in an explosive manner.

Inert gases released into a confined or inadequately ventilated space can displace sufficient oxygen to make the local atmosphere incapable of sustaining life. Liquefied gases are potentially extreme suffocation hazards since a small amount of liquid will vaporize and yield a very large volume of oxygen-displacing gas. Always ensure the location where the cryogen is used is well ventilated. Breathing air with insufficient oxygen content may cause unconsciousness without warning. If a space is suspect, purge the space completely with air and test before entry. If this is not possible, wear a forced-air respirator and enter only with a co-worker standing by wearing a forced-air respirator.

Cryogenic liquids, due to their extremely low temperatures, will also burn the skin in a similar manner as would hot liquids. Never permit cryogenic liquids to come into contact with the skin or allow liquid nitrogen to soak clothing. Serious burns may result from careless handling. Never touch uninsulated pipes or vessels containing cryogenic liquids. Flesh will stick to extremely cold materials. Even nonmetallic materials are dangerous to touch at low temperatures. The vapors expelled during the venting process are sufficiently cold to burn flesh or freeze optic tissues. Insulated gloves should be used to prevent frost-bite when operating valves on cryogenic tanks. Be cautious with valves on cryogenic systems; the temperature extremes they are typically subjected to cause seals to fail frequently.

Foreword

General Precautions

In the event a person is burned by a cryogen or material cooled to cryogenic temperatures, the following first aid treatment should be given pending the arrival and treatment of a physician or other medical care worker:

1. If any cryogenic liquid contacts the skin or eyes, immediately flush the affected area gently with tepid water (102°F – 105°F, 38.9°C – 40.5°C) and then apply cold compresses.
2. Do not apply heat. Loosen any clothing that may restrict circulation. Apply a sterile protective dressing to the affected area.
3. If the skin is blistered or there is any chance that the eyes have been affected, get the patient immediately to a physician for treatment.

Containers of cryogenic liquids are self pressurizing (as the liquid boils off, vapor pressure increases). Hoses or lines used to transfer these liquids should never be sealed at both ends (i.e. by closing valves at both ends).

When pouring cryogenic liquids from one container to another, the receiving container should be cooled gradually to prevent damage by thermal shock. The liquid should be poured slowly to avoid spattering due to rapid boil off. The receiving vessel should be vented during the transfer.

Introduction of a substance at or near room temperature into a cryogenic liquid should be done with great caution. There may be a violent gas boil-off and a considerable amount of splashing as a result of this rapid boiling. There is also a chance that the material may crack or catastrophically fail due to forces caused by large differences in thermal contraction of different regions of the material. Personnel engaged in this type of activity should be instructed concerning this hazard and should always wear a full face shield and protective clothing. If severe spraying or splashing could occur, safety glasses or chemical goggles along with body length protective aprons will provide additional protection.

The properties of many materials at extremely low temperatures may be quite different from the properties that these same materials exhibit at room temperatures. Exercise extreme care when handling materials cooled to cryogenic temperatures until the properties of these materials under these conditions are known.

Metals to be used for use in cryogenic equipment application must possess sufficient physical properties at these low temperatures. Since ordinary carbon steels, and to somewhat a lesser extent, alloy steels, lose much of their ductility at low temperatures, they are considered unsatisfactory and sometimes unsafe for these applications. The austenitic Ni-Cr alloys exhibit good ductility at these low temperatures and the most widely used

is 18-8 stainless steel. Copper, Monel[®], brass and aluminum are also considered satisfactory materials for cryogenic service.

Magnet Quenches

When an energized superconducting magnet transitions from superconducting state to normal state, the magnet converts magnetic energy to thermal energy thereby rapidly converting the liquid helium to a vapor. When this phase transformation occurs, pressures can build rapidly in the cryostat due to the fact that one part of liquid helium will generate 782 parts of gaseous helium at STP (standard temperature and pressure). The cryostat must be designed to allow the generated vapor to rapidly and safely vent to an area of lower pressure. Cryostats are designed with pressure relief valves of sufficient capacity so as to limit the pressure transients within the container in order to prevent damage to the vessel. Operating a superconducting magnet in a cryostat without properly sized relief mechanisms or disabled relief mechanism is unsafe for the operator as well as for the equipment. If there is any doubt as to the sufficiency of the pressure relief system, contact the manufacturer of the magnet and cryostat for assistance.

Safety Summary

Superconducting magnet systems are complex systems with the potential to seriously injure personnel or equipment if not operated according to procedures. The use of cryogenic liquids in these systems is only one factor to consider in safe and proper magnet system operation. Proper use of safety mechanisms (pressure relief valves, rupture disks, etc.) included in the cryostat and top plate assembly are necessary. Furthermore, an understanding of the physics of the magnet system is needed to allow the operator to properly control the large amounts of energy stored in the magnetic field of the superconducting coil. The Model 430 Programmer has been designed with safety interlocks to assist the operator in safe operation, but these designed-in features cannot replace an operator's understanding of the system to ensure the system is operated in a safe and deliberate manner.

Recommended Safety Equipment

- First Aid kit
- Fire extinguisher rated for class C fires
- Cryogenic gloves
- Face shield
- Signs to indicate that there are potentially damaging magnetic fields in the area and that cryogenics are in use in the area.

Safety Legend



Instruction manual symbol: the product is marked with this symbol when it is necessary for you to refer to the instruction manual in order to protect against damage to the product or personal injury.



Hazardous voltage symbol.



Alternating Current (Refer to IEC 417, No. 5032).



Off (Supply) (Refer to IEC 417, No. 5008).



On (Supply) (Refer to IEC 417, No. 5007).

Warning

The Warning sign denotes a hazard. It calls attention to a procedure or practice, which if not correctly adhered to, could result in personal injury. Do not proceed beyond a Warning sign until the indicated conditions are fully understood and met.

Caution

The Caution sign denotes a hazard. It calls attention to an operating procedure or practice, which if not adhered to, could cause damage or destruction of a part or all of the product. Do not proceed beyond a Caution sign until the indicated conditions are fully understood and met.

1 Introduction

1.1 Model 4Q12125PS-430 Integrated Power Supply System Features

The AMI Model 4Q12125PS-430 High-Stability Power Supply System is a sophisticated digitally-controlled power supply which allows an operator to manage a superconducting magnet system with unprecedented accuracy and ease of use. Integral components of the system include a Model 430 Programmer with zero flux current sensing system and two Model 4Q06125PS Power Supplies. The AMI Model 4Q12125PS-430 Power Supply System provides for a degree of flexibility and accuracy previously unavailable in an economical commercial product.

1.1.1 Digitally-Controlled

The Power Supply System is controlled by a microcomputer-based controller which controls all analog data conversion, display/keypad functions, communications I/O, generation of analog programming signals for the external power supply, and control law computations. The Power Supply System incorporates digital signal processing (DSP) functions that provide for accurate control, low drift, and flexibility of use.

1.1.2 Superior Resolution and Stability

The Model 430 Power Supply Programmer incorporates high-resolution converters to translate signals between the analog and digital domains. Precision instrumentation techniques and potentiometer-free designs are employed throughout the Model 430 Programmer to ensure accurate signal translation for a wide range of conditions. The magnet current is sampled at 24-bit resolution in hardware and is software-programmable to 15-digits resolution. All pause and hold functions are performed in the digital domain which provides for excellent stability and drift of the programmed magnetic field.

For greater stability and accuracy, the Model 430 Programmer is configured with a zero-flux precision current measuring device instead of the standard resistive shunt. This option typically increases the system stability and accuracy by an order of magnitude. The power supply systems incorporating this technique are referred to as “high-stability” systems.

1.1.3 Intuitive Human-Interface Design

The Power Supply System was designed to simplify the interface where possible. All functions were analyzed and subsequently programmed so that the most commonly used functions are addressed with the least

Introduction

Features

number of keystrokes. The menus are also presented in a logical fashion so that the operation of the Power Supply System is intuitive to the user.

The provision of a velocity-sensitive rotary encoder on the front panel also allows the operator to fine-adjust many of the operating parameters of the magnet system.

1.1.4 Flexibility

The Model 4Q12125PS-430 system is configured as a four-quadrant high-stability power supply system which is able to both supply and remove electrical energy from the superconducting magnet system. The Power Supply System was engineered to be compatible with most magnet systems.

1.1.5 Standard Remote Interfaces

The Power Supply System provides an RS-232 serial port as well as an Ethernet port as standard features. All settings can be controlled via the remote interfaces and the front panel can be remotely locked to prevent accidental operation. The Power Supply System also provides trigger functions for data collection and/or logging during operation.

1.1.6 Programmable Safety Features

The Power Supply System is designed to be operated from the front panel of the Programmer or remotely with operational parameters which must not be exceeded for the given conditions of the system. Once set, should an operator inadvertently attempt to take the magnet system to an excessive magnetic field strength or charge at an excessive voltage, the Programmer will not accept the parameter and will alert the operator that a value was rejected because it was outside the user-defined limits.

In addition, each setup parameter can be individually selected for locking. A user-defined password is required to lock or unlock settings. This allows an administrator to set and password protect any critical parameters that should not be changed by the operator. Then the administrator can be confident that an operator will not subsequently change any of these critical parameters, and yet will be free to change any non-critical (unlocked) parameters.

1.1.7 Condition-Based Magnet Auto-Rampdown

The Power Supply System can be connected to an AMI Model 13x Liquid Helium Level Instrument to allow automatic rampdown of the magnet (even in persistent mode) should the liquid helium (LHe) level drop to a preset level. This feature ensures the magnet will be protected and not experience a quench should the LHe level reach an unsafe level for magnet operation. A single cable is required to use this feature and is covered in

Introduction

General Description

more detail in section A.6.2 on page 151 of the Appendix. Contact AMI for more information.

In addition to low LHe level, this input to the Power Supply System can be used with other instrumentation as well. Other uses for this input include faults from a cryocooler, temperature instrumentation, etc.

1.1.8 Model 4Q12125PS-430 General Description

A Model 430 Power Supply Programmer and two Model 4Q06125PS Power Supplies are configured to make up the system designated as 4Q12125PS-430. The Model 4Q06125PS is a 750 Watt, ± 6 Volt, ± 125 ampere, 4-quadrant, voltage and current stabilized DC supply. Two Model 4Q06125PS Power Supplies are connected in a Master/Slave series configuration to provide the rated voltage. The power supplies are remotely controlled by the Model 430 Power Supply Programmer.

The Model 4Q12125PS-430 is a true 4-quadrant voltage and current power supply capable of both sourcing and sinking¹ power smoothly through zero to provide true \pm voltage and \pm current. It is ideal for controlling inductive loads such as large magnets or motors.

The power supplies are controlled by a ± 10 Vdc remote analog signal supplied by the Model 430 Programmer and applied to the power supply analog inputs. Programming and control of the current loop (composed of the magnet, power supplies, and Model 430 Programmer zero flux device), is provided by a Model 430 ramp-generated current reference with parameters as set by the user in the Model 430. The Model 430 compares the measured current (via the zero flux device) with the current reference to provide precise closed-loop control of the actual current.

The power supply units are operated in voltage-voltage² programming mode, with the Model 430 Programmer output scaled to operate the power supply units over their available voltage output range. The Programmer signal will continually adjust the power supply output voltage to automatically regulate the power supply current; precise linear power supply current control will result as long as the system voltage and current demand do not exceed the total power supply rating or load limiting parameters.

-
1. The power supply is operating as a source if the current direction and voltage polarity are the same (i.e., the situation that would exist when supplying a resistive load). If the voltage polarity and current direction are opposite, the supply is operating as a sink and energy is being absorbed or returned to the "ac-line".
 2. Voltage reference controlling voltage output.

Introduction

System Rack

1.1.9 Power Supply System Rack Front Panel Layout

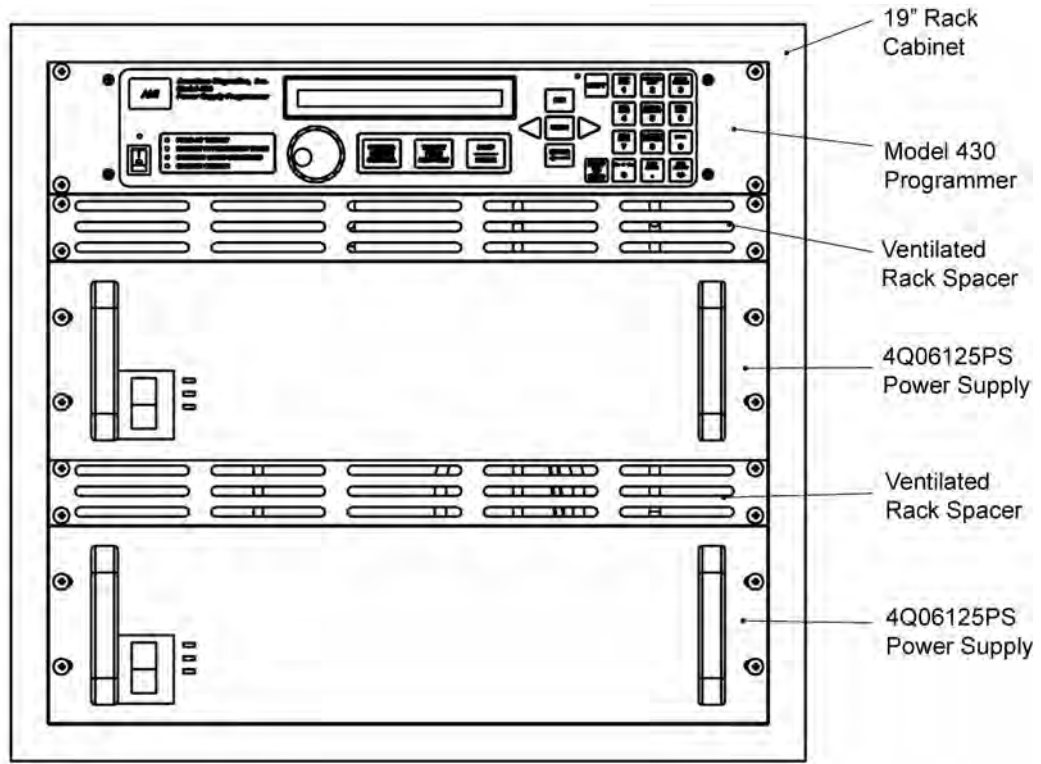
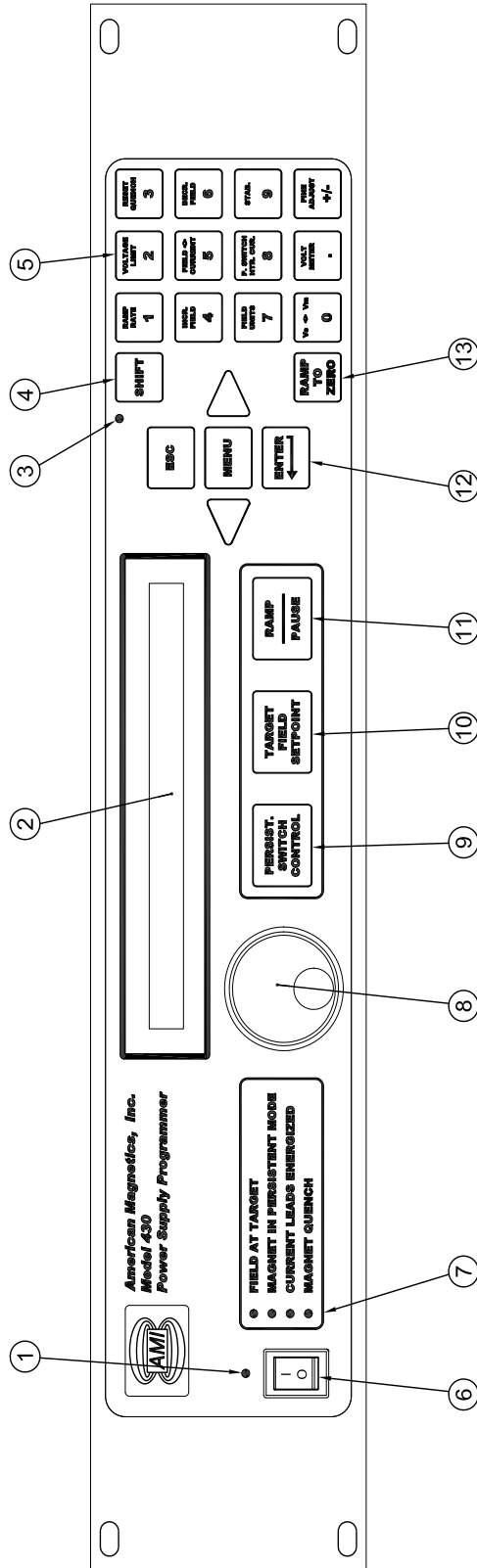

Figure 1-1. Typical Model 4Q12125PS-430 System Rack Layout

1.2 Model 430 Front Panel Layout



1 Power Indicator LED	8 Fine Adjust Knob
2 280 x 16 Dot Graphic VF Display	9 Persistent Switch Heater Control Key
3 Shift Indicator LED	10 Target Field Setpoint Key
4 Shift Key	11 Ramp/Pause Switch
5 4 Row x 3 Column Keypad	12 Menu Navigation and Data Entry Keys
6 Power Switch	13 Ramp to Zero Key
7 Magnet Status Indicator LEDs	

Table 1-1. Model 430 Front Panel Description

Introduction

Model 430 Rear Panel Layout

1.3 Model 430 Rear Panel Layout

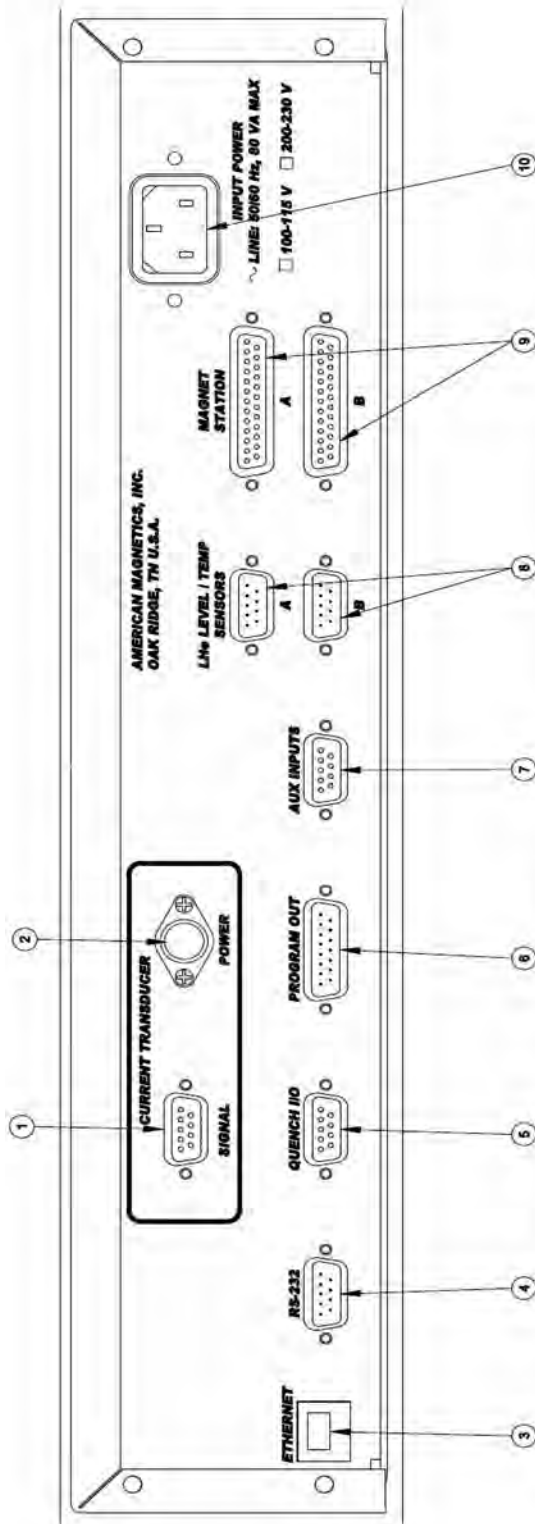

1	Current Transducer 9-pin Female D-sub Connector	6	Program Out 15-pin Male D-sub Connector
2	Current Transducer 8-pin DIN Power Connector	7	Aux Inputs 15-pin Female HD D-sub Connector
3	Ethernet RJ-45 Connector	8	Dual Auxiliary LHe Level/Temp 9-pin Male D-sub Connectors
4	RS-232 9-pin Male D-sub Connector	9	Dual Magnet Station 25-pin Female D-sub Connectors
5	Quench I/O 9-pin Female D-sub Connector	10	Input Power IEC 60320 C14 Male Connector

Table 1-2. Model 430 Zero Flux Version Rear Panel Description

Introduction

Power Supply Front Panel Layout

1.4 Power Supply Unit Front Panel Layout

The power supply individual front panels contain the input ON/OFF circuit breakers and the FAULT, MASTER / STANDALONE and SLAVE indicators. Refer to Figure 1-2 and Table 1-3. for a description of front panel controls and indicators.

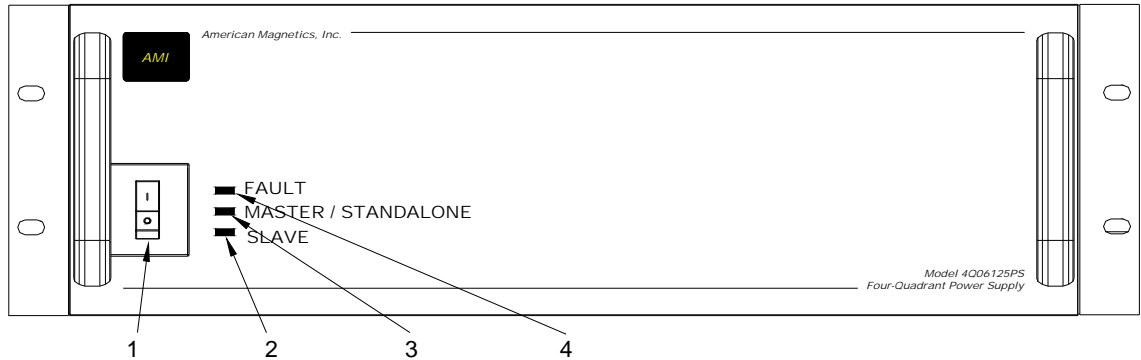

Figure 1-2. Model 4Q06125PS Front Panel

Table 1-3. Power Supply Front Panel Controls and Indicators

Reference (Figure Fig- ure 1-2.)	Control or Indi- cator	Function
1	POWER ON/OFF circuit breaker switch	Applies source power to unit
2	SLAVE indicator	Lights when set as SLAVE Model 4Q06125PS in the 4Q12125PS configuration.
3	MASTER indicator	Lights when configured as MASTER Model 4Q06125PS in the 4Q12125PS configuration
4	FAULT indicator	Lights red when a fault is detected. The following failure or fault conditions can cause the FAULT indicator to light: overtemperature, instant internal overcurrent, output overvoltage/overcurrent, local 15V failure, input under/ overvoltage, input overcurrent, internal output under/ overvoltage, internal output overcurrent, overtempera- ture, fan failure. When the FAULT indicator lights, an audible beep sounds a warning for approximately two seconds and the output is crowbarred by an internal contactor. The fault is latched. After the cause of the fault is removed, the unit can be restarted by cycling the POWER circuit breaker to OFF, then ON, or by applying a START_EXT pulse at Analog I/O Port pin 7

Introduction

Power Supply Front Panel Layout

1.5 System Specifications @ 25°C

Magnet Current Control

Range:	-125 to +125 A
Programming Accuracy:	6.3 mA
Stability:	1.25 mA after 10 min. at desired current
Minimum Ramp Rate:	100 μ A/min
Maximum Ramp Rate:	10 A/sec

Output Voltage

Range:	-12 to +12 Vdc
Measurement Resolution:	10 mV

Load Inductance

Range:	0.5 to 100 H
--------	--------------

Primary Power Requirements

Range:	200 - 230 Vac \pm 10% 50 / 60 Hz, 3800 VA
--------	--

Physical

Dimensions ^a :	19.5" H x 21"W x 24.5" D (495 mm H x 533 mm W x 622 mm D)
Approximate Weight:	200 lbm (90 kg)
Terminal Torque Limit:	48 lbf-in (5.4 N-m)

Environmental Limits

Ambient Temperature:	0 °C to 40 °C (32 °F to 104 °F)
Relative Humidity:	0 to 95%; non-condensing

a. H = height; W = width; D = depth

1.6 Operating Characteristics

The Model 430 Programmer has been designed to perform with various power supplies to allow the user the greatest degree of system flexibility. The power supply and Programmer combination are categorized by one of three forms: *single-quadrant*, *dual-quadrant*, and *four-quadrant*. For sake of clarity, the term *quadrant* is defined as one of four areas of a cartesian coordinate system where the abscissa is current and the ordinate is voltage. Refer to Figure 1-3.

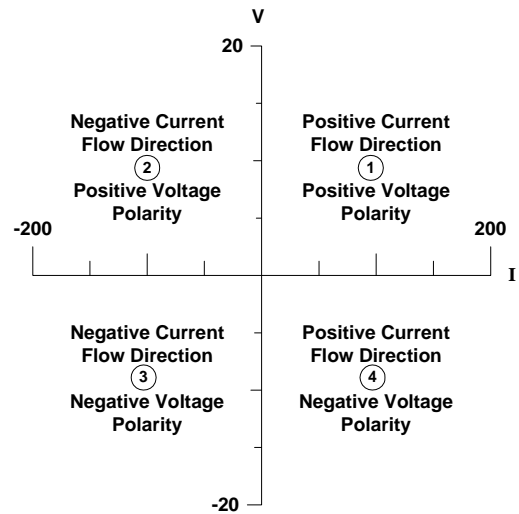

Figure 1-3. The Four Regions, or Quadrants, of System Operation.

1.6.1 Four-Quadrant Operation

The four-quadrant magnet power supply system illustrated in Figure 1-4 offers the most control of all the modes of operation. Efficiency is increased and reversible magnetic field profiles are attainable without discontinuities in the current. All of the voltage and current control is performed electronically so that system reliability is improved. Disadvantages of the four-quadrant system include somewhat increased cost of the power supply over single or dual-quadrant power supplies, and added complexity in protecting the power supply in the event of AC power loss or magnet quenching. Nonetheless, modern four-quadrant power supplies which include integral output protection against AC power loss and magnet quenching are available at reasonable prices.

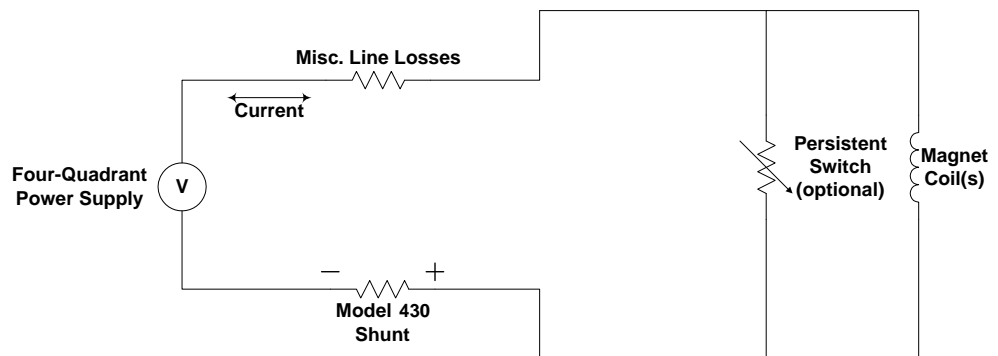

Figure 1-4. Four-Quadrant System with Resistive Shunt

Introduction

Operating Characteristics

The high-stability four-quadrant precision current transducer-based configuration, depicted in Figure 1-5, typically increases the system stability by an order of magnitude.

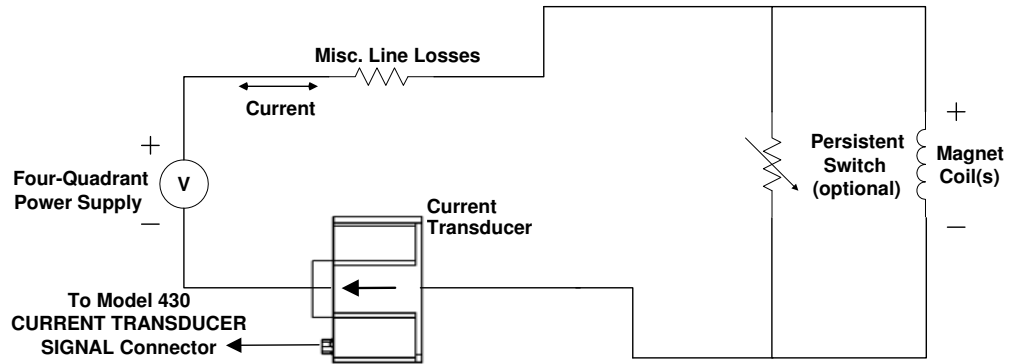

Figure 1-5. Four-Quadrant System with Precision Current Transducer Option

2 Installation

Warning

Before energizing the equipment, the earth ground of the power receptacle must be verified to be at earth potential and able to carry the rated current of the power circuit. Using extension cords should be avoided; however, if one must be used, ensure the ground conductor is intact and capable of carrying the rated current.

In the event that the ground path becomes less than sufficient to carry the rated current of the power circuit, the equipment should be disconnected from power, labeled as unsafe, and removed from place of operation.

Do not operate this equipment in the presence of flammable gases. Doing so could result in a life-threatening explosion.

Do not modify this equipment in any way. If component replacement is required, return the equipment to AMI facilities as described in the Troubleshooting section of this manual.

If used in a manner not specified in this manual, the protection provided by the design, manufacture and documentation of the system may be impaired.

2.1 Inspecting and Unpacking

Carefully remove the equipment, interconnecting cabling, and documentation CD (and/or printed material) from the shipping carton, and remove all packaging material.

Note

If there is any shipping damage, save all packing material and contact the shipping representative to file a damage claim. Do not return to AMI unless prior authorization has been received.

2.2 Power Supply System Mounting

If the system is to be used on a table top, place the equipment on a flat, secure surface.

Installation

Power Requirements

2.3 Power Requirements

Warning

The power requirement for each system component is marked on the rear panel of the unit adjacent to the power entry connectors. Be sure the power supply system is configured for the proper power source prior to plugging in the line cords. Do not fail to connect the input ground terminal securely to an external earth ground.

Ensure the front panel power switches are in the OFF (O) position. Verify that the power supply components are configured for the proper operating voltage by referring to the equipment rear panels. If the operating voltage is correct, plug the line cords into power entry connectors, and into the appropriate power receptacles.

2.3.1 Changing the Model 430 Programmer Operating Voltage

Warning

The following procedure is to be performed only when the Model 430 Programmer is completely de-energized by removing the power-cord from the power receptacle. Failure to do so could result in personnel coming in contact with high voltages capable of producing life-threatening electrical shock.

Note

The voltage selector switch is labeled “115” for nominal line voltages from 100 to 115 VAC. The switch is labeled “230” for nominal line voltages of 200 to 230 VAC.

If the Model 430 Programmer operating voltage must be changed, ensure the instrument is de-energized by disconnecting the power cord from the power source. Remove the Model 430 Programmer cover by removing the four screws on both sides of the cover and the four screws from the corners of the cover on the back panel; slide the voltage selector switch on the main printed circuit board to the proper voltage. Replace the Model 430 Programmer cover.

2.4 Collecting Necessary Information

In order to properly configure the Model 430 Programmer, specific system information is required. Such parameters as the magnet electrical properties, type of power supply, persistent switch heating current requirements, and voltage and current constraints of the magnet are entered into the Model 430 Programmer once and nonvolatile memory will retain the data even after power is removed from the instrument. An

Installation

High-Current Four-Quadrant Supply

example of the data to be entered and how it is entered is described in section 3.11 on page 72.

If the Model 430 Programmer was purchased as part of a magnet system, essential data will have already been entered at the AMI factory and a configuration sheet will have been provided detailing the settings.

2.5 System Interconnects

If the Model 430 Programmer was purchased as part of a magnet system, all applicable system components and wiring harnesses will have been shipped with the system.

Multiple power supplies should be connected to the same AC input power source. The protection is configured so that a fault will shut down all the interconnected power supplies.

The diagrams that follow will assist in system equipment setup.

Caution

The wiring between the power supply and the magnet current leads must be of sufficient size to carry the full rated current of the power supply. Typically, for short runs (less than 25 ft, or 7.6 m), 2 AWG wire is sufficient for 125 A current, and 2/0 AWG wire is best for 250 A current.

Note that an AMI Model 13x Liquid Helium Level Instrument is shown as a possible component of each integrated system. The main instrumentation cable connecting the magnet support stand to one of the Model 430 Programmer **MAGNET STATION** connectors contains all the instrumentation and control connections needed to control and monitor the magnet. The signals in this cable which are required to monitor LHe level and temperatures are also presented at the LHe Level / Temp Connectors. Refer to the *Appendix* for pin-outs of these and other connectors.

2.5.1 High-Current, High-Stability 4-Quadrant Supply

Current stability of the system can be increased by an order of magnitude through application of the zero flux method of current sensing. For the four-quadrant high-current High-Stability Model 4Q12125PS-430 Power Supply System, the components include the zero flux current sensing system, a Model 430 Programmer, two Model 4Q06125PS four-quadrant power supplies, and associated interconnection cabling. Figure 2-1 illustrates the interconnects for a High-Stability Model 4Q12125PS-430 Power Supply.

Installation

High-Current Four-Quadrant Supply

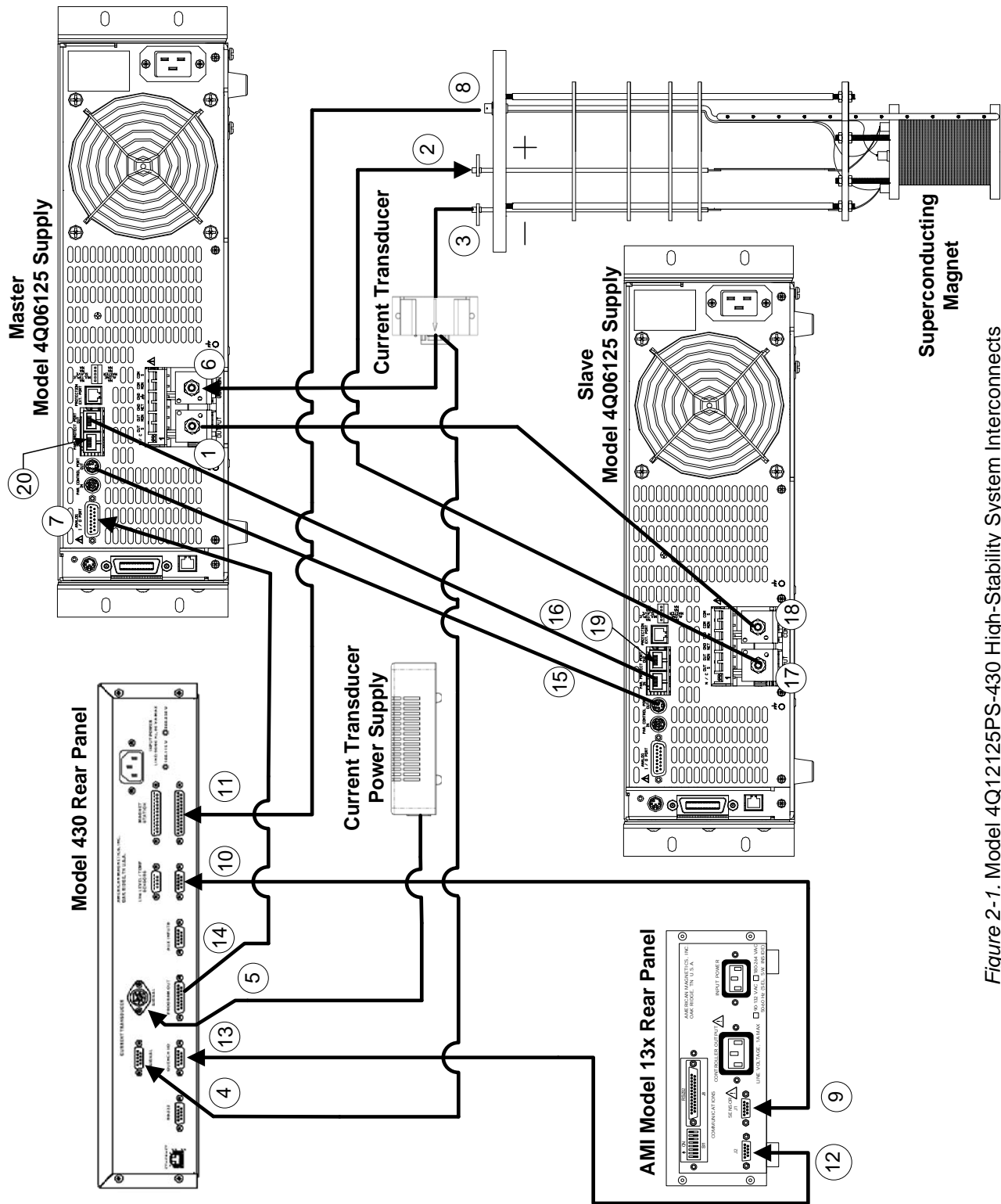

Figure 2-1. Model 4Q12125PS-430 High-Stability System Interconnects

Installation

High-Current Four-Quadrant Supply

Refer to Figure 2-1 on page 14. Ensure the cabling is connected in the following manner:

Note

The use of locking hardware is recommended for all high-current connections.

Caution

Do not overtighten the hardware on the interconnections (refer to specifications table on page 8 for torque limits). Overtightening can result in damage to the terminals.

Note

The current-direction arrow on the CT must point toward the power supply end of the cable.

- a. Connect appropriate load cable to the Master power supply **COMMON** terminal (6) and route it through the zero flux current transducer (see note). Connect the other end to the negative magnet current lead (3).
- b. Connect the positive magnet current lead (2) to the Slave power supply **OUTPUT** terminal (17).
- c. Connect the Master power supply **OUTPUT** terminal (1) to the Slave power supply **COMMON** terminal (18).
- d. Connect the CT power supply to the **TRANSDUCER POWER** connector (5) on the rear of the Model 430 Programmer.
- e. Connect the current transducer output to the current transducer **SIGNAL** connector (4) on the rear of the Model 430 Programmer.
- f. Install the Control Cable (15) and Protective Cable (16) between the two power supplies¹ and install the Protective Terminators (19) and (20).
- g. Connect the DB15 cable from the **PROGRAM OUT** connector (14) on the back of the Model 430 Programmer to the **ANALOG I/O** connector (7) on the rear of the Master power supply.
- h. Install an instrumentation cable between the magnet support stand top plate connector (8) and one of the **MAGNET STATION** connectors (11) on the rear of the Model 430 Programmer.

1. Note the "shifted" connections.

Installation

Magnets w/o Persistent Switch

- i. Optional: Install an instrumentation cable between one of the **LHe / TEMP** connectors (10) on the rear of the Model 430 Programmer and the Model 13x Liquid Helium Level Instrument and/or temperature instrument (9). Refer to section A.6.2 on page 151.
- j. Optional: Install an instrumentation cable between the **QUENCH I/O** connector (13) on the rear of the Model 430 Programmer and Aux connector **J2** on the rear panel of the Model 13x Liquid Helium Level Instrument (12). Refer to section A.6.2 on page 151.
- k. Connect each device line cord from the respective device to the appropriate power receptacle.
- l. Remote communications via Ethernet and/or RS-232 can be accomplished by connecting suitable cabling to the Model 430 Programmer rear panel **ETHERNET** and/or **RS-232** connectors.

2.6 Special Configurations

The Model 430 Programmer has been designed for optimal operation with a superconducting magnet (i.e. a very low resistance, high inductance load) with a persistent switch. The Model 430 Programmer is capable of controlling current to other loads; however, some modification to the Model 430 Programmer settings and/or connections must usually be made. Two commonly encountered configurations are: 1) superconducting magnets without a persistent switch, and 2) operation on a short-circuit or low resistance load.

2.7 Superconducting Magnets with No Persistent Switch

An external stabilizing resistor for superconducting magnets without a persistent switch *is no longer required*¹. However, these systems do require a specific Model 430 Programmer stability setting based on the magnet inductance as follows:

For magnet inductance \leq 100 Henries (H):
Stability Setting = (100 - H)

For magnet inductance $>$ 100 Henries:
Stability Setting = 0

1. Effective with Model 430 firmware version 1.62.

Installation

Operation on a Short-Circuit

2.8 Short-Circuit or Resistive Load

If operating with a short-circuit as a load *without the presence of a superconducting magnet*, the Model 430 Programmer must be manually configured for stability. Normally, when the persistent switch heater is deactivated, the Model 430 Programmer sees essentially a short-circuit load since the persistent switch shunts all current flow away from any connected magnet. Therefore, one method of operating a short-circuit is to indicate that a persistent switch is present, with the persistent switch heater deactivated.

The preferred method is to indicate that a persistent switch is *not* present (see section 3.10.2.6 on page 54) and adjust the stability setting (see section 3.10.2.1 on page 48) to control the load. *A stability setting of 100% will always allow control of a short-circuit as the load*, regardless of the state of the persistent switch heater.

If the resistance of the load is *increased*, the stability setting must be *decreased* to improve the transient response of the system. If the current appears to lag, then decrease the stability setting until the system is responsive. If the current appears to oscillate, increase the stability setting until the oscillations are damped.

Note

If you have purchased a superconducting magnet with the Model 430 Programmer, AMI will normally provide a recommended stability setting for optimal operation of the magnet system. If you operate the Model 430 Programmer with a different load, be sure to restore the stability setting to the recommended value when the superconducting magnet is reconnected.

The stability setting is essentially manual control of the gain of an integrator present in the control logic of the Model 430 Programmer. Increasing the stability setting decreases the gain of the integrator.

2.9 Power-Up and Test Procedure

It is important to verify that the magnet system has been properly connected before the superconducting magnet is energized. This is especially recommended if the system is to be controlled via a computer since this setup will allow software debugging without the potential for damage to the magnet. The following procedures will assist the user in the verifying key system components.

1. Using the appropriate diagram from section 2.5 as a guide, verify all system components are connected as shown. If there is any

Installation

Power-Up Procedure

doubt as to the correct connection of a component, contact an AMI Technical Support Representative. The user may be required to properly make a few connections between the various system components which were disconnected to facilitate packing and shipping.

2. Temporarily place a short across the magnet current terminals. Often this is most easily accomplished by unfastening the heavy cables from the magnet current leads and fastening them together.¹ This will allow rudimentary power supply checks without energizing the superconducting magnet.
3. Energize the Model 430 Programmer by placing the power switch in the I (ON) position.
4. When prompted by the Model 430 Programmer, energize the power supply and press ENTER on the Model 430 Programmer.

Note

The slave unit must be turned on between 2 to 5 seconds after the master, otherwise the units will fault and the power-up for both units will have to be repeated.

Warning



All power supply parameters, both hardware and software, have been set at the AMI factory. Power supply control, with the exception of powering ON and OFF sequencing, is done by way of the AMI Model 430 Power Supply Programmer. No field adjustments or reconfiguration of the power supply should be attempted in the field unless specifically described in this document or recommended in writing by an AMI Technical Support Representative.

5. Enter a stability setting of 100%. Refer to sections 3.3 on page 25 and 3.7.9 on page 39.
6. Verify the various setup menu values for the system (with the exception of the stability setting, which is to be temporarily left at 100%). If the power supply system was purchased with an AMI magnet, AMI has preset the setup menu values for proper operation. See sections 3.3, 3.5, 3.9 and 3.10 for more discussion of the setup menu values and their entry into the Model 430 Programmer.

1. If the system shipped with CamLoc quick-disconnect connectors, they may be quickly disconnected from the magnet leads and connected together.

Installation

Power-Up Procedure

7. Set the Model 430 Programmer to display current (rather than field). Refer to sections 3.2.1 and 3.7.5.
8. Set the ramp rate to 1 A/sec. Refer to sections 3.3 on page 25 and 3.7.1 on page 33.
9. Set the target current to 10 A. Refer to sections 3.3 on page 25 and 3.6.2 on page 31.
10. If a Persistent Switch is installed, set the PSw P/S Ramp Rate to 10 A/sec. Refer to paragraph 3.10.2.11 on page 56
11. Initiate ramping to the target current by pressing the **RAMP / PAUSE** key (status indicator changes from  to ).
12. The system should ramp to 10 A in approximately 10 seconds. Verify this is the case (if a PSwitch is installed and in the cooled state, ramp time to 10 A should be slightly less than 2 seconds).
13. When the target current is achieved, the **FIELD AT TARGET LED** will be illuminated. The display should show “+10.00 A -” indicating that the Model 430 Programmer is in the holding mode at the target current value (+10.00 A).

Note

There may be a discrepancy between the current shown on the power supply display¹ and the current displayed on the Model 430 Programmer. The current measurement system incorporated in the Model 430 is more accurate than the power supply shunt.

14. Verify that the output current display of the power supply indicates that it is supplying 10 A to the load (which is only the cabling in this case).
15. Set the target current to the master current limit value. Refer to section 3.10.2.4 on page 52 to determine the master current limit value. After the new target current value is entered, the Model 430 Programmer should ramp automatically to the new setting.
16. When the new target current value is reached, the power supply current display (if provided) should also indicate the new value.
17. Press the **RAMP TO ZERO** key to ramp the system to zero current.
18. Perform remote control software checkout as required.

1. Not all power supplies have a local current readout.

Installation

Power-Up Procedure

19. Turn off the power supply.
20. Reset the stability setting and ramp rate of the Model 430 Programmer to an appropriate value for the magnet to be operated. Then turn off the Model 430.
21. Remove the short from the power supply leads and connect the leads to the magnet current leads of the magnet.

After successful completion of this test, the system is ready for operation with a superconducting magnet. Refer to the ramping function example presented in section 3.14 on page 85 for a discussion of the various available ramping methods.

3 Operation

This section describes the operation of the Model 430 Programmer. Every menu and submenu item is illustrated and described in detail. An example setup of the Model 430 Programmer is presented in section 3.11 on page 72. An example ramping operation is presented in section 3.14 on page 85.

3.1 System Power On/Off Sequence

The Model 430 Programmer should always be energized *before* the power supply that it is controlling. The Model 430 Programmer is designed to prompt the user in order to ensure the power supply is energized at the proper time. The Model 430 Programmer should always be de-energized *after* the power supply is shut down.

3.1.1 Model 430 Programmer Power On/Off

Place the Model 430 Programmer power switch in the ON position. After the Model 430 Programmer is powered on and fully initialized (about 20 seconds), the following display will appear:

```
+0.00 A - Turn on power supply
+0.00 Vs Press ENTER to continue
```

After this screen is displayed, the power supply can be powered up (See “Energizing Power Supply and Components” on page 22.) *followed by* pressing the **ENTER** key on the Model 430 Programmer. This brings up the default display¹.

Note

If turned off, the Model 430 Programmer must remain unpowered for at least 5 seconds before it is powered back on. If not, there may be an initialization error, in which case the following screen will be displayed.

```
AMI Model 430 Programmer
FAILURE TO LOAD.
```

1. Refer to section 3.2 on page 23.

Operation

Energizing Power Supply System Components

If this occurs, turn the Model 430 Programmer off, wait 15 seconds or more, and power the Model 430 Programmer back on.

When powering the system off, first turn off the power supply controlled by the Model 430 Programmer followed by the Model 430 Programmer. The controller will then ensure the load sees no abnormal power transients as the power supply is turning off.

3.1.2 Energizing Power Supply and Components

Warning

Do not change power supply jumpers, dip-switches, or other factory settings. If not rack-mounted, always position power supplies for convenience in disconnecting the power cords.

Caution

The master unit must be turned on between 2 to 5 seconds before the slave, otherwise the units will fault and the power-up sequence will have to be repeated.

Place the power supply switches in the ON position in sequence (see Caution Note). No local (front panel) adjustments or connections are required since the power supply control mode and other parameters have been factory-configured for control by the AMI Model 430 Power Supply Programmer.

When powering the system off, turn OFF the power supplies (master unit *last*) before powering off the Model 430 Programmer.

3.1.2.1 Zero Flux Current Transducer Power Supply

Caution

Operating the system without power applied to the current transformer (CT) can will result in loss of control, and will probably damage the CT.

The current transducer power supply is operational immediately upon connection to a power receptacle. The supply must be connected to the Model 430 rear panel *POWER* connector. The current transducer receives this power indirectly via the *SIGNAL* connection to the rear panel of the Model 430 Programmer.

Operation

Default Display

3.2 Model 430 Programmer Default Display

The default display is illustrated in the figure below. It is displayed whenever no menus are being accessed and no errors are being indicated. The default display can be thought of as being logically divided into four display areas — the Field / Current Display area, the Voltage Display area, the Status Indicator area and the Main Display area.

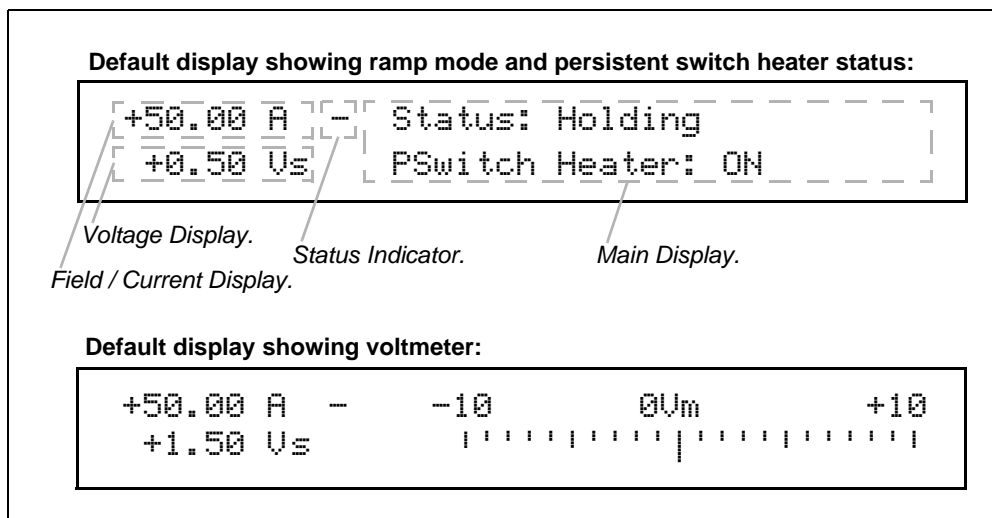

Figure 3-1. Default Display.

3.2.1 Field / Current Display

The field / current display indicates either the field strength or current¹. This is always displayed in the upper left corner of the display (see Figure 3-1), regardless of what else is being displayed on the Model 430 Programmer display. The parameter displayed (field or current) is toggled by pressing **SHIFT** followed by **FIELD <> CURRENT**. Thus, if field strength is being displayed, pressing **SHIFT** followed by **FIELD <> CURRENT** will cause the current to be displayed; conversely, if current is being displayed, pressing **SHIFT** followed by **FIELD <> CURRENT** will cause the field strength to be displayed. Operating current is always displayed in amperes (A). Operating field strength may be displayed in kilogauss (kG) or tesla (T) if a coil constant has been specified in the setup². If field strength is being displayed, the units (kG or T) in which it is displayed can be toggled by pressing **SHIFT** followed by **FIELD UNITS**.

-
1. The value is always displayed in current (A) when an installed persistent switch is in the *cooled state* since the value represents power supply current only, independent of magnet current/field.
 2. Refer to section 3.10.2.2 on page 50.

Operation

Default Display : Voltage

Note

Note that the displayed field strength is not directly measured, but rather is calculated by multiplying the coil constant entered in the setup menu by the measured current flow of the Model 430 power supply system.

3.2.2 Voltage Display







The voltage display indicates either the voltage across the magnet (V_m) or the power supply output voltage (V_s). This is always displayed in the lower left corner of the display (see Figure 3-1), regardless of what else is being displayed on the Model 430 Programmer display. The parameter displayed (magnet voltage or power supply voltage) is toggled by pressing **SHIFT** followed by **Vs <> Vm**. V_m indicates the voltage measured across the terminals of the connected superconducting magnet. In order for the Model 430 Programmer to measure the magnet voltage, the magnet voltage taps must be connected to the Model 430. Normally this is done through the Magnet Station Cable provided by AMI (if the whole magnet system is provided by AMI). V_s indicates the Model 430 Programmer-controlled power supply output voltage.

Note

Note that the displayed power supply voltage (V_s) is not directly measured, but rather is calculated based on power supply control voltage being provided by the Model 430 Programmer and the power supply input control voltage and output voltage values entered in the setup menu.

3.2.3 Status Indicator

Table 3-1. Description of Status Indicators

	Paused
	Ramping Up
	Ramping Down
	Holding
	Heating Persistent Switch
	Cooling Persistent Switch
	Voltage Limit

The status indicator indicates the Model 430 Programmer operating status. It is always visible (except during a quench condition) and is displayed just to the right of the field / current display (see Figure 3-1). The status indicator may be one of six symbols indicating one of the seven states shown in Table 3-1.

If the ramping mode character is blank, then a quench condition exists and the red **MAGNET QUENCH** indicator in the status section of the front panel will be

illuminated. See section 3.12 on page 74 for a detailed discussion of the

Operation

Default Display : Main

meaning of the ramping modes (Paused, Ramping Up, Ramping Down and Holding).

3.2.4 Main Display

The default main display (the rightmost portion of the display – see Figure 3-1) shows either a voltmeter indicating magnet voltage or ramp mode and persistent switch heater state. Ramp mode is displayed on the top line of the main display; it will be one of eight states, as shown in Table 3-6 on page 76. Persistent switch heater state is displayed on the bottom line of the main display. If the Model 430 Programmer has been setup for use with a persistent switch, it will indicate either ON or OFF for the persistent switch heater state; otherwise, it will display “No PSwitch Installed.”

3.3 Entering Numeric Values

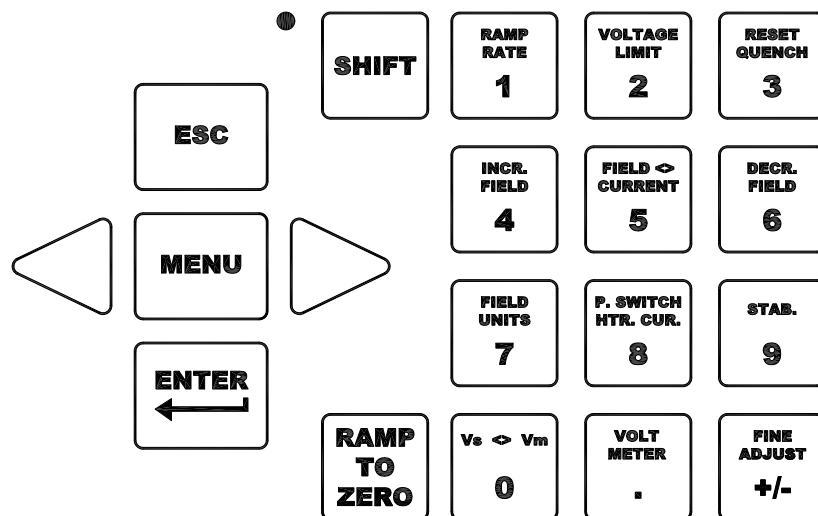

Figure 3-2. Numeric Keypad and Associated Keys

A consistent method of entering values is used within menus requiring numeric entries. Once a menu is selected, the user may start an entry by pressing a digit (0 through 9), the decimal key (.), or the sign key (+/-).¹ The display will begin a new entry and display a cursor () as a prompt for the next digit or decimal entry. Also, once entry is initiated, the display will show an asterisk (*) indicating that numeric entry is *active*. Alternately, the ENTER key may be pressed before any of the numeric keypad keys; the display will begin a new entry and display a cursor () as a prompt for the next digit or decimal entry, and the display will show an

1. Certain menu items requiring numeric data can also be entered using the fine adjust knob (see section 3.4 on page 26).

Operation

Fine Adjust Knob Operation

asterisk (*) indicating that numeric entry is *active*. An example of a numeric entry in progress (numeric entry active) is illustrated below:

```
+50.00 A - Target Current (A)*  
+0.50 Vs +74_
```

Once the numeric value has been entered, press the **ENTER** key to accept the numeric value. Values are *not* applied to the operation of the Model 430 Programmer until the **ENTER** key is pressed and the asterisk disappears from the display. Attempts to set a parameter to a value outside of the valid range are ignored, and if attempted the Model 430 Programmer will beep once indicating an error and revert to the previous setting.

If the **ESC** key is pressed while numeric entry is active and digits have been entered, the entered digits will be cleared and the cursor will remain for reentry of a new desired value. If the **ESC** key is pressed with *no* entered digits on the display, the setting will revert to the previous value and numeric entry will be made inactive. Thus, if digits have been entered, the first time **ESC** is pressed, the entered digits are cleared, but numeric entry remains active; if **ESC** is then pressed again (with no entered digits displayed), the setting reverts to its previous value and numeric entry is made inactive. Note that if the **ESC** key is pressed when numeric entry is *not* active, the current submenu will be exited and the next higher level submenu will be entered.

3.4 Using Fine Adjust Knob to Adjust Numeric Values

For menu items requiring entry of a numeric value, the value may alternatively be adjusted with the front panel fine adjust knob. These menu items include:

- Target Field Setpoint (in holding mode or while ramping)
- Voltage Limit
- Ramp Rate (if there is no PSwitch or if PSwitch is fully heated). Disallowed during switch heating/cooling transition.
- Custom Supply Menu (Min Output Voltage, Max Output Voltage, Min Output Current, Max Output Current)
- Stability
- Coil Constant
- Current Limit
- Magnet Current Rating

Operation

Entering Picklist Values

- P_{Sw} P/S Ramp Rate if P_{Switch} is fully cooled. Disallowed during switch heating/cooling transition.
- P_{Switch} Current
- P_{Switch} Heated Time
- P_{Switch} Cooled Time
- P_{Switch} Cooling Gain
- Quench Rate

Instead of entering a value using the numeric keypad, **SHIFT** is pressed, followed by **FINE ADJUST**. The display will show an up/down arrow (↕) indicating that the fine adjust knob is active.

When the fine adjust knob is live, adjustments made using it take place *immediately*. This is a very useful and powerful functionality. Any numeric value can be incrementally adjusted using the fine adjust knob, and its affect on the system can be observed *as the adjustment is being made*. For example, with the persistent switch heater on, the persistent switch heater current can be adjusted incrementally to find the persistent switch heater superconducting/normal thresholds. An example of a fine adjust in progress (fine adjust knob is live) is illustrated below:

```
+50.00 A - PSwitch Current (mA)↕  
+0.50 Us      46.7
```

Note

The fine adjust knob is velocity-sensitive, meaning that the faster the knob is turned, the more coarse the adjustment. Slow manipulation of the knob will yield very fine resolution even beyond that displayed by the Model 430 Programmer.

When the desired numeric value has been set using the fine adjust knob, the **ENTER** key is pressed to store the value. Pressing the **ESC** key while the fine adjust knob is live will cause the adjusted value to revert to its previous setting and make the fine adjust knob inactive. In fact, pressing *any* key other than **ENTER** will cause the adjusted value to revert to its previous setting and make the fine adjust knob inactive.

3.5 Entering Picklist Values

Some submenu items require the user to select a value from a list of predefined values (picklist values). Such menus will display an item selector (▶) which points to the picklist value currently selected. To change the value to another value in the picklist, first press the **ENTER**

Operation

Single-key Commands

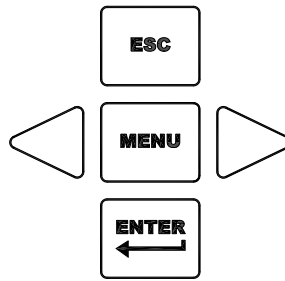

Figure 3-3. Menu Navigation Keys

key; the display will show an asterisk (*) indicating that picklist entry is *active*.

While picklist entry is active, the left and right *keypad* arrows (to the left and right of the **MENU** key) move the item selector between the different picklist values. Pressing the left keypad arrow moves the item selector one picklist value to the left and pressing the right keypad arrow moves the item selector one picklist value to the right. When the last picklist value is reached, and the right keypad arrow is pressed, the item selector will move to the first picklist value. Likewise, when the item selector is pointing to the first picklist value, and the left keypad arrow is pressed, the item selector will move to the last picklist value. An example of a picklist entry in progress (picklist entry active) is illustrated below:

```
+50.00 A - Field Units*
+0.50 Us  ▶ Kilogauss Tesla
```

When the item selector is pointing at the desired picklist value, press the **ENTER** key to accept the picklist value. Values are *not* applied to the operation of the Model 430 Programmer until the **ENTER** key is pressed and the asterisk disappears from the display.

If the **ESC** key is pressed while picklist entry is active, the setting will revert to the previous value and picklist entry will be made inactive. Note that if the **ESC** key is pressed when numeric entry is *not* active, the current submenu will be exited and the next higher level submenu will be entered (if it exists).

3.6 Single-key Commands / Menu

All ramping controls (**PERSIST. SWITCH CONTROL**, **TARGET FIELD SETPOINT**, **RAMP / PAUSE** and **RAMP TO ZERO**) are accessed with a single keystroke. See section 3.12 on page 74 for details of ramping controls. Below is a brief summary of the function of each of these keys.

Operation

Single-key Commands : Persistent Switch Control

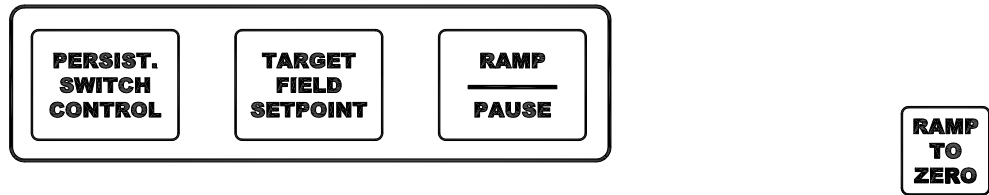

Figure 3-4. Single Input Keys

3.6.1 Persistent Switch Control Key

Pressing the **PERSIST. SWITCH CONTROL** key toggles the Model 430 Programmer persistent switch heater control function.

If the persistent switch heater is energized and this key is pressed, the persistent switch heater is de-energized. The power supply is then maintained for the time set by the PSwitch Cooled Time variable before being ramped down to zero at the rate set by the PSw P/S Ramp Rate variable (default rate is 10 A/sec).

If the persistent switch heater is de-energized and this key is pressed, the power supply is ramped to the current present in the magnet when the switch was cooled at the rate set by the PSw P/S Ramp Rate variable and then the persistent switch heater is energized.

Pressing **SHIFT** followed by the **PERSIST. SWITCH CONTROL** key toggles the Model 430 Programmer persistent switch heater between energized (turned on) and de-energized (turned off). If the persistent switch heater is energized and this key is pressed, the persistent switch heater is de-energized. If the persistent switch heater is de-energized and this key is pressed, the persistent switch heater is energized.

Note

*The power supply current is unchanged when **SHIFT + PERSIST. SWITCH CONTROL** is used. Only the state of the persistent switch heater is changed.*

When the persistent switch heater is energized, the Model 430 Programmer is supplying current to the appropriate pins (9 & 10) of the Magnet Station Connectors in order to drive the persistent switch into a normal state, which takes the magnet out of persistent mode. Magnet persistent mode is indicated by the **MAGNET IN PERSISTENT MODE LED**¹.

The Model 430 Programmer will beep once (indicating an error) if the user attempts to activate the switch heater control without first indicating a

1. Refer to section 3.8.2.2 on page 40.

Operation

Single-key Commands : Persistent Switch Control

persistent switch is installed in the Load submenu and specifying the switch heating current, heated time, and cooled time¹.

The nominal switch heating current is listed on the magnet specification sheet, and may be entered in the Model 430 Programmer by accessing the Load submenu². In addition to the *heating current*, the user must also specify a *heated time*, *cooled time*, *PSw P/S Ramp Rate* and *cooling gain*. The heated time allows the Model 430 Programmer to delay compensating the internal control logic until the magnet is guaranteed to be in the circuit. The heated time can be set from a minimum of 5 seconds to a maximum of 120 seconds within the Load submenu³. The default heating period of 20 seconds is adequate for the majority of persistent switches.

If the magnet appears unstable just after the switch heating period expires, increase the switch heated time to allow for complete heating. The cooled time allows the persistent switch sufficient time to be cooled to superconducting state before the current is changed in the magnet. The cooled time can be set from a minimum of 5 seconds to a maximum of 3600 seconds within the Load submenu⁴. The default cooling period of 20 seconds is adequate for the majority of wet persistent switches. Conduction cooled switches typically require longer time to transition from resistive to superconducting.

The default cooling gain of 0.0% may be adequate for the majority of wet persistent switches. However, this setting may result in some magnet drift during persistent switch cooling, especially with conduction cooled switches. Increasing the cooling gain adds control loop gain during the switch cooling cycle. Too little may result in magnet drift during switch cooling. Too much may result in power supply instability during switch cooling, which could potentially prevent the switch from cooling. Most systems requiring some cooling gain to control magnet drift will likely work with value set to 25%.

Note

During the period the switch is being heated or cooled, the Model 430 Programmer will not allow ramping functions to be executed and will beep once if the user attempts to initiate a ramping operation.

Refer to section 3.13 on page 77 for a complete description of magnet persistent switch control. A flowchart of the persistent switch control functions are located in the Appendix beginning on page 190.

-
1. Refer to section 3.10.2.6 on page 54, section 3.10.2.8 on page 55, section 3.10.2.9 on page 55, and section 3.10.2.10 on page 56.
 2. Refer to section 3.10.2.8 on page 55.
 3. Refer to section 3.10.2.9 on page 55.
 4. Refer to section 3.10.2.10 on page 56.

Operation

Single-key Commands : Target Field Setpoint

3.6.2 Target Field Setpoint Key

```
+50.00 A - Target Field (kG)
+0.50 Vs +50.000
```

Pressing the **TARGET FIELD SETPOINT** key provides a menu for setting the target field/current. The target field/current is the field or current to which the Model 430 Programmer ramps the superconducting magnet when it is not paused. The target field/current may be set to the lesser of (1) the Magnet Current Rating, and (2) the Current Limit¹ or equivalent field (per defined coil constant). The target field/current requires a sign since it defines a setpoint within the entire field/current range of the system (positive or negative).

When on the default display, pressing the **SHIFT + TARGET FIELD SETPOINT** keys will temporarily display the Magnet Current/Field for three seconds before reverting to the default display. The value displayed is as follows:

- When in driven mode, the present current/field will be displayed.
- When in persistent mode, the current/field will be displayed that was flowing in the magnet at the time persistent switch was cooled.

```
+0.25 A P Magnet Current (A)
+0.00 Vs +10.00 A
```

3.6.3 Ramp / Pause Key

Pressing the **RAMP / PAUSE** key toggles the Model 430 Programmer between the ramping mode and the paused mode. If the **RAMP / PAUSE** key is pressed while the Model 430 is ramping, the ramping is paused. If the **RAMP / PAUSE** key is pressed while the Model 430 is paused, the Model 430 continues ramping.

3.6.4 Ramp To Zero Key

Pressing the **RAMP TO ZERO** key causes the Model 430 Programmer to immediately begin ramping field/current up or down to zero field/current at the defined ramp rate(s). Ramping to zero may be interrupted at any time by pressing the **RAMP / PAUSE** key, which causes the Model 430 Programmer to enter the **PAUSED** mode and maintain the field/current present at the point it was paused.

1. Refer to section 3.10.2.4 on page 52.

Operation

Shift Key Commands

Note

If the **RAMP TO ZERO** function is **PAUSED** and then the **RAMP / PAUSE** button is pressed a second time, the Model 430 Programmer will begin ramping to the target field, not to zero. If it is desired to ramp to zero after the **RAMP / PAUSE** button is pressed, press the **RAMP TO ZERO** button again to continue ramping to zero from the paused state.

Note

If the magnet is persistent (persistent switch heater is not energized) when the **RAMP TO ZERO** key is pressed, the Model 430 Programmer ramps the power supply current to zero; the magnet current will remain constant since the magnet is in persistent mode.

3.7 SHIFT-key Commands / Menus

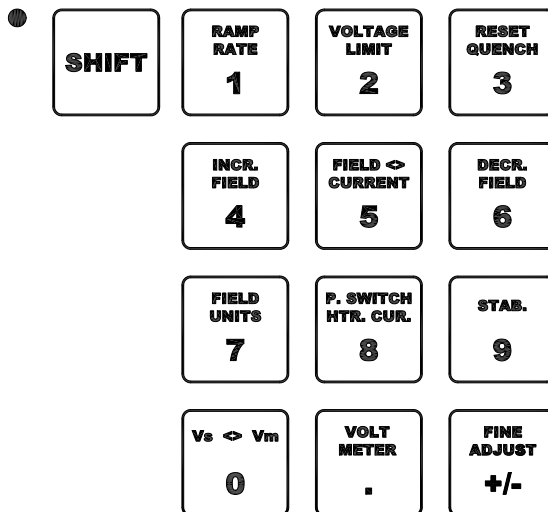

Figure 3-5. SHIFT-Key Functions

The most commonly used commands and menus (other than ramping controls) are accessed using the **SHIFT** key followed by a numeric keypad key. Use of the specific **SHIFT**-key commands and menus is described in sections specific to the functionality of that specific **SHIFT**-key. In general, a **SHIFT**-key command is executed or **SHIFT**-key menu is accessed by first pressing the **SHIFT** key (which turns on the **SHIFT** LED), and then pressing¹ one of the keys of the numeric keypad (**0** through **9**, **.**, or **+/-**). The **SHIFT**-key command / menu for each key of the numeric keypad is shown in light blue text at the top of each key. To access the voltage limit

1. Note the **SHIFT** key and the following keypad key-press are sequential, not simultaneous.

Operation

Shift Key Commands : Ramp Rate

menu, for example, press the **SHIFT** key, and then press the **VOLTAGE LIMIT** key (also the **2** key). Note that some of the **SHIFT**-key menus can also be accessed using the setup menu.

Pressing the **ESC** key or the **SHIFT** key a second time will clear the **SHIFT** function and return the keypad to its numeric function.

3.7.1 Ramp Rate **SHIFT**-key

Use of the **RAMP RATE SHIFT**-key provides a menu for setting ramp rate(s). The ramp rate may be set¹ within the range specified for the specific Model 430 Programmer configuration (refer to specifications on page 8). If field units are being used, then the ramp rate setting is displayed and set in units of kG/sec or T/sec). The allowable range is then defined by the setting of the coil constant and the allowable range of the ramp rate in terms of current as specified in the table on page 8. If the Ramp Segments value² is greater than 1, then the menu also allows setting of the field or current range for which each ramp rate is to be used.

The Model 430 Programmer will ramp at the specified rate if the available compliance of the power supply is sufficient and the Voltage Limit is not exceeded. The Model 430 automatically decreases the ramp rate internally during operation if either the available compliance of the power supply is insufficient, or the Voltage Limit is active.

3.7.1.1 Ramp Rate **SHIFT**-key Example

An example (using a magnet with rated current of 60 A³) will illustrate the use of the ramp rate menus. The example assumes that the field/current units have been set to amperes, and the ramp segments value has been set to 3. Segmented magnet current ramping is chosen with rates as follows:

1. ± 0.2 A/s from 0 to ± 55 A
2. ± 0.1 A/s from ± 55 to ± 58 A
3. ± 0.05 A/s above ± 58 A.

In the following discussion, the fine adjust knob⁴ can optionally be used for ramp rate adjustment if the persistent switch is heated (or if no persistent switch is installed). If the user attempts to edit ramp rate segments using the fine adjust knob while an installed switch is cooled, the Model 430 Programmer will produce one beep to indicate an error⁵. Similarly, if the switch is heated (or no switch

-
1. Using numerical keys per section 3.3 on page 25 or the fine adjust knob (see section 3.4 on page 26).
 2. Refer to section 3.10.3.2 on page 59.
 3. In this example, both the Current Limit and Magnet Current Rating are set at the rated magnet current of 60 A.
 4. Refer to section 3.4 on page 26.

Operation

Shift Key Commands : Ramp Rate

is installed), attempting to use the fine adjust knob for PSw P/S ramp rate will produce one beep¹.

Pressing **SHIFT** and then **RAMP RATE** will access the ramp rate menu. The numeric and **ENTER** keys (or the fine adjust knob) are used to set the segment 1 ramp rate to a value of 0.2.

```
+50.00 A - Seg.1 Ramp Rate (A/sec)
+0.50 Us ±0.2000
```

The right arrow key is pressed once to access the segment 1 range display. The numeric and **ENTER** keys (or fine adjust knob) are used to set the segment 1 current range upper bound to a value of 55.

```
+50.00 A - Seg.1 Range (A)
+0.50 Us 0.0 to ±55.0
```

Pressing the right arrow key accesses the next (second) segment ramp-rate display. The segment 2 ramp rate is set to a value of 0.1.

```
+50.00 A - Seg.2 Ramp Rate (A/sec)
+0.50 Us ±0.1000
```

The right arrow key is pressed once to access the segment 2 range display. The segment 2 current range upper bound is set to a value of 58.

```
+50.00 A - Seg.2 Range (A)
+0.50 Us ±55.0 to ±58.0
```

-
5. Since the PSw P/S ramp rate is active in that scenario, and not the segmented ramp rate.
 1. Since the standard segmented ramp rate is active in that scenario, and not the PSw P/S ramp rate.

Operation

Shift Key Commands : Ramp Rate

Pressing the right arrow key accesses the next (third) segment ramp rate display. The segment 3 ramp rate is set to a value of 0.05.

```
+50.00 A - Seg.3 Ramp Rate (A/sec)
+0.50 Us ±0.0500
```

Pressing the right arrow key accesses the segment 3 current range display.

Note

Note that when there is more than one segment, the upper bound of the last segment is always the Magnet Current Rating¹ (or the Current Limit if set lower than the Magnet Current Rating); it will be displayed as "±Limit" and cannot be edited.

```
+50.00 A - Seg.3 Range (A)
+0.50 Us ±58.0 to ±Limit
```

Now, when current is in the range of 0 to ±55 A, ramping will be controlled at ±0.2 A/s. When current is in the range of ±55 to ±58 A, ramping will be controlled at ±0.1 A/s and when current is greater than ±58 A (up to the limit of 60 A), ramping will be controlled at ±0.05 A/s.

If ramp rate of a ramp segment is being edited while the Model 430 is ramping and the system current/field transitions from the currently edited segment to the next before the adjustment has been committed with the **ENTER** key, the adjusted value *will be discarded*. The display will update to show the new segment ramp rate, and the fine adjust knob will apply to the new segment (assuming the **ENTER** key is pressed before the segment has completed).

If at some later time it is desired to temporarily set the Current Limit to a new value *lower* than the Magnet Current Rating, for example 56 A, this lower value will override the Magnet Current Rating. Now only the first two ramp segments would be active since

1. Refer to section 3.10.2.4 on page 52 and section 3.10.2.3 on page 51.

Operation

Shift Key Commands : Voltage Limit

the new “limit” falls within the range of segment 2. The display for segment 2 range will now appear as follows¹.

```
+50.00 A - Seg.2 Range (A)
+0.50 Us ±55.0 to ±Limit
```

The unused segment(s) will remain in memory (retaining their original parameters) until one or more become active again as the Current Limit is raised into or above the respective ranges. When displayed, the higher-range *unused* segments will show a range of “±Limit to ±Limit” until re-activated².

```
+50.00 A - Seg.3 Range (A)
+0.50 Us ±Limit to ±Limit
```

If the Current Limit is raised *above* the Magnet Current Rating, it will be ignored and the actual Magnet Current Rating will govern.

3.7.2 Voltage Limit SHIFT-key

```
+50.00 A - Voltage Limit (V)
+0.50 Us ±2.000
```

Use of the **VOLTAGE LIMIT SHIFT**-key provides a menu for setting the limit for output voltage for the power supply the Model 430 Programmer controls. This value should be set to a high enough value so that under normal conditions, the Voltage Limit is never reached. The value can be set by using either the numeric keypad per section 3.3 on page 25 or the fine adjust knob (section 3.4 on page 26). Note that the voltage drop in the leads must be accounted for when setting the Voltage Limit, as well as the voltage drop of an energy absorber if one is used (see section 3.12 on page 74 for details of how to determine the appropriate Voltage Limit).

The Voltage Limit may be set less than or equal to the maximum output voltage of the power supply.³ The Voltage Limit does not require a sign since it functions as both the negative and positive limit.

-
1. If the value were to be set below 55 A, only segment 1 would be active, and would display the upper bound of “±Limit”.
 2. Also if the number of segments is increased, the new segments are added to the upper end of the ramp range, and default to the ramp rate of the previous segment with the range of +/-Limit to +/-Limit until set up.
 3. Refer to Table 3-2 on page 45.

Operation

Shift Key Commands : Reset Quench

If Voltage Limit becomes active while ramping, it will be indicated by a reverse illumination character “V” for the status indicator.

```
+40.92 A  ↑  Mode: Ramping
+2.50 Vs  ↓  PSwitch: ON
```

Once the Voltage Limit function becomes active, the current, and therefore field, will no longer be ramping linearly with time as the voltage available to charge the magnet will be reduced as the total loop voltage will be limited. As the IR drop of the leads increased with current, the voltage available to charge the magnet will be reduced.

3.7.3 Reset Quench SHIFT-key

The **RESET QUENCH SHIFT**-key is used whenever a quench detection has occurred and is being indicated on the display (example shown below).

```
+0.00 A  -  Quench Detect @ +45.81 A
+0.00 Vs  PSwitch Heater: ON
```

When a quench detection has occurred, the Model 430 Programmer will respond to no further input until the **RESET QUENCH SHIFT**-key is used, or until the quench condition is cleared by a remote command. See Refer to section 3.15 on page 86.

3.7.4 Increment Field SHIFT-key

The **INCR. FIELD SHIFT**-key is used to manually increase the field. This is done at the defined ramp rate.

When the **INCR. FIELD SHIFT**-key is used, the current/field begins ramping up. If the **INCR. FIELD SHIFT**-key is used again (while the current/field is manually ramping up), the ramping will be paused. Alternately, the **RAMP / PAUSE** key may be pressed to pause manual ramping. Manual ramping will continue until paused or the Current Limit¹ or Magnet Current Rating is achieved.

Note

*If the current/field is negative, using the **INCR. FIELD SHIFT**-key to increase (make more positive) the current/field, the magnitude of the current/field decreases.*

1. Refer to section 3.10.2.4 on page 52.

Operation

Shift Key Commands : Field <> Current

3.7.5 Field <> Current SHIFT-key

The **FIELD <> CURRENT** SHIFT-key is used to toggle between the use of field units, either kG (kilogauss) or T (tesla), and the use of current units (A)¹. If the Model 430 Programmer is using field units (either kG or T) and the **FIELD <> CURRENT** SHIFT-key is used, the Model 430 Programmer will begin using current units (A). Conversely, if the Model 430 is using current units (A) and the **FIELD <> CURRENT** SHIFT-key is used, the Model 430 will begin using field units (either kG or T).

Note

The Model 430 Programmer cannot use field units unless a valid coil constant has been entered².

3.7.6 Decrement Field SHIFT-key

The **DECR. FIELD** SHIFT-key is used to manually decrease the current/field. This is done at the defined ramp rate.

When the **DECR. FIELD** SHIFT-key is used, the current/field begins ramping down. If the **DECR. FIELD** SHIFT-key is used again (while the current/field is manually ramping down), the ramping will be paused. Alternately, the **RAMP / PAUSE** key may be pressed to pause manual ramping. Manual ramping will continue until paused or the Current Limit³ or Magnet Current Rating is achieved.

Note

*If the current/field is negative, using the **DECR. FIELD** SHIFT-key to decrease (make less positive) the current/field, the magnitude of the current/field increases.*

3.7.7 Field Units SHIFT-key

```
+50.00 A - Field Units
+0.50 Vs ▶ Kilogauss Tesla
```

Use of the **FIELD UNITS** SHIFT-key provides a shortcut to the picklist menu⁴ for defining whether the field is specified and displayed in units of kilogauss (kG) or tesla (T). The selected option also applies to remote interface commands. The default setting is kilogauss.

1. The value is always displayed in current (A) when an installed persistent switch is in the *cooled state* since the value represents power supply current only, independent of magnet current/field.
2. Refer to section 3.10.2.2 on page 50.
3. Refer to section 3.10.2.4 on page 52.
4. Refer to section 3.10.3.4 on page 60.

Operation

Shift Key Commands : Persistent Switch Heater Current

3.7.8 Persistent Switch Heater Current SHIFT-key

```
+50.00 A - PSwitch Current (mA)
+0.50 Vs      10.0
```

Use of the **P. SWITCH HTR. CUR. SHIFT**-key provides a shortcut to the menu¹ for setting persistent switch heater current. The value can be set to between 0.0 and 125.0 mA. The default value is 10.0 mA unless preset by AMI to match a specific superconducting magnet.

3.7.9 Stability SHIFT-key

Use of the **STAB. SHIFT**-key provides a shortcut to the menu for defining the Model 430 stability setting. The stability setting is specified in percent and controls the transient response and stability of the system. The valid input range is from 0.0 to 100.0%. The default value is 0.0% unless preset by AMI to match a specific superconducting magnet.

See section 3.10.2.1 on page 48 for details of how to determine the stability setting to use.

3.7.10 Vs <> Vm SHIFT-key

The **Vs <> Vm SHIFT**-key is used to toggle the voltage display between display of the voltage across the magnet (**Vm**) and the power supply output voltage (**Vs**). See section 3.2.2 on page 24 for details.

3.7.11 Volt Meter SHIFT-key

The **VOLT METER SHIFT**-key is used to toggle the main display between display of a voltmeter indicating magnet voltage (**Vm**) or supply voltage (**Vs**), and display of ramp mode and persistent switch heater state. See section 3.2.4 on page 25 for details.

3.7.12 Fine Adjust SHIFT-key

The **FINE ADJUST SHIFT**-key is used to enable the use of the front panel fine adjust knob to adjust numeric values. See section 3.4 on page 26 for details.

3.7.13 Persist. Switch Control SHIFT-key

Refer to section 3.6.1 on page 29.

1. Refer to section 3.10.2.8 on page 55.

3.8 LED Indicators

The Model 430 Programmer has six front panel LED indicators. See figure with Table 1-1 on page 5 for the location of these indicators.

3.8.1 Power-on Indicator

The green power-on LED indicates that the Model 430 Programmer is powered on.

3.8.2 Magnet Status Indicators

Four LEDs are grouped together to show the magnet status.



Figure 3-6. Magnet Status LED Indicators.

3.8.2.1 Field At Target Indicator

The green **FIELD AT TARGET** LED indicates that the current is at the target value. If the magnet is not in persistent mode (persistent switch heater is on), then this is an indication that the magnet field has reached the target value. If the magnet is in persistent mode, then this is an indication that the current being supplied to the magnet system has reached the target value.

3.8.2.2 Magnet In Persistent Mode Indicator

Caution

*If the Model 430 Programmer power is turned off while the persistent switch is heated, persistent switch heating will be lost and the magnet will enter persistent mode. The Model 430 will not have a record of that event. Therefore the **MAGNET IN PERSISTENT MODE** LED state will be incorrect (remain **OFF**) when the Model 430 Programmer power is restored.*

Caution

*If the Model 430 Programmer power supply system is powered off and moved from one magnet system to another, the **MAGNET IN PERSISTENT MODE** LED may not correctly indicate the state of the*

Operation

LED Indicators : Current Leads Energized

magnet system until the first time the persistent switch heater is turned off.

Also, should the magnet quench while the magnet is in persistent mode and the Model 430 Programmer is off, the persistent mode indicator LED will be incorrect when the Model 430 Programmer is turned on again.

The green **MAGNET IN PERSISTENT MODE** LED indicates that the persistent switch heater is off, and that when it was turned off, the magnet had greater than 100 mA of current flowing through it. The state of this LED is kept in nonvolatile memory when the Model 430 is powered off, so that the LED state is retained even during a power cycle of the Model 430. Thus, the **MAGNET IN PERSISTENT MODE** LED is an indicator that the magnet is persistent and has at least *some* persistent field.

3.8.2.3 Current Leads Energized Indicator

The blue **CURRENT LEADS ENERGIZED** LED indicates that at least 100 mA of current is flowing in the Model 430 power supply system output current leads.

3.8.2.4 Magnet Quench Indicator

The red **MAGNET QUENCH** LED indicates that a magnet quench condition has been detected. See section 3.15 on page 86 for details.

3.8.3 SHIFT Indicator

The green **SHIFT** LED indicates that the **SHIFT** key has been pressed, and the next numeric keypad key pressed will actuate the shifted function (shown in light blue) rather than the numeric keypad function. See section 3.7 on page 32 for details of **SHIFT** key use.

3.9 Setup Menu

Setup of the Model 430 Programmer requires the user to navigate the setup menu. Navigation of the setup menu is very intuitive — quite similar, for example, to the use of a cell phone menu.

3.9.1 Entering / Exiting Setup Menu

To enter the setup menu, simply press the **MENU** key. When in any of the setup menus, pressing the **MENU** key will exit the setup menu. The **MENU** key toggles the Model 430 Programmer in and out of setup mode. Alternately, if the top level setup menu is being displayed, pressing the **ESC** key exits the setup menu.

Operation

Setup Menu : Navigation

3.9.2 Menu Navigation

Pressing the MENU key enters the menu structure at the top level. The display will look approximately as shown below:

```
+0.00 A - Setup Mode (Select one)
+0.50 Us ← ▶Supply      Load      Misc →
```

The item selector (▶) points to whichever submenu was last used. The left and right arrows at the ends of the displayed submenu selections indicate that there are other submenu selections off screen, to the left and/or right of the submenu selections shown.

The left and right *keypad* arrows (to the left and right of the MENU key) move the item selector between the different submenu items. Pressing the left keypad arrow moves the item selector one item to the left and pressing the right keypad arrow moves the item selector one item to the right. When the last item is reached, and the right keypad arrow is pressed, the item selector will move to the first item. Likewise, when the item selector is pointing to the first item, and the left keypad arrow is pressed, the item selector will move to the last item.

Pressing the ENTER key opens the submenu to which the item selector is pointing when the ENTER key is pressed. See sections 3.10.1 on page 43 through 3.10.5 on page 70 for detailed descriptions of each submenu.

Pressing the ESC key exits a submenu and moves the next higher level submenu if it exists. If the top level setup menu is being displayed, pressing the ESC key exits the setup menu.

3.10 Setup Submenu Descriptions

When a submenu is entered by selecting a submenu item and pressing ENTER (see section 3.9.2 on page 42 for details of menu navigation), the

Operation

Setup Submenu : Supply

user will be able to edit parameters under that submenu. See setup menu structure in Figure 3-7 below.

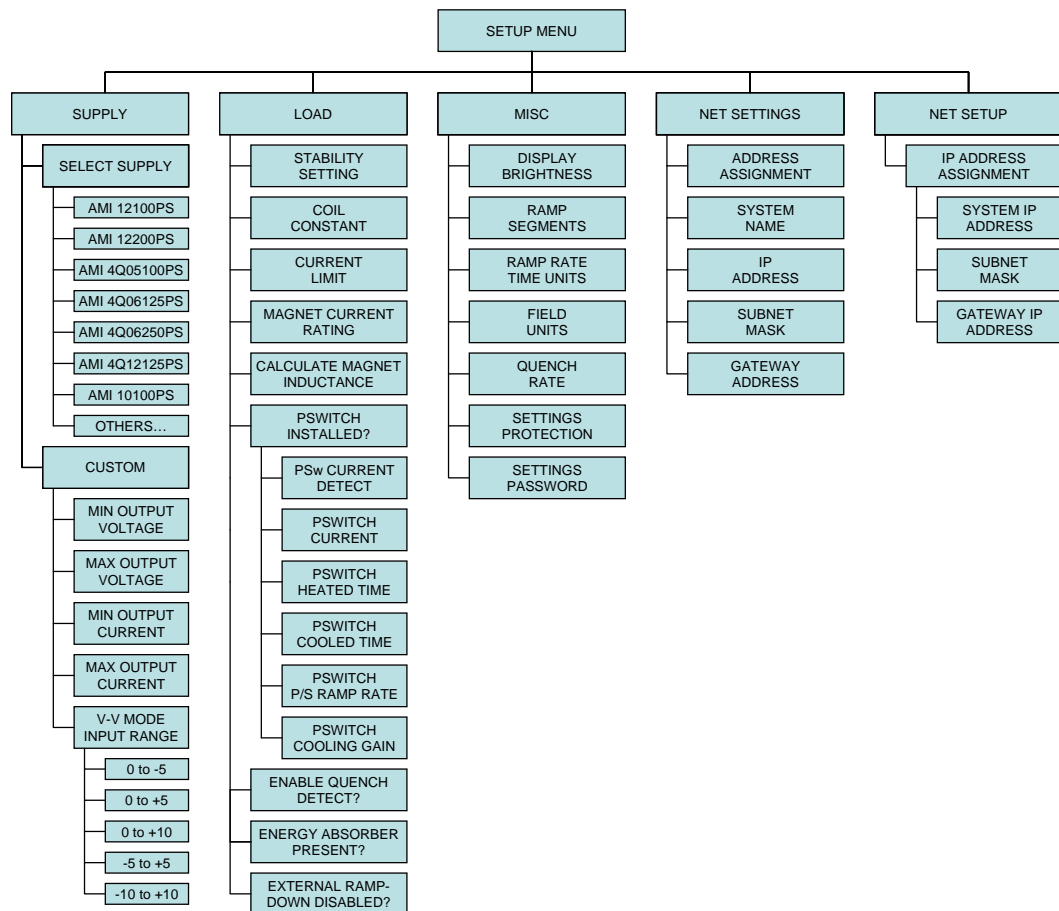

Figure 3-7. Setup Menu Structure

3.10.1 Supply Submenu

The Model 430 Programmer has been configured as part of the 4Q12125PS-430 Power Supply System. It should not be necessary to change this selection. However, the Supply submenu information that follows in Section 3.10.1 is provided in the event that the power supply system/model must be changed.

The Supply submenu provides for the specification of the *power supply parameters*. If you wish to set the limits of operation for a connected magnet, refer to the Current Limit¹ and the Voltage Limit² configuration sections.

1. Refer to section 3.10.2.4 on page 52.
2. Refer to section 3.7.2 on page 36.

Operation

Setup Menu : Supply

If using a standard power supply supported by AMI, selecting a power supply within the Select Supply picklist sets all the remaining parameters in the supply submenu per Table 3-2 on page 45.

Note

The Supply submenu is unique in that it has only the Select Supply picklist as a sublevel (unless Custom is chosen from the picklist of Select Supply options). For this reason, picklist entry is active as soon as the Supply submenu is selected; it is not necessary to first press enter to make picklist entry active in the Select Supply picklist. Also, pressing ESC while within the Select Supply picklist not only makes picklist entry inactive and sets the picklist selection back to where it was when the Supply submenu was selected; it also exits the Select Supply picklist.

3.10.1.1 Select Supply Picklist

```
+0.00 A - Select Supply*  
+0.50 Us ← ▶AMI 4006125PS →
```

The Select Supply picklist provides a set of picklist items that contain *presets for standard AMI power supplies*. The left and right keypad arrows are used to cycle through the list of selections. When the item selector points at the desired power supply in the picklist, **ENTER** is pressed to select that power supply; all power supply parameters are set when the power supply model is selected. Pressing **ESC** while viewing the Select Supply picklist leaves the power supply selection where it was when the Supply submenu was selected, and exits the Select Supply picklist. The available Select Supply picklist values and associated power supply parameters are provided in Table 3-2 on page 45.

Operation

Setup Menu : Supply

Table 3-2. Select Supply picklist values and associated parameters.

Power Supply	Min Output Voltage (V)	Max Output Voltage (V)	Min Output Current (A)	Max Output Current (A)	V-V Mode Input Range (V)		
AMI 08150PS	0	+8.000	+0.000	+150.000	+0.000 to +10.000		
AMI 12100PS	+0.000	+12.000	+0.000	+100.000	+0.000 to +10.000		
AMI 12200PS				+200.000			
AMI 4Q05100PS	-5.000	+5.000	-100.000	+100.000	-10.000 to +10.000		
AMI 4Q06125PS	-6.000	+6.000	-125.000	+125.000			
AMI 4Q06250PS			-250.000	+250.000			
AMI 4Q12125PS	-12.000	+12.000	-125.000	+125.000			
AMI 10100PS	+0.000	+10.000	+0.000	+100.000	+0.000 to +5.000		
AMI 10200PS				+200.000			
AMI 05100PS		+10.000 ^a		+100.000	+0.000 to +10.000		
AMI 05200PS				+200.000			
AMI 05300PS				+300.000			
AMI 05400PS				+400.000			
AMI 05500PS				+500.000			
HP 6260B				+100.000			
Kepeco BOP 20-5M ^b		-10.000		+10.000	-5.000	+5.000	-10.000 to +10.000
Kepeco BOP 20-10M ^b					-10.000	+10.000	
Xantrex XFR 7.5-140	+0.000	+7.500	+0.000	+140.000	+0.000 to +10.000		
Custom... ^c	-20.000	+20.000	-200.000	+200.000	-10.000 to +10.000		

- The individual 05100PS power supply unit will source +10.000 Vdc at 100 A. However, the standard configuration of this series of power supplies includes the Model 601 Energy Absorber to provide bipolar operation. The 05x00-430-601 series of power supply systems provides a maximum available voltage to the load of ± 5.000 Vdc at multiples of 100 A, up to 500 A depending on the system selected.
- The Kepeco BOP power supplies are limited to only one-half the output voltage range since the supplies are designed to safely *dissipate* only one-half the rated power output.
- The values shown for the Custom... option are defaults. The user should enter the appropriate values within the respective submenus. Custom values, once entered, are saved in nonvolatile memory.

Note

The current must be less than 0.1% of I_{max} in order to change the Select Supply picklist value. If a change is attempted with current above this value, the Model 430 Programmer will beep and ignore

Operation

Setup Menu : Supply

the keypress. Power supply selection should also preferably be performed with the power supply off for maximum safety.

The power supply settings define the output voltage and current ranges for a specific power supply. For example, V-I diagrams are presented in Figure 3-8 for the AMI 12100PS and AMI 4Q06125PS selections. The AMI 12100PS operates as a one-quadrant system without the addition of an energy absorber. As shown in the diagram, with the addition of an AMI Model 601 energy absorber, the AMI 12100PS system can function as a two-quadrant supply providing +5 V to -5 V at the power supply system output terminals. The AMI 4Q06125PS power supply operates as a four-quadrant power supply without the addition of an energy absorber.

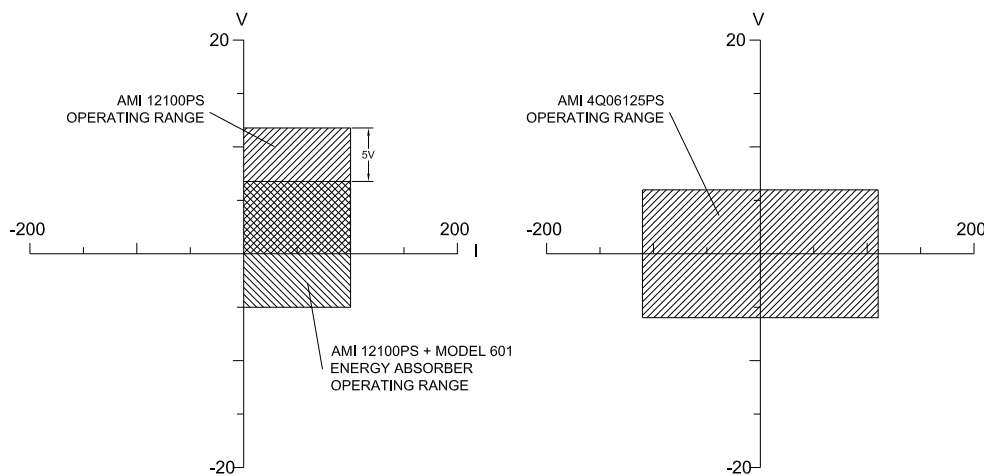

Figure 3-8. Example Power Supply Outputs

The addition of an energy absorber to the system does not change the capabilities of the power supply itself (or the values entered for the supply). The addition of an energy absorber does, however, change the *system* operating ranges per the example of Figure 3-8.

3.10.1.1.1 Custom... Picklist Item

Custom... is a unique Select Supply picklist item. When selected, it opens a deeper submenu in which the custom power supply parameters (Min Output Voltage, Max Output Voltage, Min Output Current, Max Output Current and V-V Mode Input Range) are entered. Entry of each of these parameters is described below.

Operation

Setup Menu : Supply

3.10.1.1.1 Min Output Voltage

```
+0.00 A - Min Output Voltage (V)
+0.00 Vs -6.000
```

The minimum output voltage is specified in volts (V) and reflects the minimum output voltage compliance of a connected power supply. The valid range is 0.000 to -20.000 V, and can be set by using either the numeric keypad per section 3.3 on page 25 or the fine adjust knob (section 3.4 on page 26). A unipolar power supply has a minimum output voltage of 0.000 V.

3.10.1.1.2 Max Output Voltage

```
+0.00 A - Max Output Voltage (V)
+0.00 Vs +6.000
```

The maximum output voltage is specified in volts (V) and reflects the maximum output voltage compliance of a connected power supply. The valid range is +0.001 to +20.000 V, and can be set by using either the numeric keypad per section 3.3 on page 25 or the fine adjust knob (section 3.4 on page 26).

3.10.1.1.3 Min Output Current

```
+0.00 A - Min Output Current (A)
+0.00 Vs +0.000
```

The minimum output current is specified in amperes (A) and reflects the minimum output current capacity of a connected power supply. The valid range is 0.000 to -2000.000 A¹, and can be set by using either the numeric keypad per section 3.3 on page 25 or the fine adjust knob (section 3.4 on page 26). A *unipolar* power supply has a minimum output current of 0.000 A.

1. The minimum and maximum output currents are bounded by the Model 430 Programmer configuration (refer to specifications on page 8 and in the Appendix). The entered value cannot exceed the programmable limits.

Operation

Setup Submenu : Load

3.10.1.1.1.4 Max Output Current

```
+0.00 A - Max Output Current (A)
+0.00 Us +100.000
```

The maximum output current is specified in amperes (A) and reflects the maximum output current capacity of a connected power supply. The valid range is 0.001 to +2000.000 A¹, and can be set by using either the numeric keypad per section 3.3 on page 25 or the fine adjust knob (section 3.4 on page 26).

3.10.1.1.1.5 V-V Mode Input Range

```
+0.00 A - V-V Mode Input Range (V)
+0.00 Us ▶-10.000 to +10.000
```

The voltage-to-voltage mode input range defines the remote programming voltage input range required by the connected power supply. The remote programming voltage is the output signal provided by the Model 430 Programmer as an input to the connected power supply.

This submenu item provides a picklist of six preset selections and does not allow numeric entry of a range. The picklist values are shown in Table 3-3 below.

Table 3-3. V-V Mode Input Range Picklist Values

+0.000 to -5.000	+0.000 to +8.000
+0.000 to +5.000	-5.000 to +5.000
+0.000 to +10.000	-10.000 to +10.000

3.10.2 Load Submenu

When the Load submenu is selected, several parameters associated with the superconducting magnet load can be viewed and/or changed.

3.10.2.1 Stability Setting

```
+0.00 A - Stability Setting (%)
+0.50 Us 0.0
```

The stability setting is specified in percent and controls the transient response and stability of the system. The value can be set

Operation

Setup Menu : Load

by using either the numeric keypad per section 3.3 on page 25 or the fine adjust knob (section 3.4 on page 26). The valid range is from 0.0 to 100.0%. The default value is 0.0% unless preset by AMI to match a specific superconducting magnet.

Superconducting magnets *without a persistent switch* require¹ a specific Model 430 Programmer stability setting based on the magnet inductance as follows:

For magnet inductance \leq 100 Henries (H):

$$\text{Stability Setting} = (100 - H)$$

For magnet inductance $>$ 100 Henries:

$$\text{Stability Setting} = 0$$

The graph below may be used as a guide to set the stability setting for magnets *with a persistent switch* installed and inductance of less than 3 henries. Magnets with an inductance of greater than 3 henries that have a persistent switch installed should operate with a stability setting of 0.0%.

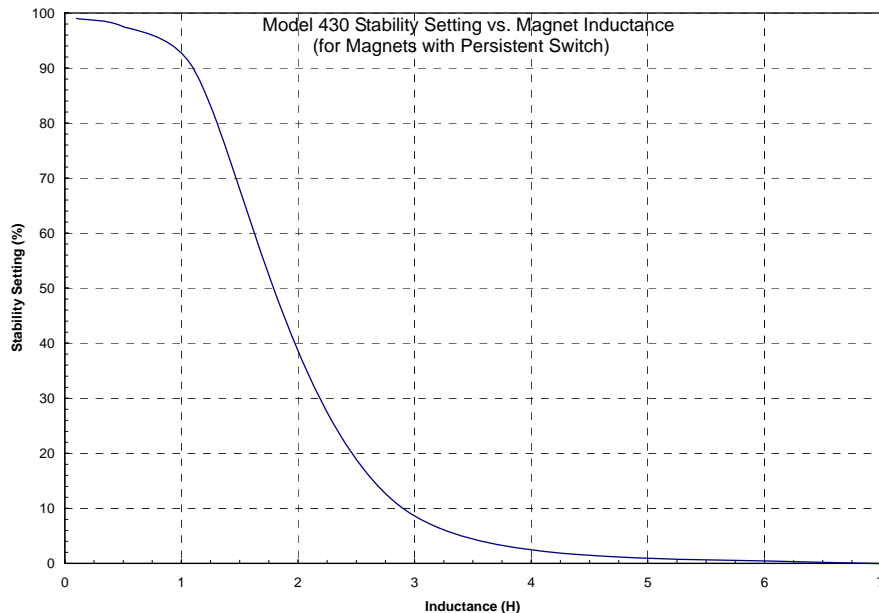

Figure 3-9. Stability Setting vs. Magnet (with PSwitch) Inductance

The Model 430 Programmer internal control loop gain is proportional to the multiplier (100% – [Stability Setting]), except that for a Stability of 100% the multiplier is set to a low non-zero value suitable for controlling current in a short circuit. For this

1. Effective with Model 430 firmware version 1.62.

Operation

Setup Menu : Load

reason, small changes in Stability Setting have a large effect on stability as the Stability Setting value approaches 100%. Changing the Stability Setting from 99.9% to 99.8% changes the gain multiplier from 0.1% to 0.2% (changing the gain multiplier by a factor of 2, a 100% increase in the gain multiplier). Note, however, that the same 0.1% change in Stability Setting from 90% to 89.9% only changes the gain multiplier from 10% to 10.1% (changing the gain multiplier by a factor of 1.01, a 1% change in gain multiplier). Likewise a 0.1% change in Stability Setting from 50% to 49.9% only changes the gain multiplier from 50% to 50.1% (changing the gain multiplier by a factor of only 1.002, a 0.2% increase in the gain multiplier).

What this means is that if the Stability Setting is being adjusted to *experimentally* determine its optimum setting (using the graph above as a starting point), no greater than 0.1% changes should be made above 98%, no greater than 0.2% changes should be made between 94% and 98%, no greater than 0.5% changes should be made between 84% and 94%, no greater than 2% changes should be made between 44% and 84% and no greater than 5% changes should be made below 44%. See the summary in the table below.

Table 3-4. Maximum Recommended Stability Setting Changes

Stability Setting Range	Maximum Recommended Stability Setting Change
98% to 100%	0.1%
94% to 98%	0.2%
84% to 94%	0.5%
44% to 84%	2%
0% to 44%	5%

3.10.2.2 Coil Constant

```
+0.00 A - Coil Constant (kG/A)
+0.50 Us      0.900000
```

The coil constant is a scaling factor which converts the current to kilogauss (kG) or tesla (T). It is also often referred to as the *field-to-current ratio*. The coil constant is specified in kilogauss/ampere or tesla/ampere. The value can be set by using either the numeric keypad per section 3.3 on page 25 or the fine adjust knob (section 3.4 on page 26). If the coil constant value is 0.0 kG/A (or 0.0 T/A), then no conversion from amperes to kilogauss or tesla is

Operation

Setup Menu : Load

performed — all operations will be performed and displayed in terms of amperes. Values from 0.001 to 999.99999 are acceptable for coil constant. The default value is 1.00000 kG/A (or 0.10000 T/A) unless preset by AMI to match a specific superconducting magnet.

If the coil constant is not explicitly stated within a superconducting magnet's specifications, the value can be obtained by dividing the rated field by the rated current. Note that 1 T = 10 kG.

3.10.2.3 Magnet Current Rating

Caution

The Magnet Current Rating is normally set to match a specific superconducting magnet. The setting should not be changed unless a different magnet is to be used; always refer to the magnet specification before changing the Magnet Current Rating.

```
+0.00 A  F Magnet Current Rating (A)
+0.00 Vm  ±100.000
```

A magnet operates within the capabilities of the associated power supply. Since the supply must be selected from the available standard ratings, the current limit of the supply, which is not user-adjustable, is almost always higher than the Magnet Current Rating.

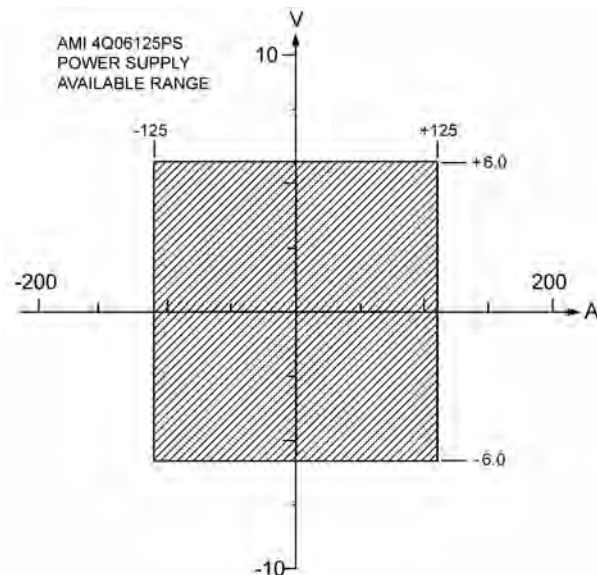

Figure 3-10. Typical Power Supply Self-Limits

The Magnet Current Rating is normally preset by AMI to match a specified superconducting magnet. If AMI is not supplying the

magnet, and specific magnet data has not been provided by the customer, the Model 430 will ship with Magnet Current Rating set at the default value of 80 A. Figure 3-11 shows the default Magnet Current Rating as set within the 4Q06125PS power supply limits.

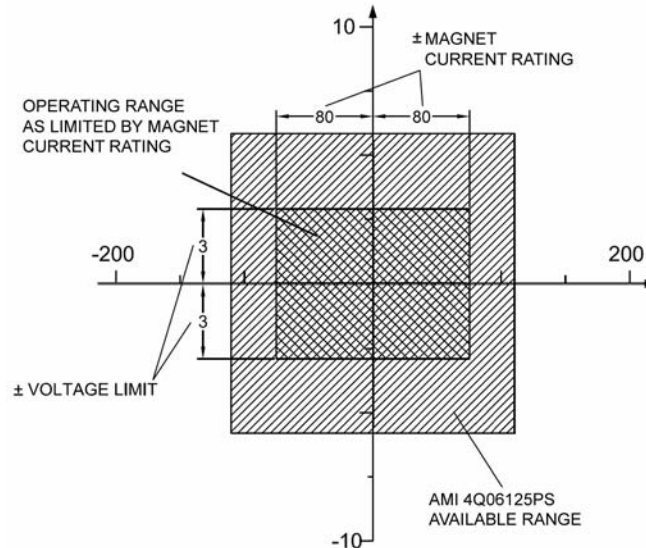

Figure 3-11. Magnet Current Rating Set Within Supply Range

The Magnet Current Rating can be set by using either the numeric keypad per section 3.3 on page 25 or the fine adjust knob (section 3.4 on page 26). The Model 430 Programmer will beep once and deny the change if the user attempts to set the Magnet Current Rating below the present Target Field Setpoint.

If a lower current limit is required for testing or other purposes, the Current Limit (see section 3.10.2.4) can be set by the user to limit the magnet current to values *lower* than the Magnet Current Rating.

3.10.2.4 Current Limit

```
+0.00 A - Current Limit (A)
+0.50 Vs ±50.000
```

The current to the load will be limited by the lower of the two Model 430 current limits, the Magnet Current Rating¹ or Current Limit setting.

1. Refer to section 3.10.2.3 on page 51.

Operation

Setup Menu : Load

The Current Limit setting can be used to limit the magnet current to values *lower* than the Magnet Current Rating for testing or other purposes (refer to Figure 3-12).

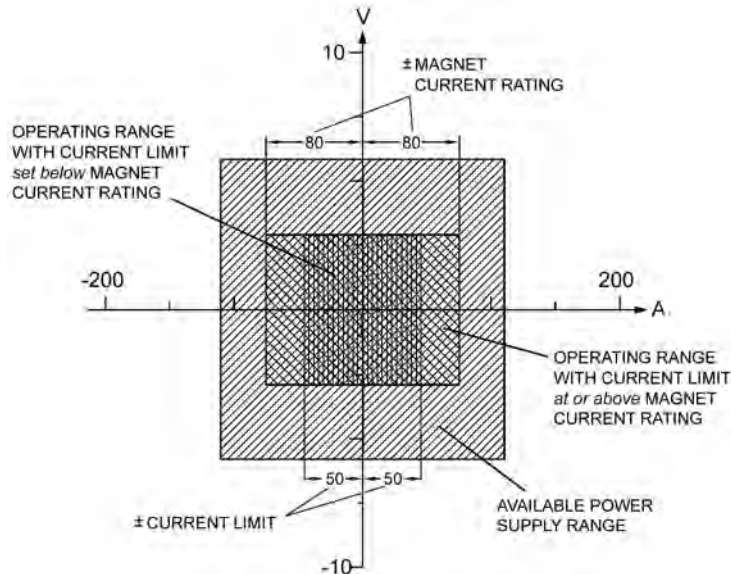

Figure 3-12. Example Current Limit Setup

The value can be set by using either the numeric keypad per section 3.3 on page 25 or the fine adjust knob (section 3.4 on page 26). The Current Limit is specified as an absolute value, but if the power supply is four quadrant, the Current Limit applies to both the positive and the negative current direction (current limit symmetry). The Model 430 Programmer will beep once and deny the change if the user attempts to set the Current Limit below the present Target Field Setpoint.

3.10.2.5 Calculate Magnet Inductance

```
+00.00 A - Magnet Inductance (H)
+0.00 Vs  ►Calculate
```

This menu pick will automatically determine the inductance of the load magnet. The inductance is determined by measuring the voltage developed across the magnet (V_m) with a fixed di/dt (current rate-of-change in A/sec) passed through the load. *The function must be executed with the magnet ramping.*¹ After the function is executed by pressing the **ENTER** key, the algorithm will wait for 2 seconds to allow the current charge rate to stabilize and

1. Refer to section 3.12.3 on page 76.

Operation

Setup Menu : Load

then makes the voltage and current measurements, calculates the inductance and then displays the result.

```
+46.19 A  ↑  Magnet Inductance (H)
+0.50 Vs          32.13
```

3.10.2.6 PSwitch Installed

```
+50.00 A  -  PSwitch Installed?
+0.50 Vs   NO  ►YES
```

This picklist value indicates whether or not a persistent switch is installed. If YES is selected, the PSwitch Current Detect, PSwitch Current, PSwitch Heated Time, PSwitch Cooled Time, PSw P/S Ramp Rate, and PSwitch Cooling Gain settings are made available within the Load submenu. If NO is selected, these settings are *not* made available within the Load submenu and the **PERSIST SWITCH CONTROL** key becomes inoperable. The default value is YES unless preset by AMI to match a specific superconducting magnet.

3.10.2.7 PSwitch Current Detect (mA)

```
+00.00 A  P  PSwitch Current Detect(mA)
+0.50 Vs   ►Auto detect
```

This function will automatically determine the proper value of heater current in a persistent switch installed on a magnet connected to the power supply system. The power supply should be energized and at zero current. When the **ENTER** key is pressed to start the process, the following occurs:

1. The persistent switch current is set to 0.1 mA.
2. The power supply current is ramped to 2 A at 0.1 A/sec.
3. After the power supply current reaches 2 A, the persistent switch current is slowly increased (as shown on the display) until the Model 430 Programmer detects a change in the load, indicative of the persistent switch transitioning from superconducting to resistive. Before this transition is detected, the display will show the heater current value as it is increased in the persistent switch

Operation

Setup Menu : Load

heater; the magnet current is changed back to zero during this process.

```
+2.00 A  P PSwitch Current Detect(mA)
+0.50 Us  Detecting... (20.7mA)
```

- 5 mA is added to the current that was present during the superconducting to resistive transition and that value of current is displayed.

```
+00.00 A  P PSwitch Current Detect(mA)
+0.50 Us  ▶ 37.2
```

Note

If the PSw current determined by this method is accepted as described below, the magnet will be in the heated switch mode at zero amps being delivered to the magnet.

- If the **ENTER** key is pressed, the determined value of PSw current is stored in the Model 430 Programmer. If the escape key is pressed, the value determined in step 4, above is discarded and the previously set persistent switch current is retained.

3.10.2.8 PSwitch Current

```
+50.00 A  - PSwitch Current (mA)
+0.50 Us  10.0
```

The persistent switch heater current can be set to any value between 0.0 and 125.0 mA. The value can be set by using either the numeric keypad per section 3.3 on page 25 or the fine adjust knob (section 3.4 on page 26). The default value is 10.0 mA unless preset by AMI to match a specific superconducting magnet.

3.10.2.9 PSwitch Heated Time

```
+50.00 A  - PSwitch Heated Time (sec)
+0.50 Us  20
```

The persistent switch heated time is the amount of time required for the persistent switch to heat completely and become fully normal (resistive). The time may be set to any value between 5 and

Operation

Setup Menu : Load

120 seconds¹. The value can be set by using either the numeric keypad per section 3.3 on page 25 or the fine adjust knob (section 3.4 on page 26). The default is 20 seconds unless preset by AMI to match a specific superconducting magnet.

During the persistent switch heating period, the Model 430 Programmer ramping functions are disabled. The time delay is necessary to ensure that the Model 430 will not switch to the higher gain required for proper magnet operation before the magnet is actually available in the circuit (not being shunted by the persistent switch). If magnet operation is not stable after expiration of the heating period, increase the heated time to allow more time for the switch to heat. The default value of 20 seconds is adequate for the majority of wet and dry persistent switches.

3.10.2.10 PSwitch Cooled Time

```
+50.00 A - PSwitch Cooled Time (sec)
+0.50 Us      20
```

The PSwitch Cooled Time is the amount of time required for the persistent switch to cool completely and become fully superconducting. The time may be set to any value between 5 and 3600 seconds². The value can be set by using either the numeric keypad per section 3.3 on page 25 or the fine adjust knob (section 3.4 on page 26). The default is 20 seconds unless preset by AMI to match a specific superconducting magnet.

During the persistent switch cooling period, the Model 430 Programmer ramping functions are disabled. The default value of 20 seconds is adequate for the majority of wet persistent switches. Persistent switches on conduction cooled magnets (dry switches) will require significantly longer cooling times than wet switches.

3.10.2.11 PSwitch Power Supply Ramp Rate

```
+50.00 A - PSw P/S Ramp Rate (A/sec)
+0.50 Us      10
```

The persistent switch power supply ramp rate is the rate at which the magnet power supply will automatically be ramped up or down while an installed persistent switch is in the cooled state. The rate

-
1. During the heating cycle, a "countdown" will be displayed indicating the number of seconds remaining in the cycle.
 2. During the cooling cycle, a "countdown" will be displayed indicating the number of seconds remaining in the cycle.

Operation

Setup Menu : Load

may be set to any value between 0.1 and 10 A/sec. The value can be set by using either the numeric keypad per section 3.3 on page 25 or the fine adjust knob (section 3.4 on page 26). The default is 10 A/sec unless preset by AMI to match a specific superconducting magnet system.

3.10.2.12 PSwitch Cooling Gain

```
+0.00 A  P PSwitch Cooling Gain (%)
+0.00 Us      0.0
```

The default cooling gain of 0.0% may be adequate for the majority of wet persistent switches. However, this setting may result in some magnet drift during persistent switch cooling, especially with conduction cooled switches. Increasing the cooling gain adds control loop gain during the switch cooling cycle. Too little may result in magnet drift during switch cooling. Too much may result in power supply instability during switch cooling, which could potentially prevent the switch from cooling. Most systems requiring some cooling gain to control magnet drift will likely work with value set to about 25%. The value can be set by using either the numeric keypad per section 3.3 on page 25 or the fine adjust knob (section 3.4 on page 26).

3.10.2.13 Enable Quench Detect

```
+50.00 A  - Enable Quench Detect?
+0.50 Us      NO  ►YES
```

The internal quench detection function of the Model 430 Programmer may be enabled or disabled according to the preference of the user. The default value is NO.

A user input for *external quench detection* is provided on the rear panel of the Model 430 Programmer¹. The external input overrides the internal quench detection function of the Model 430 and cannot be disabled. For further discussion of the quench detection logic and operation, please refer to section 3.15 on page 86.

1. Refer to section A.6.1 on page 150.

3.10.2.14 Energy Absorber Present

```
+50.00 A - Energy Absorber Present?  
+0.50 Us  ►NO    YES
```

This picklist value indicates whether an energy absorber, such as the AMI Model 601, is connected to the power supply system. The default setting is NO.

It is important for this setting to be correct since the internal gain tables of the Model 430 Programmer compensate for the additional load of the energy absorber if present. The increased gain when an energy absorber is present will decrease (but not eliminate) the time required for the system to “forward bias” the energy absorber.¹

3.10.2.15 Enable External Rampdown

```
+0.00 A - External Rampdown Enabled?  
+0.00 Us  ►NO    YES
```

The External Rampdown function of the Model 430 Programmer can be used to allow an external contact-signal to cause the magnet to be ramped to zero field (even if it is in persistent mode) should a fault or alarm occur in a magnet system. Signals such as low liquid levels, cryocooler compressor faults, or abnormal temperatures can be used to trigger a controlled magnet rampdown, even if the magnet is in persistent mode. Refer to section 6.2 on page 151.

The external rampdown function may be enabled or disabled according to the preference of the user. The default value is NO. With the exception of enable yes/no, the settings and parameters for the external rampdown function can be edited only via the remote interface (see section 4.5.5 on page 120).

A user input for *external rampdown detection* is provided on the rear panel of the Model 430 Programmer². For further discussion of the quench detection logic and operation, please refer to section 3.16 on page 88.

-
1. The Model 430 Programmer will bring the output voltage of the power supply to the point where the energy absorber can provide current to the magnet.
 2. Refer to section A.6.2 on page 151.

Operation

Setup Submenu : Misc

3.10.3 Misc Submenu

When the Misc submenu is selected, several miscellaneous parameters may be viewed and/or changed.

3.10.3.1 Display Brightness

```
+50.00 A - Display Brightness (%)
+0.50 Us  25   50   75   ►100
```

This picklist value controls display brightness. As shown above, there are four brightness settings from which to choose (25%, 50%, 75% and 100%). The default setting is 100%.

3.10.3.2 Ramp Segments

```
+50.00 A - Ramp Segments (1-10)
+0.50 Us  1
```

The ramp segments value specifies the number of current ranges which can be given unique ramp rate values. The default value is 1 unless preset by AMI to match a specific superconducting magnet.

When this value is 1, there is only one ramp rate for the Model 430 Programmer, used for the full available current range. For multiple ramp rates, set the value to the number of ramp segments desired (up to ten segments). See section 3.7.1 on page 33 for details regarding the use of ramp rate segments.

3.10.3.3 Ramp Rate Time Units

```
+50.00 A - Ramp Rate Time Units
+0.50 Us  ►Seconds  Minutes
```

This picklist value specifies the unit of time used to enter and the display ramp rate. If Seconds is selected, ramp rate is entered in A/s, kG/s or T/s; if Minutes is selected, ramp rate is entered in A/min, kG/min or T/min. The selected unit value also applies to remote interface commands. The default setting is Seconds.

Operation

Setup Menu : Misc

3.10.3.4 Field Units

```
+50.00 A - Field Units
+0.50 Us ▶ Kilogauss Tesla
```

This picklist value specifies whether the field is specified and displayed in units of kilogauss (kG) or tesla (T). The units selected also applies to remote interface commands. The default setting is kilogauss.

3.10.3.5 Quench Rate

```
+50.00 A P Quench Rate (default 1.5)
+0.50 Us 1.5
```

This picklist value specifies the sensitivity of the quench detection algorithm. The default value (1.5) will be appropriate for most magnets. Occasionally, some magnets quench very slowly and the value of this parameter may need to be adjusted to a lower value so that the Model 430 Programmer detects the slow quench. The available range for this parameter is 0.1 to 2.0. The value can be set by using either the numeric keypad per section 3.3 on page 25 or the fine adjust knob (section 3.4 on page 26). If the magnet quenches and the Model 430 Programmer does not select the quench, the value should be lowered until all quenches are detected.

3.10.3.6 Settings Protection

```
+50.00 A - Settings Protection
+0.50 Us ▶ Edit Settings
```

Settings Protection allows virtually¹ every command and menu/submenu setting to be protected from alteration or use. If a setting is locked, it cannot be used from the front panel without first unlocking the setting, which requires entering the correct password. Note that settings protection only applies to front panel access, and not to remote access (via Ethernet or RS-232).

The use of settings protection allows specific commands and/or settings to be locked by a magnet system “administrator,” so that

1. The one exception is the **RAMP TO ZERO** button which cannot be locked. Also, Magnet Inductance and Net Settings are not subject to locking due to their “read-only” nature.

Operation

Setup Menu : Misc

the general user cannot execute those commands and/or modify those settings. The implementation of settings protection in the Model 430 Programmer is very flexible; it allows as many or as few commands and/or settings to be locked as the magnet system administrator desires. The magnet system administrator may lock all but a few commands/settings, so that, for instance, the general user has access to only the **RAMP / PAUSE** and **RAMP TO ZERO** keys. Conversely, the administrator may lock, for instance, only the Current Limit setting from use by the general user.

If an attempt is made to use a locked command or setting, the Model 430 Programmer beeps twice; the command is not accepted and the setting is not altered.

When **ENTER** is pressed to change settings protection, the password must be correctly entered before settings protection can be edited.

```
+50.00 A - Enter Password*  
+0.50 Us -
```

Using the keypad, type the numeric password (up to 4-digits) and press **ENTER**. The default password is 1234. If an incorrect password is entered, the Model 430 Programmer beeps and again prompts for the password. Once the password has been correctly entered, the protection value (Locked or Unlocked) can be edited for each setting (see sections 3.10.3.6.1 through 3.10.3.6.25 below). The default protection value for all settings is Unlocked.

Note

Once the password has been correctly entered, if no keys are pressed for one minute, the Settings Protection submenu will be exited, and the password must be entered again if further changes to settings protection are desired.

If the correct password has been forgotten, contact AMI Technical Support for assistance. To change the password, see section 3.10.3.7 on page 67.

Operation

Setup Menu : Misc

3.10.3.6.1 PSwitch Control Lock

```
+50.00 A - PSwitch Control Lock
+0.50 Us   Locked   ▶Unlocked
```

This picklist value specifies whether use of the **PERSIST. SWITCH CONTROL** key is locked or unlocked. The default value is Unlocked.

3.10.3.6.2 Target Field Setpt Lock

```
+50.00 A - Target Field Setpt Lock
+0.50 Us   Locked   ▶Unlocked
```

This picklist value specifies whether use of the **TARGET FIELD SETPOINT** key is locked or unlocked. The default value is Unlocked.

3.10.3.6.3 Ramp / Pause Lock

```
+50.00 A - Ramp / Pause Lock
+0.50 Us   Locked   ▶Unlocked
```

This picklist value specifies whether use of the **RAMP / PAUSE** key is locked or unlocked. The default value is Unlocked.

3.10.3.6.4 Ramp To Zero Lock

```
+50.00 A - Ramp To Zero Lock
+0.50 Us   Locked   ▶Unlocked
```

This picklist value specifies whether use of the **RAMP TO ZERO** key is locked or unlocked. The default value is Unlocked.

3.10.3.6.5 Ramp Rate Settings Lock

```
+50.00 A - Ramp Rate Settings Lock
+0.50 Us   Locked   ▶Unlocked
```

This picklist value specifies whether ramp rate settings are locked or unlocked. Ramp rate settings protected by this setting are: use of the **RAMP RATE SHIFT**-key menu, editing of the Ramp Segments

Operation

Setup Menu : Misc

value (under the Misc submenu) and editing of the Ramp Time Units value (under the Misc submenu). The default value is Unlocked.

3.10.3.6.6 Power Supply Lock

```
+50.00 A - Power Supply Lock
+0.50 Us   Locked   ▶Unlocked
```

This picklist value specifies whether the Select Supply picklist value is locked or unlocked. If the Select Supply value is Custom..., then setting Power Supply Lock to Locked also prevents the custom power supply parameters (Min Output Voltage, Max Output Voltage, Min Output Current, Max Output Current and V-V Mode Input Range) from being edited. The default value is Unlocked.

3.10.3.6.7 Voltage Limit Lock

```
+50.00 A - Voltage Limit Lock
+0.50 Us   Locked   ▶Unlocked
```

This picklist value specifies whether use of the **VOLTAGE LIMIT SHIFT**-key menu is locked or unlocked. The default value is Unlocked.

3.10.3.6.8 Reset Quench Lock

```
+50.00 A - Reset Quench Lock
+0.50 Us   Locked   ▶Unlocked
```

This picklist value specifies whether use of the **RESET QUENCH SHIFT**-key command is locked or unlocked. The default value is Unlocked.

3.10.3.6.9 Incr./Decr. Field Lock

```
+50.00 A - Incr./Decr. Field Lock
+0.50 Us   Locked   ▶Unlocked
```

This picklist value specifies whether use of the **INCR. FIELD** and **DECR. FIELD SHIFT**-key commands is locked or unlocked. The default value is Unlocked.

Operation

Setup Menu : Misc

3.10.3.6.10 Field <> Current Lock

```
+50.00 A - Field <> Current Lock
+0.50 Vs   Locked   ▶Unlocked
```

This picklist value specifies whether use of the **FIELD <> CURRENT SHIFT**-key command is locked or unlocked. The default value is Unlocked.

3.10.3.6.11 Field Units Lock

```
+50.00 A - Field Units Lock
+0.50 Vs   Locked   ▶Unlocked
```

This picklist value specifies whether the Field Units value is locked or unlocked (whether accessed through the **FIELD UNITS SHIFT**-key menu or under the Misc submenu). The default value is Unlocked.

3.10.3.6.12 Stability Setting Lock

```
+50.00 A - Stability Setting Lock
+0.50 Vs   Locked   ▶Unlocked
```

This picklist value specifies whether the Stability Setting value is locked or unlocked (whether accessed through the **STAB. SHIFT**-key menu or under the Load submenu). The default value is Unlocked.

3.10.3.6.13 Vs <> Vm Lock

```
+50.00 A - Vs <> Vm Lock
+0.50 Vs   Locked   ▶Unlocked
```

This picklist value specifies whether use of the **Vs <> Vm SHIFT**-key command is locked or unlocked. The default value is Unlocked.

Operation

Setup Menu : Misc

3.10.3.6.14 Volt Meter Lock

```
+50.00 A - Volt Meter Lock
+0.50 Vs  Locked    ▶Unlocked
```

This picklist value specifies whether use of the **VOLT METER** SHIFT-key command is locked or unlocked. The default value is Unlocked.

3.10.3.6.15 Fine Adjust Lock

```
+50.00 A - Fine Adjust Lock
+0.50 Vs  Locked    ▶Unlocked
```

This picklist value specifies whether use of the **FINE ADJUST** SHIFT-key command is locked or unlocked. The default value is Unlocked.

3.10.3.6.16 Coil Constant Lock

```
+50.00 A - Coil Constant Lock
+0.50 Vs  Locked    ▶Unlocked
```

This picklist value specifies whether the Coil Constant value (under the Load submenu) is locked or unlocked. The default value is Unlocked.

3.10.3.6.17 Current Limit Lock

```
+50.00 A - Current Limit Lock
+0.50 Vs  Locked    ▶Unlocked
```

This picklist value specifies whether the Current Limit value (under the Load submenu) is locked or unlocked. The default value is Unlocked.

Operation

Setup Menu : Misc

3.10.3.6.18 Mag Current Rating Lock

```
+0.00 A - Mag Current Rating Lock
+0.50 Us Locked ▶Unlocked
```

This picklist value specifies whether the Magnet Current Rating value (under the Load submenu) is locked or unlocked. The default value is Unlocked.

3.10.3.6.19 PSwitch Settings Lock

```
+50.00 A - PSwitch Settings Lock
+0.50 Us Locked ▶Unlocked
```

This picklist value specifies whether persistent switch settings are locked or unlocked. Persistent switch settings protected by this setting (all under the Load submenu) are: the PSwitch Installed picklist value, PSwitch Current Detect, the PSwitch Current value, the PSwitch Heated Time value, the PSwitch Cooled Time value, the PSwitch P/S Ramp Rate value, and the PSwitch P/S Cooling Gain value. The default value is Unlocked.

3.10.3.6.20 Quench Detect Lock

```
+50.00 A - Quench Detect Lock
+0.50 Us Locked ▶Unlocked
```

This picklist value specifies whether the Enable Quench Detect picklist value (under the Load submenu) is locked or unlocked. The default value is Unlocked.

3.10.3.6.21 Quench Rate Lock

```
+50.00 A - Quench Rate Lock
+0.50 Us Locked ▶Unlocked
```

This picklist value specifies whether the Quench Rate picklist value (under the Misc submenu) is locked or unlocked. The default value is Unlocked.

Operation

Setup Menu : Misc

3.10.3.6.22 Absorber Present Lock

```
+50.00 A - Absorber Present Lock
+0.50 Us   Locked   ▶Unlocked
```

This picklist value specifies whether the Energy Absorber Present picklist value (under the Load submenu) is locked or unlocked. The default value is Unlocked.

3.10.3.6.23 External Rampdown Lock

```
+0.00 A - External Rampdown Lock
+0.50 Us   Locked   ▶Unlocked
```

This picklist value specifies whether the external rampdown function (under the Load submenu) is locked or unlocked. The default value is Unlocked.

3.10.3.6.24 Display Brightness Lock

```
+50.00 A - Display Brightness Lock
+0.50 Us   Locked   ▶Unlocked
```

This picklist value specifies whether the Display Brightness picklist value (under the Misc submenu) is locked or unlocked. The default value is Unlocked.

3.10.3.6.25 Net Setup Lock

```
+50.00 A - Net Setup Lock
+0.50 Us   Locked   ▶Unlocked
```

This picklist value specifies whether the Net Setup submenu is locked or unlocked. The default value is Unlocked.

3.10.3.7 Settings Password

```
+50.00 A - Settings Password
+0.50 Us   ▶Change Password
```

Settings Password is a password protected submenu under the Misc submenu. It provides a means of changing the settings protection password.

Operation

Setup Submenu : Net Settings

When **ENTER** is pressed to change the settings protection password, the current password must be correctly entered before a new password can be entered.

```
+50.00 A - Enter Current Password*  
+0.50 Us -
```

Using the keypad, type the current 4-digit (maximum) numeric password and press **ENTER**. The default password is 1234. If an incorrect password is entered, the Model 430 Programmer beeps and again prompts for the password. Once the password has been correctly entered, the user is prompted for the new password.

```
+50.00 A - Enter New Password*  
+0.50 Us -
```

Using the keypad, type the new 4-digit (maximum) numeric password and press **ENTER**. The user is then prompted to re-enter the new password for confirmation.

```
+50.00 A - Enter New Password Again*  
+0.50 Us -
```

Using the keypad, again type the new 4-digit (maximum) numeric password and press **ENTER**. If the second password entry does not match the first password entry, the Model 430 Programmer beeps and the user is prompted again to re-enter the new password. The new password is not accepted until it is confirmed by entering the same password a second time. If **ESC** is pressed before confirmation is completed, the display returns to the Settings Password submenu, and the current password remains unchanged.

3.10.4 Net Settings Submenu

Selecting the Net Settings submenu allows all currently assigned network settings to be *viewed* (but not edited). To *edit* network settings, select the Net Setup submenu.

Operation

Setup Submenu : Net Settings

3.10.4.1 Addr Assignment (Present)

```
+50.00 A - Addr Assignment (Present)
+0.50 U= DHCP
```

This submenu item displays the currently selected method of IP address assignment. The value will either be DHCP or Static. The default value is DHCP, which means that the system IP address, the subnet mask and the gateway IP address are dynamically determined by the network DHCP server.

3.10.4.2 System Name (Present)

```
+50.00 A - System Name (Present)
+0.50 U= AMI
```

This submenu item displays the currently assigned system name (also known as *host name* or *computer name*), the *name* by which the Model 430 Programmer is identified on a network. This setting can *only* be modified using remote communications (either Ethernet or RS-232); it cannot be edited using the front panel keypad.

3.10.4.3 IP Address (Present)

```
+50.00 A - IP Address (Present)
+0.50 U= 0.0.0.0 (DHCP)
```

This submenu item displays the currently assigned system IP address for the Model 430 Programmer. The value in parentheses after the IP address value indicates how the IP address is assigned. DHCP indicates that the value is dynamically assigned by a DHCP server; Static indicates that the value is static, assigned by the Model 430 user. The default value is 0.0.0.0. However, since the default method of IP address assignment is by DHCP server, this value is typically set by the network DHCP server.

3.10.4.4 Subnet Mask (Present)

```
+50.00 A - Subnet Mask (Present)
+0.50 U= 0.0.0.0 (DHCP)
```

This submenu item displays the currently assigned subnet mask for the Model 430 Programmer. The value in parentheses after the subnet mask value indicates how the subnet mask is assigned.

Operation

Setup Submenu : Net Setup

DHCP indicates that the value is dynamically assigned by a DHCP server; Static indicates that the value is static, assigned by the Model 430 user. The default value is 0.0.0.0. However, since the default method of subnet mask assignment is by DHCP server, this value is typically set by the network DHCP server.

3.10.4.5 Gateway Address (Present)

```
+50.00 A - Gateway Address (Present)
+0.50 Us 0.0.0.0 (DHCP)
```

This submenu item displays the currently assigned gateway IP address for the Model 430 Programmer. The value in parentheses after the gateway IP address value indicates how the gateway IP address is assigned. DHCP indicates that the value is dynamically assigned by a DHCP server; Static indicates that the value is static, assigned by the Model 430 user. The default value is 0.0.0.0. However, since the default method of subnet mask assignment is by DHCP server, this value is typically set by the network DHCP server.

3.10.5 Net Setup Submenu

Selecting the Net Setup submenu allows network settings to be *edited* (except for the system name, which can only be modified using remote communications). Note also that the system IP address, the subnet mask and the gateway IP address can only be assigned by the user if the currently selected method of IP address assignment is Static; if the currently selected method of IP address assignment is DHCP, then these three values will be set by the network DHCP server.

3.10.5.1 IP Address Assignment

```
+50.00 A - IP Address Assignment
+0.50 Us  ▶DHCP  Static
```

This picklist value specifies method of IP address assignment. The value can be set to either DHCP or Static. If the value is DHCP, then the system IP address, the subnet mask and the gateway IP address are dynamically assigned by the network DHCP server. If the value is Static, then the system IP address, the subnet mask and the gateway IP address are assigned static values by the user. The default value is DHCP.

Operation

Setup Submenu : Net Setup

Note

If the IP Address Assignment value is changed, the Model 430 Programmer power must be cycled off for at least 15 seconds and then back on to complete the change. The previous value will continue to be used until the Model 430 is restarted.

3.10.5.2 System IP Address

```
+50.00 A - System IP Address
+0.50 Us  0.0.0.0
```

If IP Address Assignment is Static, then the system IP address can be assigned by the user. The default value is 0.0.0.0.

Note

This item is only available in the Net Setup submenu if IP Address Assignment is Static. If IP Address Assignment is DHCP, the system IP address is assigned by the network DHCP server and cannot be assigned by the user.

3.10.5.3 Subnet Mask

```
+50.00 A - Subnet Mask
+0.50 Us  0.0.0.0
```

If IP Address Assignment is Static, then the subnet mask can be assigned by the user. The default value is 0.0.0.0.

Note

This item is only available in the Net Setup submenu if IP Address Assignment is Static. If IP Address Assignment is DHCP, the subnet mask is assigned by the network DHCP server and cannot be assigned by the user.

3.10.5.4 Gateway IP Address

```
+50.00 A - Gateway IP Address
+0.50 Us  0.0.0.0
```

If IP Address Assignment is Static, then the gateway IP address can be assigned by the user. The default value is 0.0.0.0.

Note

This item is only available in the Net Setup submenu if IP Address Assignment is Static. If IP Address Assignment is DHCP, the gateway IP address is assigned by the network DHCP server and cannot be assigned by the user.

3.11 Example Setup

As a precursor to operating a superconducting magnet with the Model 430 Programmer and power supply, all of the setup items should be reviewed and set if necessary with appropriate values for the connected superconducting magnet.

Figure 3-13 (on the next page) shows an example magnet specifications sheet. Several parameters needed to operate the magnet are specified. These values should be entered into the appropriate setup menu of the Model 430 Programmer. For the purposes of this example, the AMI Model 4Q06125PS power supply will be assumed, since rated current for the example magnet is 85.6 A.

American Magnetics, Inc.



P.O. Box 2509, 112 Flint Road, Oak Ridge, TN 37831-2509
Phone: (865) 482-1056 Fax: (865) 482-5472
Internet: <http://www.americanmagnetics.com> E-mail: sales@americanmagnetics.com

MAGNET SPECIFICATIONS

AMI JOB #024856-2-1 MAGNET #33109

TYPE: **Solenoid**

MODEL: **Custom**

FOR: **A&W CryoEngineering, Ltd.**

DATE: **23 May 2008**

Rated Central Field @ 4.2K¹-----80 kG
Rated Current -----85.6 amps
Max. Field Tested -----82 kG
Field to Current Ratio -----934 gauss/amp
Homogeneity over a 1 cm DSV -----±0.5%
Measured Inductance -----9.7 henrys
Charging Voltage -----2.1 volts
Axial Clear Bore -----3.0 inches
Overall Length (flange to flange) -----4.74 inches
Maximum Outside Diameter -----6.4 inches
Weight -----41 lbs.
Recommended Persistent Switch Heater Current -----41 mA
Persistent Switch Heater Nominal Resistance²-----94.8 ohms
Magnet Resistance in Parallel with Switch²-----16.0 ohms
Mounting:3 holes tapped for M6 X 1.0 on top flange, equally spaced
on a 4.724 inch bolt circle diameter

1. Magnet not warranted for operation above 80 kG.
2. All resistance measurements made at room temperature.

EXCELLENCE IN MAGNETICS AND CRYOGENICS

Figure 3-13. Example Magnet Specification Sheet.

The Current Limit accessible in the Load submenu should be set to the rated current to prevent accidental operation of the magnet above rated field/current. The magnet specification sheet also indicates whether a persistent switch is installed and provides the recommended heating current. The persistent switch information is entered in the Load submenu.

If your magnet, Model 430 Programmer, and power supply were purchased as a system from AMI, the setup menus are preset by AMI to match the magnet purchased.

Table 3-5 provides a summary of the Model 430 Programmer setup parameters for this example.

Table 3-5. Example Setup Configuration

Parameter	Setting
Select Supply	AMI 4Q06125PS
Stability Setting (%)	0.0
Coil Constant ^a (kG/A)	0.934
Current Limit (A)	85.600
PSwitch Installed	YES
PSwitch Current (mA)	41.0
PSwitch Heated Time (sec)	20
PSwitch Cooled Time (sec)	20
PSwitch P/S Ramp Rate (A/sec)	10
Enable Quench Detect	YES
Energy Absorber Present	NO
Voltage Limit (V)	4.100 ^b
Ramp Rate (A/sec)	0.2165 ^c
Magnet Current Rating (A)	85.600
PSwitch Cooling Gain (%)	0.0%
Extern Rampdown Enabled	YES

- a. Also referred to as the Field-to-Current Ratio. Obtained by dividing the rated field by the rated current if not explicitly stated.
- b. Value is the 2.1 V charge rate plus allowances for power lead drop at the rated current.
- c. Value is obtained by dividing the magnet charging voltage (V) by the magnet inductance (H).

3.12 Ramping Functions

The ramping functions are used to control charging of the superconducting load. The Model 430 Programmer allows piecewise-linear charging profiles

Operation

Ramping Functions : States and Controls

to be defined and executed (up to 10 segments, each with a unique ramp rate). The basic charging equation for a superconducting magnet is:

$$V = L \frac{di}{dt}$$

where V is the charging voltage (V), L is the magnet inductance (H), and di/dt is the ramp rate (A/s). The relationship may also be defined in terms of a ramp rate in kG/s by the relationship:

$$V = \frac{L}{C} \frac{dB}{dt}$$

where C is the coil constant (or field-to-current ratio) in kG/A, and dB/dt is the ramp rate expressed in kG/s.

A desired ramp rate should be selected by the user and entered into the Model 430 Programmer. A Voltage Limit should also be specified that is greater than or equal to the voltage calculated from the equations above plus energy absorber voltage (if installed) plus power lead voltage drop (usually less than 2 V).

Once the ramp rate and Voltage Limit are specified, the Model 430 Programmer provides two modes of ramping: *manual* and *automatic*. Manual ramping will ramp to the Current Limit via manual direction control by the user. Automatic ramping will ramp to the target field/current automatically. Automatic ramping can be thought of as a “next point” operation, whereby the Model 430 determines the appropriate ramp direction based on the present magnet current and the target value.

Note

You may enter up to 10 digits beyond the decimal point within the ramping control menus. These extra digits are maintained in the internal memory of the Model 430 Programmer even though the full precision is not displayed after entry.

3.12.1 Ramping States and Controls

The ramping state may be one of several values as described in Table 3-6.

If the **RAMP / PAUSE** key is pressed while ramping, the PAUSED mode becomes active. To begin automatic ramping, press the **RAMP / PAUSE** key to deactivate the PAUSED mode. If manual ramping is desired, use either the **INCR. FIELD** or **DECR. FIELD SHIFT**-key for manual control of ramping up or ramping down, respectively.

Voltage limit and ramp rate may be specified from quickly accessible SHIFT-key menus from the front panel keypad¹. The settings for Voltage

Operation

Ramping Functions : Manual Ramping

Table 3-6. Ramp modes and descriptions.

Mode	Description
Ramping	Automatic ramping to the target field/current ^a is in progress.
Holding	The target field/current has been achieved and is being maintained.
Paused	Ramping is suspended at the field/current achieved at the time the PAUSED mode was entered.
Manual	Ramping is being controlled by the manual control (INCR. FIELD and DECR. FIELD) SHIFT-key functions available on the front panel.
Zeroing Current	RAMP TO ZERO is active, and the Model 430 Programmer is ramping current to 0 A.
Zero Current	RAMP TO ZERO is still active, and the current is less than 0.1% of I_{max} .
Heating Switch	The persistent switch heater has been activated. Ramping is disabled during the persistent switch heating period.
Cooling Switch	The persistent switch heater has been deactivated. Ramping is disabled during the persistent switch cooling period.

a. The target field/current setting is discussed in section 3.6.2.

Limit and ramp rate(s) are applicable to both manual and automatic ramping.

3.12.2 Manual Ramping

The INCR. FIELD and DECR. FIELD SHIFT-key functions control manual ramping. Manual ramping ramps field/current up or down at the defined ramp rate(s). See section 3.7.4 on page 37 and section 3.7.6 on page 38 for details regarding the use of these SHIFT-key functions.

3.12.3 Automatic Ramping

Automatic ramping differs from manual ramping in that the Model 430 Programmer automatically performs ramping in the appropriate direction to achieve the value of the target field/current setting. To use automatic ramping, enter the target field/current with which ramping is desired¹. If ramping is not PAUSED, ramping to the target field/current begins immediately. If ramping is PAUSED, ramping to the target field/current will begin when the RAMP / PAUSE key is pressed to take the Model 430

1. Refer to section 3.7.1 on page 33 and section 3.7.2 on page 36.

1. Refer to section 3.6.2 on page 31.

Operation

Ramping Functions : Ramping to Zero

Programmer out of PAUSED mode. The ramp rate will be controlled by the preset ramp rate variables as described in section 3.7.1 on page 33.

3.12.4 Ramping to Zero

Pressing the RAMP TO ZERO key activates an immediate ramp to zero field/current. See section 3.6.4 on page 31 for details.

3.12.5 Fine Adjust of Field / Current in Holding Mode

If the target field/current menu is active *and* the Model 430 Programmer is in HOLDING mode (indicated by a “-” Status Indicator), the fine adjust knob can be used to manipulate the output current. While at the target field/current menu, press **SHIFT**, followed by **FINE ADJUST**. This will allow fine adjustment of the field/current (see section 3.4).

+20.02 A	-	Target Current (A) †
+0.20 Us		+20.0239

When the fine adjust knob is turned the Model 430 Programmer will follow the target current as it is adjusted, at the defined ramp rate for the segment in which it is operating. Adjustment of the current is prevented from exceeding the Current Limit specified in the Load setup menu (see section 3.10.2.4 on page 52). The *resolution* of the adjustment is 15 digits, which is greater than the resolution of the display.

When the field/current is adjusted to the desired value, press the **ENTER** key to keep that value as the target field/current. If any other operation is performed before **ENTER** is pressed, the target field/current value will revert back to what it was before adjustment using the fine adjust knob was initiated, and the current will immediately begin ramping back to that value.

3.13 Persistent Switch Control

The Model 430 Programmer includes an integral persistent switch heater that provides the capability of controlling the persistent mode of the magnet either locally from the front panel of the Model 430 Programmer using the **PERSIST. SWITCH CONTROL** key¹, or remotely through a communications interface. The persistent mode of the magnet is indicated by the **MAGNET IN PERSISTENT MODE LED**².

-
1. Refer to section 3.6.1 on page 29.
 2. Refer to section 3.8.2.2 on page 40.

Operation

Persistent Switch Control : Initial Heating of the Switch

See section 3.6.1 on page 29 for details of the use of the **PERSIST. SWITCH CONTROL** key.

3.13.1 Procedure for Initial Heating of the Switch

The Model 430 Programmer remembers the state of the persistent switch during the time that the Programmer is de-energized. If the Model 430 is turned on when its shut down state was such that the persistent switch was heated and Programmer commanding zero current (the normal mode after the magnet has been discharged), the following screen will be displayed.¹

```
+0.00 A  F  Mode: Paused
+0.00 Us  PSwitch Heater: OFF
```

In order to charge the magnet, the persistent switch heater must be energized. Perform the following steps.

1. Turn on the persistent switch heater by pressing the **PERSIST. SWITCH CONTROL** key to heat the persistent switch heater.

```
+0.00 A  *  Mode: Heating Switch (4)
+0.00 Us  PSwitch Heater: ON
```

2. After the persistent switch heater has been heated for the preset heating time as set by the PSwitch Heated Time variable, the display will show the default display and wait at zero current for a command from the operator.

```
+0.00 A  F  Mode: Paused
+0.00 Us  PSwitch Heater: ON
```

3.13.2 Procedure for Entering Persistent Mode

In order to enter the persistent mode of magnet operation, the user should perform the following steps:

1. Use either automatic or manual ramping to achieve the desired field or current in the magnet.

1. Refer to section 3.1 on page 21.

Operation

Persistent Switch Control : Entering Persistent Mode

2. The Model 430 Programmer must be in either the HOLDING or PAUSED mode at the target field or current.
3. The Model 430 Programmer must be at the default field/current display.¹
4. Press the **PERSIST. SWITCH CONTROL** key to turn off the persistent switch heater current and automatically ramp the power supply to zero current:
 - a. After the **PERSIST. SWITCH CONTROL** key is pressed, the Model 430 Programmer requests that the **ENTER** key be pressed as a confirmation that the magnet should be placed in persistent mode.²

```
+50.00 A - Press ENTER to begin
+3.50 Us Persistent Mode
```

- b. When **ENTER** is pressed, the persistent switch is cooled for the preset persistent switch cooling time (set by the PSwitch Cooled Time variable³). The display indicates that the persistent switch is being cooled and indicates the number of seconds (4 in this example) remaining in the cooling cycle.

```
+50.00 A ♦ Mode: Cooling Switch (4)
+3.50 Us PSwitch Heater: OFF
```

- c. When the cooled time is complete, the green **MAGNET IN PERSISTENT MODE LED** will illuminate⁴ and the power supply will ramp to zero at the PSw P/S Ramp Rate value⁵.

```
+42.89 A ↓ Mode: Power Supply ramping
+3.38 Us to zero current
```

-
1. Refer to section 3.2.1 on page 23.
 2. Pressing the **ESCAPE** key will terminate the command and return the Model 430 Programmer to the default screen.
 3. Refer to section 3.10.2.10 on page 56.
 4. The threshold for this LED is 100 mA of magnet current.
 5. Refer to section 3.10.2.11 on page 56.

Operation

Persistent Switch Control : Entering Persistent Mode

Note

The magnet voltage (V_m) is monitored during the power supply ramp to zero. If the magnet voltage exceeds 0.5 V during this ramp, the ramp is paused and the Model 430 Programmer beeps to indicate the persistent switch did not transition to the superconducting state properly. If this error occurs, the Model 430 will ramp the current back to the value when the persistent switch was cooled,

```
+45.39 A  ↑  Mode: Power Supply Ramping  
+3.44 Vs  to match magnet field
```

and then heat the switch:

```
+50.00 A  ♦  Mode: Heating Switch  
+3.50 Vs  ***** PSW Lock Error *****
```

After the persistent switch heated time has elapsed, the display will indicate the persistent mode transition malfunction:

```
+50.00 A  -  Mode: Paused w/PSW error  
+3.50 Vs  Press ENTER to continue
```

*After pressing **ENTER**, the Model 430 Programmer will revert to the default field/current display.*

```
+50.00 A  P  Mode: Paused  
+3.50 Vs  PSwitch Heater: ON
```

5. After the power supply is finished ramping to zero, the following screen will be displayed:

```
+0.00 A  -  Magnet in Persistent Mode  
+0.00 Vm  Press PER.SW.CTRL. to exit
```

Operation

Persistent Switch Control : Exiting Persistent Mode

Note

If desired, press the **ESC** key return the Model 430 Programmer to the default display.

```
+0.00 A - Mode: Zero Current
+0.00 Um PSwitch Heater: OFF
```

Note

Refer to section 3.6.2 on page 31 for the procedure to display the magnet current that was established when the persistent switch was cooled.

6. If desired, the power supply system can be de-energized. Turn the power supply off first followed in a few seconds by the Model 430 Programmer.

Note

The Model 430 Programmer will store the state of the magnet in memory and assist the user in exiting the persistent mode when the Model 430 Programmer is next turned on (discussed in the section to follow).

3.13.3 Procedure for Exiting Persistent Mode

To exit the persistent mode of magnet operation, the user should perform the following steps:

1. If the Model 430 Programmer *has not been* powered off since the magnet was placed in persistent mode, *proceed to step 3.*
2. If the Model 430 Programmer *has been* powered off since the magnet was placed in persistent mode, complete the following steps a. and b. before proceeding to step 3.
 - a. Energize the Model 430 and wait for the prompt on the Model 430 display and then energize the power supply.

```
+0.00 A █ Turn on power supply
+0.00 Us Press ENTER to continue
```

After the power supply has been on for a few seconds, press **ENTER** to clear the Model 430 screen prompt.

Operation

Persistent Switch Control : Exiting Persistent Mode

- b. When **ENTER** is pressed, the display will indicate that the magnet was in persistent mode¹ when the Model 430 Programmer was turned off (and display the magnet current that was established when the persistent switch was cooled).

```
Magnet in Persistent Mode (13.5A). Press
PERSIST SWITCH CONTROL to exit Per. Mode
```

3. Press **PERSIST. SWITCH CONTROL** and the Model 430 display prompts with:

```
+0.00 A  P Press ENTER to exit
+0.00 Vs  Persistent Mode
```

Note

*Should the user desire not to exit persistent mode, press **ESC** to return to the default field/current display. If the **PERSIST. SWITCH CONTROL** key is later pressed, the Model 430 Programmer will execute steps 4 through 7, below.*

Note

If persistent mode is not exited and it is later desired to display the magnet current that was established when the persistent switch was cooled, refer to section 3.6.2 on page 31 for the procedure.

4. When **ENTER** is pressed, the power supply is ramped to the current that was flowing in the magnet at the time the persistent mode was entered. The power supply will ramp at the PSw P/S Ramp Rate value².

```
+11.72 A  ↑ Mode: Power Supply ramping
+0.73 Vs  to magnet current
```

1. The **MAGNET IN PERSISTENT MODE** LED will also be illuminated.
2. Refer to section 3.10.2.11 on page 56.

Operation

Persistent Switch Control : Exiting Persistent Mode

5. The persistent switch heater is heated for the preset heating time as set by the PSwitch Heated Time variable¹.

```
+50.00 A  ◊  Mode: Heating Switch (4)
+3.50 Vs   PSwitch Heater: ON
```

Note

The magnet voltage (V_m) is monitored during switch heating. If the voltage is greater than, 0.5 V, the Model 430 Programmer will beep and display a message to indicate a mismatch between the magnet current and power supply current:

```
+50.00 A  ◊  Mode: Heating Switch (4)
+3.50 Vs   *** Current Mismatch ***
```

This mismatch in current indicates the magnet current (and therefore the field) has decayed significantly during the time the magnet was in persistent mode. Since this is not a critical error², after 15 seconds the screen will change back to the default display:

```
+50.00 A  P  Mode: Paused
+3.50 Vs   PSwitch Heater: ON
```

6. After the Model 430 Programmer has completed this persistent switch heating operation, the display reads:

```
+50.00 A  P  Mode: Magnet in Driven Mode
+3.50 Vs   Press ENTER to continue
```

-
1. Refer to section 3.10.2.9 on page 55. The (4) in the display indicates the number of seconds remaining in the heating cycle (4 in this example).
 2. This current mismatch could be indicative of a problem with the magnet persistent joints.

Operation

Persistent Switch Control : Exiting Persistent Mode

7. After **ENTER** is pressed, the default field/current status screen is displayed with the power supply in the pause mode:

```
+50.00 A  P  Mode: Paused
+3.50 Vs  PSwitch Heater: ON
```

3.13.4 Toggling the State of the Persistent Switch Heater

The state of the persistent switch can be toggled by pressing **SHIFT** and then the **PERSIST. SWITCH CONTROL** key. By toggling the state of the heater in this manner, there will be no power supply ramping or other automatic functions.

3.13.4.1 Entering Persistent Mode without altering the power supply current output

1. Place the Model 430 Programmer in the **HOLDING** or **PAUSED** mode at the desired field or current.
2. Press the **SHIFT** and then the **PERSIST. SWITCH CONTROL** key to turn off the persistent switch heater current. Note that the Model 430 Programmer will enter the **COOLING SWITCH** mode and disallow any ramping during the switch cooling period.
3. If magnet current is greater than 100 mA when the switch heater current is turned off, the **MAGNET IN PERSISTENT MODE LED** will illuminate.

3.13.4.2 Exiting Persistent Mode without altering the power supply current output

Caution

To avoid damage to the magnet or triggering protection circuits on the magnet, the current in the power supply should match the current that was flowing in the magnet when the persistent mode was entered.

Note

For the procedure to display the magnet current that was established when the persistent switch was cooled, refer to section 3.6.2 on page 31.

1. Place the Model 430 Programmer in the **HOLDING** or **PAUSED** mode at the desired field or current.

Operation

Ramping Functions Example

2. Press the **SHIFT** and then the **PERSIST. SWITCH CONTROL** key to turn on the persistent switch heater current. Note that the Model 430 Programmer will enter the **HEATING SWITCH** mode and disallow any ramping during the switch heating period.
3. At the end of the switch heating period, the **MAGNET IN PERSISTENT MODE LED** will be turned off and the Model 430 Programmer will be in the **PAUSED** mode.

3.14 Ramping Functions Example

As an example of ramping to two target field/current settings, refer to Figure 3-14 below. Each step is labeled as 1 through 8 in Figure 3-14. The Model 430 Programmer, for the purposes of the example, is assumed to be in the **PAUSED** mode at 0 A at the beginning of the ramping example.

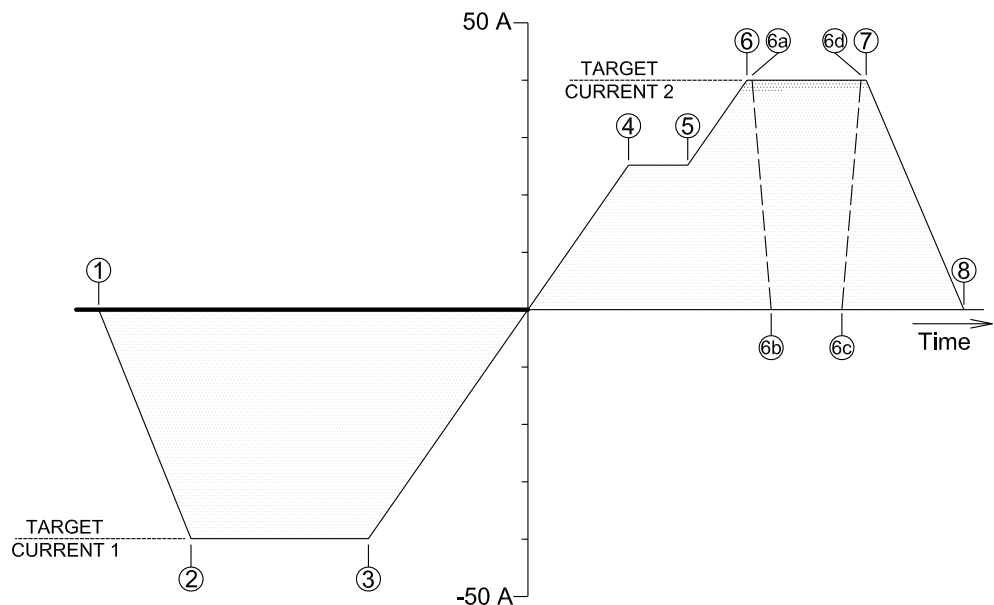

Figure 3-14. Ramping to Two Different Target Field/Current Settings.

Point 1. The current is 0 A and the Model 430 Programmer is in the **PAUSED** mode. The user sets the target field/current to -40.000 A. The **RAMP / PAUSE** key is pressed so that the **PAUSED** mode is no longer active and the Model 430 begins ramping current.

Point 2. The target field/current setting of -40.000 A is achieved and the Model 430 Programmer switches to **HOLDING** mode.

Point 3. The user changes the ramp rate setting. The user also sets a new value of +40.000 A for the target field/current. As soon as the new target

Operation

Quench Detection

field/current is entered, the Model 430 Programmer automatically begins ramping at the specified ramp rate.

Point 4. The user presses the **RAMP / PAUSE** key at a current of 25.15 A and the **PAUSED** mode is activated. The Model 430 Programmer maintains the current in the **PAUSED** mode.

Point 5. The user presses the **RAMP / PAUSE** key once again to resume ramping.

Point 6. The target field/current setting of +40.000 A is achieved and the Model 430 Programmer switches to **HOLDING** mode. At this point the user deactivates the persistent switch heater by pressing the **PERSIST. SWITCH CONTROL** key, which removes the magnet from the circuit.

Point 6a. The dashed line between point 6a and 6b is the rapid ramping down of the power supply current which automatically happens after the PSwitch Cooled Time has elapsed. Note that the magnet current remains at the Point 6 value when the magnet was placed in persistent mode.

Point 6c. The user presses the **PERSIST. SWITCH CONTROL** key which rapidly ramps the power supply output to the current that is flowing in the magnet. The power supply matches the magnet current at point 6d.

Point 7. The user again increases the ramp rate and presses the **RAMP TO ZERO** key to begin ramping to zero current. The Model 430 Programmer automatically ramps the current to 0 A.

Point 8. The Model 430 Programmer switches to **ZERO CURRENT** mode at 0 A current when achieved and holds at this current until further commands are issued by the user.

3.15 Quench Detection

The Model 430 Programmer continuously monitors the superconducting magnet load and can automatically detect a field/current quench condition. If a quench is detected, the **MAGNET QUENCH LED** will be illuminated and the display will appear as shown below. When a quench is detected, the Model 430 automatically sets the power supply output voltage to zero, provides a quench output signal (dry contacts) to the rear panel Quench I/O connector (see page 150 of the *Appendix* for the connector pinout), and will not respond to further input until the **RESET QUENCH SHIFT**-key is

Operation

Quench Detection : External Detection

used to clear the quench detect condition, or until the quench condition is cleared by a remote command.

```
+44.36 A      Quench Detect @ +80.56 A
+0.00 Vs      PSwitch Heater: ON
```

If the **RESET QUENCH** key has been locked¹, the user will be asked to enter the password to clear the quench. The entry of this password will not unlock this reset quench feature, but will only reset the current quench event so operation may resume. Enter the password followed by the **ENTER** key to reset the quench and continue.

```
+44.36 A      Enter Password*
+0.00 Vs      _
```

When the **RESET QUENCH SHIFT**-key is used to clear the quench condition or a remote clear command is issued, the Model 430 Programmer will automatically enter the **PAUSED** mode and will attempt to maintain the current present at the point the quench condition was cleared.

3.15.1 External Quench Detection

The rear panel Quench I/O connector provides pins for external quench input (contact closure — see page 150 of the *Appendix* for the connector pinout). If the quench input is asserted, then the Model 430 Programmer interprets this input as indication of a quench condition and the Model 430 automatically sets the power supply output voltage to zero and will not respond to further input until the **RESET QUENCH SHIFT**-key is used to clear the quench detect condition, or until the quench condition is cleared by a remote command. The rear panel input cannot be disabled; however, it may be left disconnected without the possibility of a generating a false quench condition.

Note

*If the external quench detection circuit continues to assert the quench detection input of the Model 430 Programmer, the **RESET QUENCH SHIFT**-key will be unable to clear the quench condition.*

1. Refer to section 3.10.3.6.8 on page 63.

Operation

Quench Detection : Disabling Internal Detection

3.15.2 Disabling Internal Quench Detection

The internal quench detection feature may be disabled in the Load submenu¹. However, the rear panel Quench I/O connector output remains active.

If the internal quench detection feature is disabled, the Model 430 Programmer attempts to limit the error between the commanded current and the present current to a value that will not result in excessive voltages being introduced across the magnet terminals. Under most operating conditions this will not damage any internal protection circuits of the magnet. If an actual quench condition occurs, the Model 430 will follow the magnet current to zero unless the user intervenes. If the rear panel Quench I/O connector is asserted, the Model 430 will force the power supply output to zero volts regardless of whether the internal quench detection is enabled or disabled.

In the event that the persistent switch becomes normal without user or remote activation of the switch heater control, the Model 430 Programmer will match the magnet current and attempt to stabilize the load *if the internal quench detection feature is disabled*. If the internal quench detection feature is *enabled*, then this event will generally trigger the quench detection logic if a difference exists between the magnet current and the real-time setpoint current of the Model 430.

3.16 External Rampdown

This feature² is useful in any application requiring magnet rampdown in response to an event that can be represented by the closure of a pair of electrical contacts³.

A user input for initiating external rampdown is provided on the rear panel of the Model 430 Programmer. The process is started by shorting, for at least 10 milli-seconds, the input connections through closure of user-supplied external contacts. Once triggered, rampdown of the magnetic field of the magnet is initiated. Operator intervention (such as Ramp/Pause, ESC, etc.) is inhibited until rampdown is completed and the external rampdown signal is cleared.

The external rampdown feature is ideally suited for use with AMI's Model 135 Liquid Helium Level Monitor. The Model 135 has externally accessible normally-open relay contacts that close whenever helium level drops below

-
1. Refer to section 3.10.2.13 on page 57.
 2. When enabled. Refer to section 3.10.2.15 on page 58.
 3. Refer to section A.6.2 on page 151. The contact closure time must be at least 10 milli-seconds to ensure it doesn't fall between the sampling points of the Model 430 Programmer.

Operation

External Rampdown : External Rampdown while in Persistent Mode

a preset level. When appropriately connected to the Model 430 Programmer, these contacts can signal the Model 430 to safely and automatically ramp the magnet field to zero, thereby preventing a magnet quench due to low helium level in the system.

3.16.1 External Rampdown while in Persistent Mode

The following steps and associated screen displays describe the process that occurs after external rampdown is initiated while the magnet is in persistent mode:

1. The Model 430 Programmer first ramps the power supply to the magnet current.

```
+3.92 A  ↑  Mode: Ramping
+0.17 Us  PSwitch Heater: OFF
```

2. Once the power supply is at the magnet current, the **FIELD AT TARGET LED** will light and the unit will momentarily “hold”:

```
+50.00 A  -  Mode: Holding
+2.11 Us  PSwitch Heater: OFF
```

3. Following a short “hold”, the persistent switch will be heated to place the power supply in control of magnet current:

```
+50.00 A  ♦  Mode: Heating Switch (4)
+2.11 Us  PSwitch Heater: ON
```

4. After heating (turning off) the persistent switch, the **MAGNET IN PERSISTENT MODE LED** extinguishes, and rampdown begins. The **FIELD AT TARGET LED** extinguishes.

```
+48.85 A  ↓  Mode: Zeroing Current
+1.89 Us  PSwitch Heater: ON
```

5. After rampdown, the following will display:

```
+0.00 A  -  Ext. Rampdown completed
-0.00 Us  Press ENTER to continue
```

Operation

External Rampdown : External Rampdown while not in Persistent Mode

Note

The external rampdown signal MUST be cleared before pressing ENTER will yield a response. Further operator control is inhibited until the external rampdown signal is cleared.

6. Once the external signal has been cleared, **ENTER** can be pressed. User control will be re-established and the operator can continue manual operation of the system. The following will be displayed after pressing **ENTER**:

```
+0.00 A - Mode: Zero Current
+0.00 Vs PSwitch Heater: ON
```

3.16.2 External Rampdown while not in Persistent Mode

When external rampdown is initiated with the magnet **not** in PERSISTENT mode, the persistent switch is either off or not installed so there is no need for persistent switch heating. The power supply is already at (and in control of) the magnet current, so the Model 430 Programmer executes an ordinary rampdown:

1. The rampdown begins immediately at the ZEROING CURRENT mode described on page 89 (step 4 of section 3.16.1, “External Rampdown while in Persistent Mode”):

```
+48.85 A ↓ Mode: Zeroing Current
+1.89 Vs PSwitch Heater: ON
```

2. The sequence continues as described for the magnet in persistent mode (section 3.16.1, steps 5 through 6).

Note

After rampdown, the external rampdown signal MUST be cleared before continuing. Further operator control is inhibited until the external rampdown signal is cleared.

3.17 Summary of Operational Limits and Default Settings

Table 3-7 provides a summary of the operational limits and the default setting for all Model 430 Programmer parameters. If the user attempts to enter a value outside of the limits, the Model 430 Programmer will beep once and revert to the previous setting.

Operation

Summary of Operational Limits

References to the specifications indicate that the absolute limit is determined by the specific configuration of the Model 430 Programmer purchased.

Table 3-7. Summary of Model 430 Programmer Limits and Defaults

Model 430 Setting (Units)	Absolute Limits	Default Setting ^a
Min Output Voltage (V)	0.000 to -20.000	-6.000
Max Output Voltage (V)	0.001 to +20.000	6.000
Min Output Current (A)	see table on page 8	-125.000
Max Output Current (A)	see table on page 8	125.000
V-V Mode Input Range (V)	-10.000 to +10.000	-10.000 to +10.000
Stability Setting (%)	0.0 to 100.0	0.0
Coil Constant (kG/A)	0.001 to 999.99999	1.0
PSwitch Current (mA)	0.0 to 125.0	10.0
PSwitch Heated Time (sec)	5 to 120	20
PSwitch Cooled Time (sec)	5 to 3600	20
PSwitch Power Supply Ramp Rate (A/sec)	same as min and max ramp (see table on page 8)	10
PSwitch Cooling Gain	0.0 to 100.0	0.0
Magnet Current Rating (A)	+/-0.001 to +/-9999.9999999999	80.000
Current Limit (A)	\geq Min Output Current <i>and</i> \leq Max Output Current	80.000
Display Brightness (%)	25, 50, 75, 100	100
Voltage Limit (V)	\geq 0.001 <i>and</i> \leq Max Output Voltage	2.000
Ramp Rate (A/sec)	see table on page 8	0.100
Target Current (A)	\leq Current Limit	5.000

a. Unless preset by factory.

Operation

Summary of Operational Limits

4 Remote Interface Reference

The Model 430 Programmer provides both RS-232 and Ethernet interfaces as standard features. The serial and Ethernet interfaces may operated simultaneously. Separate output buffers are also provided for the serial and Ethernet return data. However, for optimal performance and simplicity of programming, AMI normally recommends limiting operation to one interface. An exception to this recommendation would be using the serial port as a debugging aid during programming of the Ethernet port (or vice-versa), which can prove to be a useful resource.

4.1 SCPI Command Summary

The following manual conventions are used for SCPI (*Standard Commands for Programmable Instruments*) syntax for the remote interface commands:

- Braces { } enclose valid parameter choices.
- A vertical bar | separates multiple choices for each parameter.
- Triangle brackets < > indicate that you must supply a value.
- Parentheses () within < > indicate alternative units are available.

For example, the command `PSwitch {0|1}` indicates that the command `PSwitch` has two parameter options: 0 or 1. Refer to the detailed description of each command for information regarding specific parameter choices and their meanings. Capitalized portions of the commands indicate acceptable abbreviations. Default settings are shown in bold.

System-Related Commands

(see page 108 for more information)

*IDN?
*RST
*TST?
<Ctrl-C>

SYSTem:LOCal
SYSTem:REMOte
SYSTem:TIME?
SYSTem:TIME:SET <date(mm/dd/yyyy) time(hh:mm:ss)>
SYSTem:ERRor?

Remote Interface Reference

SCPI Command Summary

Status System Commands

(see page 109 for more information)

```
*STB?  
*SRE <enable_value>  
*SRE?  
  
*CLS  
  
*ESR?  
*ESE <enable_value>  
*ESE?  
  
*PSC {0|1}  
*PSC?  
*OPC  
*OPC?
```

SETUP Configuration Commands

(see page 110 for more information)

```
CONFigure:STABility <percent>  
CONFigure:COILconst <value (kG/A, T/A)>  
CONFigure:CURREnt:RATING <current (A)>  
CONFigure:CURREnt:LIMit <current (A)>  
  
CONFigure:PSwitch {0|1}  
CONFigure:PSwitch:CURREnt <current (A)>  
CONFigure:PSwitch:HeatTIME <time (seconds)>  
CONFigure:PSwitch:CoolTIME <time (seconds)>  
CONFigure:PSwitch:CoolingGAIN <percent>  
CONFigure:PSwitch:PowerSupplyRampRate <rate (A/s)>  
  
CONFigure:QUench:DETECT {0|1}  
CONFigure:QUench:RATE <value>  
CONFigure:ABsorber {0|1}  
  
CONFigure:RAMP:RATE:UNITS {0|1}  
CONFigure:FIELD:UNITS {0|1}  
  
CONFigure:IPNAME <system name>
```

Remote Interface Reference

SCPI Command Summary

SETUP Configuration Queries

(see page 110 for more information)

SUPPly:VOLTage:MINimum?
SUPPly:VOLTage:MAXimum?

SUPPly:CURRent:MINimum?
SUPPly:CURRent:MAXimum?

SUPPly:TYPE?
SUPPly:MODE?

STABility?
COILconst?
CURRent:LIMit?
CURRent:RATING?

PSwitch:CURRent?
PSwitch:HeatTIME?
PSwitch:CoolTIME?
PSwitch:PowerSupplyRampRate?
PSwitch:AUTODetect?
PSwitch:CoolingGAIN?
PSwitch:INSTALLED?

QUench:DETECT?
QUench:RATE?
ABsorber?

RAMP:RATE:UNITS?
FIELD:UNITS?

IPNAME?

Protection Configuration Commands

(see page 115 for more information)

CONFigure:LOCK:PSwitch:CONTRol {0|1}
CONFigure:LOCK:TARGet {0|1}
CONFigure:LOCK:RAMP-PAUSE {0|1}
CONFigure:LOCK:RAMPrate {0|1}
CONFigure:LOCK:ZEROfield {0|1}

Remote Interface Reference

SCPI Command Summary

CONFigure:LOCK:RAMPDown {0|1}
CONFigure:LOCK:SUPPLY {0|1}
CONFigure:LOCK:VOLTage:LIMit {0|1}
CONFigure:LOCK:QUench:RESet {0|1}
CONFigure:LOCK:INCR-DECR {0|1}
CONFigure:LOCK:FIELD-CURRENT {0|1}
CONFigure:LOCK:FIELD:UNITS {0|1}
CONFigure:LOCK:STABILITY {0|1}
CONFigure:LOCK:VOLTage:VS-VM {0|1}
CONFigure:LOCK:VOLTMeter {0|1}
CONFigure:LOCK:FINEadjust {0|1}
CONFigure:LOCK:COILconst {0|1}
CONFigure:LOCK:CURRENT:LIMit {0|1}
CONFigure:LOCK:CURRENT:RATING {0:1}
CONFigure:LOCK:PSwitch:SETtings {0|1}
CONFigure:LOCK:QUench:DETECT {0|1}
CONFigure:LOCK:QUench:RATE {0|1}
CONFigure:LOCK:ABSORBER {0|1}
CONFigure:LOCK:BRIGHTness {0|1}
CONFigure:LOCK:NETsetup {0|1}

Protection Configuration Queries

(see page 115 for more information)

LOCK:PSwitch:CONTROL?
LOCK:TARGET?
LOCK:RAMP-PAUSE?
LOCK:ZEROfield?
LOCK:RAMPrate?
LOCK:RAMPDown?
LOCK:SUPPLY?
LOCK:VOLTage:LIMit?
LOCK:QUench:RESet?
LOCK:INCR-DECR?
LOCK:FIELD-CURRENT?
LOCK:FIELD:UNITS?
LOCK:STABILITY?
LOCK:VOLTage:VS-VM?
LOCK:VOLTMeter?
LOCK:FINEadjust?
LOCK:COILconst?
LOCK:CURRENT:LIMit?
LOCK:CURRENT:RATING?
LOCK:PSwitch:SETtings?
LOCK:QUench:DETECT?
LOCK:QUench:RATE?

Remote Interface Reference

SCPI Command Summary

LOCK:ABsorber?

LOCK:BRIGHtness?

LOCK:NETsetup?

Remote Interface Reference

SCPI Command Summary

Ramp Configuration Commands and Queries

(see page 120 for more information)

CONFigure:VOLTage:LIMit *<voltage (V)>*

CONFigure:CURREnt:TARGeT *<current (A)>*

CONFigure:FIELD:TARGeT *<field (kG, T)>*

CONFigure:RAMP:RATE:CURREnt *<segment>,<rate (A/s, A/min)>,
<upper bound (A)>*

CONFigure:RAMP:RATE:FIELD *<segment>,<rate (kG/s, kG/min, T/s,
T/min)>,<upper bound (kG, T)>*

CONFigure:RAMP:RATE:SEGments *<value>*

CONFigure:RAMP:RATE:SEGments *<# segments>*

RAMP:RATE:SEGments?

CONFigure:RAMPDown:ENABLE {0|1}

CONFigure:RAMPDown:RATE:SEGments *<# segments>*

CONFigure:RAMPDown:RATE:CURREnt *<segment> , <rate (A/s, A/
min)> , <upper bound (A)>*

CONFigure:RAMPDown:RATE:FIELD *<segment> , <rate (kG/s, kG/min,
T/s, T/min)> , <upper bound (Kg, T)>*

RAMPDown:ENABLE?

RAMPDown:RATE:SEGments?

RAMPDown:RATE:CURREnt: *<segment>?*

RAMPDown:RATE:FIELD: *<segment>?*

VOLTage:LIMit?

CURREnt:TARGeT?

FIELD:TARGeT?

RAMP:RATE:CURREnt: *<segment>?*

RAMP:RATE:FIELD: *<segment>?*

VOLTage:MAGnet?

VOLTage:SUPPLY?

CURREnt:MAGnet?

CURREnt:SUPPLY?

FIELD:MAGnet?

INDuctance?

Remote Interface Reference

SCPI Command Summary

Ramping State Commands and Queries

(see page 124 for more information)

RAMP
PAUSE
INCR
DECR
ZERO

STATE?

Switch Heater Commands and Queries

(see page 125 for more information)

PSwitch {0|1}
PSwitch?
PERSistent?

Quench State Control and Queries

(see page 126 for more information)

QUench {0|1}
QUench?
Quench:COUNT?

Rampdown State Control and Queries

(see page 126 for more information)

RAMPDownFile?
RAMPDownBackup?
RAMPDown:COUNT?

Trigger Control and Queries

(see page 128 for more information)

Remote Interface Reference

SCPI Introduction

*ETE <enable_value>

*ETE?

*TRG

4.2 Programming Overview

The Model 430 Programmer conforms to the SCPI (*Standard Commands for Programmable Instruments*) IEEE standard. The SCPI standard is an ASCII-based specification designed to provide a consistent command structure for instruments from various manufacturers.

The Model 430 Programmer also implements a status system for monitoring the state of the Model 430 through the *Standard Event* and *Status Byte* registers.

4.2.1 SCPI Language Introduction

SCPI commands conform to a tree structure where commands are grouped according to common keywords. For example, commands which set a Model 430 Programmer setup or operating parameter begin with the keyword CONFigure. The keywords are shown in upper case and lower case to indicate acceptable abbreviations. For the example keyword CONFigure, the user may send either the abbreviated form of CONF, or the entire keyword CONFIGURE. Any other form of the keyword is illegal and will generate an error.

Many commands also require multiple keywords to traverse the tree structure of the entire Model 430 Programmer command set. For example, commands associated with a current setting require the prefix of CONFigure:CURRENT. Note that a colon (:) separates the keywords. No spaces are allowed before or after the colon. Parameters must be separated from the command keyword(s) by at least one space.

4.2.2 SCPI Status System

The Model 430 Programmer status system reports various conditions of the instrument in two registers groups shown in Figure 4-1. The register groups consist of a condition or event register, and an enable register which controls the actions of specific bits within the condition or event registers

A *condition* register continuously monitors the state of the instrument. The bits of a condition register are updated in real time. A condition register is read-only and is not cleared when you read the register. A query of a condition register returns a decimal value in the appropriate output buffer which corresponds to the binary-weighted sum of all bits set in the register.

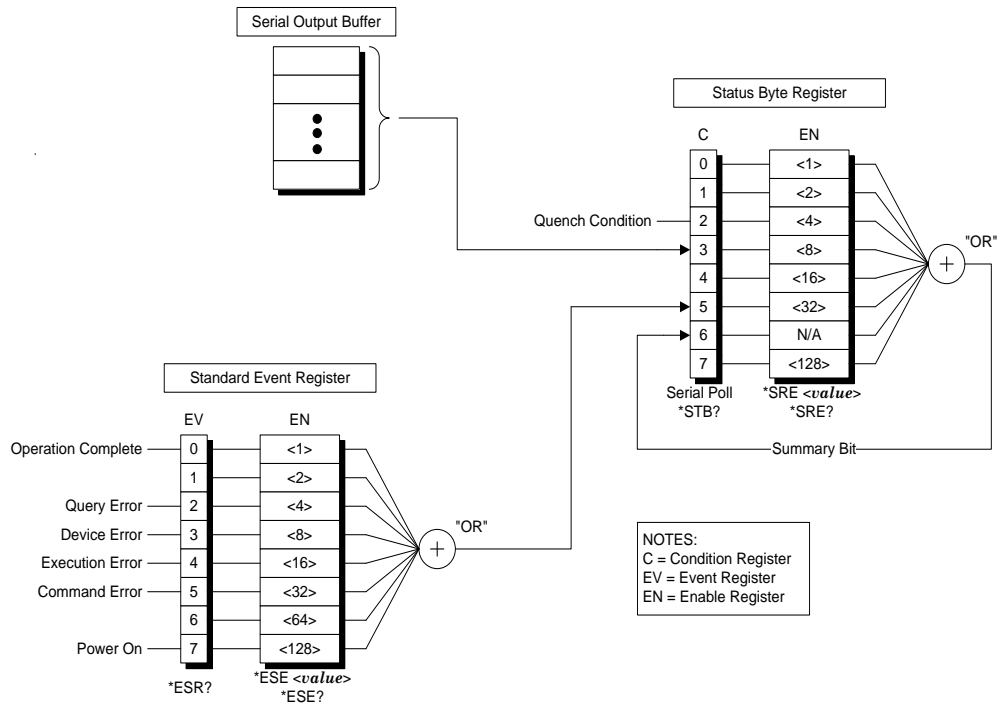

Figure 4-1. The Model 430 Programmer Status System.

An *event* register latches various events. Events are not buffered, therefore once a bit is set in the event register, further occurrences of that event are ignored. Once a bit is set in an event register, the bit remains set until the register is read (*ESR?) or a *CLS (clear status) command is issued. A query of an event register returns a decimal value in the appropriate output buffer which corresponds to the binary-weighted sum of all bits set in the register.

An *enable* register (or bitmask) defines which bits in an event register are reported to the Status Byte register group. An enable register can be both written and queried. The *CLS (clear status) command does not clear an enable register. To enable or disable bits in an enable register, write a decimal value which corresponds to the binary-weighted sum of the bits you wish reported to the Status Byte register.

4.2.2.1 Status Byte Register

The Status Byte register group reports conditions from the Standard Event register or output buffers. Data in the output buffer is immediately reported in the "Serial Message Available" bit (bit 3). Clearing a bit in the Standard Event register will update the corresponding bit in the Status Byte register, according to the Standard Event enable register. Reading the pending

Remote Interface Reference

SCPI Status System

messages in the output buffers will clear the appropriate “Message Available” bit. The bit definitions for the Status Byte register are defined in Table 4-1.

Table 4-1. Bit Definitions for the Status Byte Register

Bit Number	Decimal Value	Definition
0 <i>Not Used</i>	1	Always “0”.
1 <i>Not Used</i>	2	Always “0”.
2 Quench Condition	4	The Model 430 has detected a quench.
3 Serial Message Available	8	The serial output buffer contains unread data.
4 <i>Not Used</i>	16	Always “0”.
5 Standard Event	32	One or more enabled bits are set in the Standard Event register.
6 Status Byte Summary	64	One or more enabled bits are set in the Status Byte register.
7 <i>Not Used</i>	128	Always “0”.

Bit 2 of the Status Byte register, indicating a quench condition, remains set until the quench condition is cleared via the front panel or by remote command. Bits 3 and 4 remain set until all data has been read from the respective output buffer.

The Status Byte *condition register* is cleared when:

- A *CLS command is executed.
- The Standard Event register is read (only bit 5 of the Status Byte register is cleared).
- The indicated condition no longer exists.

The Status Byte *enable register* is cleared when:

- The *SRE 0 command is executed.
- The power is turned off and then back on, and the Model 430 Programmer was configured for *PSC 1 (power-on status clear). The enable register setting is persistent if the Model 430 Programmer is configured for *PSC 0 (no status clear on power-on).

4.2.2.2 Reading the Status Byte using *STB?

The *STB? returns the contents of the Status Byte register, but it is processed in the command queue like any other command. The *STB? command does not clear bit 6 of the Status Byte register.

4.2.2.3 Using the Message Available Bit(s)

The “Message Available” bits (bits 3 or 4) of the Status Byte register can be used to determine when data is available to read into your host computer. The Model 430 Programmer clears the “Message Available” bits only after all data has been read from the output buffer(s).

The “Message Available” bits of the Status Byte register are useful for determining if *queries* have executed; however, they are not useful alone for determining if *commands* have completed execution, since commands do not provide return data.

4.2.3 Standard Event Register

The Standard Event register group reports a power-on condition, various error conditions, and indicates when an operation has completed. Any or all of the Standard Events can be reported to the Status Byte register by enabling the corresponding bit(s) in the Standard Event enable register (see Figure 4-1). To set the Standard Event enable register, write a binary-weighted decimal value using the *ESE <value> command.

The bit definitions for the Standard Event register are provided in Table 4-2. To query the Model 430 Programmer for the details of a reported error in the Standard Event register, use the SYSTem:ERRor? query. See section 4.6 for a complete discussion of the error buffer and messages.

The Standard Event *register* is cleared when:

- The *CLS (clear status) command is executed.
- The Standard Event register is queried using the *ESR? command.

The Standard Event *enable register* is cleared when:

- The *ESE 0 command is executed.
- The power is turned off and then back on, and the Model 430 Programmer was configured for *PSC 1 (power-on status clear). The

Remote Interface Reference

Command Handshaking

enable register setting is persistent if the Model 430 Programmer is configured for *PSC 0 (no status clear on power-on).

Table 4-2. Bit Definitions for the Standard Event Register

Bit Number	Decimal Value	Definition
0 Operation Complete	1	All commands prior to and including *OPC have been executed.
1 <i>Not Used</i>	2	Always "0".
2 Query Error	4	A query error occurred. See the error messages in the -200 range.
3 Device Error	8	A device error occurred. See the error messages in the -400 range.
4 Execution Error	16	An execution error occurred. See the error messages in the -300 range.
5 Command Error	32	A command error occurred. See the error messages in the -100 range.
6 <i>Not Used</i>	64	Always "0".
7 Power On	128	Power has been cycled since the last time the Standard Event register was read or cleared.

4.2.4 Command Handshaking

The Model 430 Programmer provides an internal command queue that can store up to 4 commands or queries. However, it is possible that the host computer can overwhelm the command queue by sending commands faster than the Model 430 can execute. If the Model 430 Programmer cannot process a command due to a full command queue, the command is ignored and the -303, "Input overflow" error is reported.

Handshaking is generally not a concern unless more than 4 *commands* are sent sequentially. If a *query* is sent, the user will normally wait for return data for the queries before proceeding to send the next query or command. In the case of sending numerous *commands* in sequence, there are two methods available to help prevent command queue overflows which are discussed below.

4.2.4.1 Using the *OPC Command

The *OPC command is executed within the normal command queue. Upon completed execution of the *OPC command, the "Operation Complete" bit (bit 0) of the Standard Event register will be set. This command is useful

Remote Interface Reference

Command Handshaking

should many commands be sent to the Model 430 Programmer in rapid succession.

An example of a sequence of commands using the *OPC command to handshake is the following:

```
CONF:CURR:TARG 50.0;  
CONF:RAMP:RATE:CURR 1, 0.1, 80.0;  
CONF:VOLT:LIM 5.0;  
*OPC;
```

The above example sets the target current to 50.0 A, the ramp rate to 0.1 A/s, the Voltage Limit to 5.0 V, and sends as the fourth command the *OPC command for determining when execution all of the commands (including *OPC) is completed. The *OPC? query is used to query completion of all three commands.

4.2.4.2 Using the *OPC? Query

The *OPC? query is similar to the *OPC command, but instead of setting the “Operation Complete” bit of the Standard Event register, the *OPC? query returns a “1” (plus termination characters) to the appropriate output buffer when executed. Using *OPC? is a simple solution for determining completed command execution. It is also unambiguous during simultaneous serial and Ethernet operation since the result is returned directly to the requesting communication interface.

4.3 RS-232 Configuration

The Model 430 Programmer uses the following parameters related to the RS-232 interface:

- *Baud Rate*: 115200
- *Parity*: No Parity
- *Data Bits*: 8 Data Bits
- *Number of Start Bits*: 1 bit
- *Number of Stop Bits*: 1 bit
- *Flow Control*: Hardware (RTS/CTS)

4.3.1 Serial Connector

An IBM-compatible computer's serial port can be directly connected to the Model 430 Programmer via a standard DB9-female-to-DB9-female null modem serial cable. Refer to your computer's documentation to determine which serial ports are available on your computer and the required connector type.

The Model 430 Programmer is classified as a DTE (Data Terminal Equipment) device. It uses the standard DB9 male connector and identical pinout used on IBM-compatible computers. The RS-232 connector pinout for the Model 430 Programmer is fully documented on page 154 in the *Appendix*.

4.3.2 Termination Characters

All commands and queries are transmitted and received as ASCII values and are case insensitive. The Model 430 Programmer always transmits `<CR><LF>` (a *carriage return* followed by a *linefeed*) at the end of an RS-232 transmission. The Model 430 Programmer can accept `<CR>`, `<LF>`, `<CR><LF>`, or `<LF><CR>`, or a semicolon (;) as termination characters from an external computer.

4.4 Ethernet Configuration

The Model 430 Programmer provides a 10/100Base-T Ethernet interface as a standard feature. It complies with the IEEE 802.3u 100Base-TX and 802.3 10Base-T standards.

The Model 430 Programmer allows its IP address, subnet mask and gateway IP address to be assigned either statically or dynamically. To make these values static and assign them manually, set IP Address Assignment to Static (see section 3.10.5.1) and then set the values using

Remote Interface Reference

IEEE-488 Configuration

the parameters under the Net Setup submenu (see sections 3.10.5.2, 3.10.5.3 and 3.10.5.4). To make the values dynamically assigned by a network DHCP server, set IP Address Assignment to DHCP (see section 3.10.5.1).

The system name (also known as *host name* or *computer name*), can be set using remote communications (either Ethernet or RS-232); it cannot be edited using the front panel keypad.

All network parameters (even those assigned by a DHCP server) can be viewed using the Net Settings submenu (see section 3.10.4).

4.4.1 Ethernet Connector

The Model 430 Programmer uses a standard RJ-45 jack for Ethernet communications. The Ethernet jack pinout is fully documented in Table A-8 on page 154 in the *Appendix*.

4.4.2 Termination Characters

All commands and queries are transmitted and received as ASCII values and are case insensitive. The Model 430 Programmer always transmits `<CR><LF>` (a *carriage return* followed by a *linefeed*) at the end of an Ethernet transmission. The Model 430 can accept `<CR>`, `<LF>`, `<CR><LF>`, or `<LF><CR>`, or a semicolon (;) as termination characters from an external computer.

Remote Interface Reference

System-Related Commands

4.5 Command Reference

The following paragraphs present all Model 430 Programmer commands and queries in related groups and a detailed description of the function of each command or query is provided. Examples are also provided where appropriate. Return strings may be up to 80 characters in length.

4.5.1 System-Related Commands

- *IDN?

Return the identification string of the Model 430 Programmer. The identification string contains the AMI model number and firmware revision code.

- *RST

Resets the Model 430 Programmer. This is equivalent to cycling the power to the Model 430 Programmer using the power switch. All non-volatile calibration data and battery-backed memory is restored. Status is cleared according to the *PSC setting.

- *TST?

Performs a self-test. Currently always returns “1”.

- <Ctrl-C>

This clears the output buffers of the Model 430 Programmer and prepares the instrument for a new command. Status registers are unaffected. <Ctrl-C> corresponds to ASCII code 03.

- SYSTem:LOCa1

Enables all front panel controls. All front panels controls are enabled by default after a power-up or *RST command.

- SYSTem:REMOte

Note

*The SYSTem:REMOte command only disables the front panel controls for purposes of preventing accidental operation of a front panel feature. It is **not** necessary for this command to be sent prior to using a remote interface. Send the SYSTem:LOCa1 command, send the *RST command, press **SHIFT** followed by **MENU**, or cycle Model 430 Programmer power to re-enable the front panel controls.*

Disables all front panel controls. If the Model 430 Programmer is in the remote mode, an asterisk (*) will appear in the front panel display in the position just below the ramping character as shown below.

Remote Interface Reference

Status System Commands

```
+50.00 kG ↑ Status: Ramping  
+1.50 Us * PSwitch Heater: ON
```

Figure 4-2. Asterisk Indicating Model 430 in Remote Mode

- SYSTem:TIME?

Returns the date and time of the Model 430 Programmer in the format *mm/dd/yyyy hh:mm:ss*. Time is always reported in 24-hour format.

- SYSTem:TIME:SET <date(mm/dd/yyyy) time(hh:mm:ss)>

Sets the date and time of the Model 430 Programmer using the format *mm/dd/yyyy hh:mm:ss*. Time is always set in 24-hour format.

- SYSTem:ERRor?

Queries the error buffer of the Model 430 Programmer. Up to 10 errors are stored in the error buffer. Errors are retrieved in first-in-first-out (FIFO) order. The error buffer is cleared by the *CLS (clear status) command or when the power is cycled. Errors are also cleared as they are read. See page 130 for a complete description of the error buffer and messages.

4.5.2 Status System Commands

The status system register groups and commands are illustrated in Figure 4-1 on page 101.

- *STB?

Returns the contents of the Status Byte register. The *STB? command does not clear the “Summary Bit” (bit 6) of the Status Byte register.

- *SRE <enable_value>

Enables bits in the Status Byte register to be reported in the “Summary Bit” (bit 6) of the Status Byte register. To enable bits, you must write a decimal <enable_value> which corresponds to the binary-weighted sum of the bits you wish to enable. Refer to Table 4-1 on page 102 for more information. For example, to enable quench detections only in the “Summary Bit” of the Status Byte register, send the command:

```
*SRE 4;
```

- *SRE?

The *SRE? query returns a decimal sum which corresponds to the binary-weighted sum of the bits enabled by the last *SRE command.

- *CLS

Clears the Standard Event register and the error buffer.

- *ESR?

Returns a decimal sum which corresponds to the binary-weighted sum of the contents of the Standard Event register.

- *ESE *<enable_value>*

Enables bits in the Standard Event register to be reported in the “Standard Event” bit (bit 5) of the Status Byte register. To enable bits, you must write a decimal *<enable_value>* which corresponds to the binary-weighted sum of the bits you wish to enable. Refer to Table 4-2 on page 104 for more information. For example, to enable *all* categories of error messages to be reported in bit 5 of the Status Byte register, send:

```
*ESE 60;
```

- *ESE?

The *ESE? query returns a decimal sum which corresponds to the binary-weighted sum of the bits enabled by the last *ESE command.

- *PSC {0|1}

Power-On Status Clear. If *PSC 1 is in effect, the Standard Event enable register and the Status Byte enable register are cleared at power on. If *PSC 0 is in effect, the enable registers are not cleared at power on. The default setting is “1”.

- *PSC?

Returns the *Power-On Status Clear* setting currently in effect. A value of “0” indicates the enable registers are not cleared at power on; a value of “1” indicates the enable registers are cleared at power on.

- *OPC

Sets the “Operation Complete” bit (bit 0) of the Standard Event register when executed. See page 104 for a complete discussion.

- *OPC?

Returns “1” to the requesting interface when executed. See page 105 for more information.

4.5.3 SETUP Configuration Commands and Queries

The SETUP Configuration Commands and Queries provide read/write access to the setup functions available within the Supply (see section 3.10.1), Load (see section 3.10.2), and Misc (see section 3.10.3) submenus.

Remote Interface Reference

SETUP Configuration Commands and Queries

- SUPPLY:TYPE?

Returns the index according to the table below for the selected power supply type according to the table below. This value can be configured only via front panel operation of the SUPPLY setup menu.

Table 4-3. Return Values and Meanings for SUPPLY:TYPE? Query

Return Value	Meaning
0	AMI 12100PS
1	AMI 12200PS
2	AMI 4Q05100PS
3	AMI 4Q06125PS
4	AMI 4Q06250PS
5	AMI 4Q12125PS
6	AMI 10100PS
7	AMI 10200PS
8	HP 6260B
9	Kepeco BOP 20-5M
10	Kepeco BOP 20-10M
11	Xantrex XFR 7.5-140
12	Custom
13	AMI Model 05100PS-430-601
14	AMI Model 05200PS-430-601
15	AMI Model 05300PS-430-601
16	AMI Model 05400PS-430-601
17	AMI Model 05500PS-430-601

- SUPPLY:VOLTage:MINimum?

Returns the minimum *power supply* compliance setting in volts. This value can be configured only via front panel operation using the Supply submenu and is set automatically when a preset supply type is selected.

- SUPPLY:VOLTage:MAXimum?

Returns the maximum *power supply* compliance in volts. This value can be configured only via front panel operation using the Supply submenu and is set automatically when a preset supply type is selected.

- SUPPLY:CURRENT:MINimum?

Returns the minimum output current capacity of the *power supply* in amperes. This value can be configured only via front panel operation using the Supply submenu and is set automatically when a preset supply type is selected.

- SUPPLY:CURRENT:MAXimum?

Returns the maximum output current capacity of the *power supply* in amperes. This value can be configured only via front panel operation using the Supply submenu and is set automatically when a preset supply type is selected.

- SUPPLY:MODE?

Returns an integer value corresponding to the voltage output mode according to the table below:

Table 4-4. Return Values and Meanings for SUPPLY:MODE? Query

Return Value	Meaning
0	+0.000 to +5.000
1	+0.000 to +10.000
2	-5.000 to +5.000
3	-10.000 to +10.000
4	+0.000 to -5.000
5	+0.000 to +8.000

This value can be configured only via front panel operation using the Supply submenu and is set automatically when a preset supply type is selected.

- CONFIGure:STABility <percent>

Sets the stability setting in percent.

- STABility?

Returns the stability setting in percent.

- CONFIGure:COILconst <value (kG/A, T/A)>

Sets the coil constant (also referred to as the field-to-current ratio) per the selected field units. The coil constant must be set to a non-zero, positive value in order to command or query the Model 430 Programmer in units of field.

Remote Interface Reference

SETUP Configuration Commands and Queries

- COILconst?

Returns the coil constant setting in kG/A or T/A per the selected field units.

- CONFigure:CURRENT:LIMit <*current (A)*>

Sets the Current Limit in amperes. The Current Limit is the largest magnitude operating current allowed during any ramping mode. For four-quadrant power supplies, the Current Limit functions as both a positive and negative current limit.

- CURRENT:LIMit?

Returns the Current Limit in amperes.

- CONFigure:CURRENT:RATING <*current (A)*>

Sets the magnet current rating in amperes.

- CURRENT:RATING?

Returns the current magnet rating in amperes.

- CONFigure:PSwitch {0|1}

- PSwitch:INSTalled?

“0” indicates that a persistent switch is not installed on the connected superconducting magnet. “1” indicates that a persistent switch is installed. If a persistent switch is installed, the persistent switch heated current and time should be specified. The default value is “1”.

- CONFigure:PSwitch:CURRENT <*current (mA)*>

Sets the persistent switch heater current in mA.

- PSwitch:AUTODetect?

Executes the auto-detection algorithm (Refer to section 3.10.2.7 on page 54) and returns the appropriate persistent switch heater current in mA. Note that after this value is returned, it can be entered into the Model 430 Programmer using the CONFigure:PSwitch:CURRENT command.

- PSwitch:CURRENT?

Returns the persistent switch heater current setting in mA.

- CONFigure:PSwitch:HeatTIME <*time (seconds)*>

Sets the time required in seconds for the persistent switch to become resistive after the persistent switch heater has been activated.

- PSwitch:HeatTIME?

Returns the persistent switch heated time in seconds.

- `CONFigure:PSwitch:CoolTIME <time (seconds)>`

Sets the time required in seconds for the persistent switch to become superconducting after the persistent switch heater has been deactivated.

- `CONFigure:PSwitch:PowerSupplyRampRate <rate (A/s)>`

Sets the ramp rate that will be used by the power supply to ramp the current¹ during the **PERSIST. SWITCH CONTROL** operation. For more information as to how this **PERSIST. SWITCH CONTROL** function operates, refer to section 3.6.1 on page 29.

- `PSwitch:CoolTIME?`

Returns the persistent switch cooled time in seconds.

- `PSwitch:PowerSupplyRampRate?`

Returns the power supply ramp rate used to change the power supply output when the magnet persistent switch is cool. The units are A/sec.

- `CONFigure:PSwitch:CoolingGAIN <percent>`

Sets the persistent switch cooling gain in percent.

- `PSwitch:CoolingGAIN?`

Returns the persistent switch cooling gain in percent.

- `CONFigure:QUench:DETect {0|1}`

Sending “0” disables the automatic quench detection function of the Model 430 Programmer. “1” enables the automatic quench detection function of the Model 430. See section 3.15 for more information. “0” is the default value.

- `QUench:DETect?`

Returns “0” indicating automatic quench detection is disabled, or “1” indicating that the automatic quench detection is enabled.

- `CONFigure:QUench:RATE <value>`

Sets the value of the quench detect rate variable. Allowable values are from “0.1” to “2.0”. “1.5” is the default value (no units).

- `QUench:RATE?`

Returns the value of the quench detect rate variable (no units).

- `CONFigure:ABsorber {0|1}`

Sending “0” indicates that an energy absorber is not present in the system. A “1” indicates that an energy absorber is present. “0” is the default value.

1. While the magnet is in persistent mode.

Remote Interface Reference

SETUP Configuration Commands and Queries

- ABSorber?

Returns “0” indicating that an energy absorber is not present in the system, or “1” indicating that an energy absorber is present.

- CONFigure:RAMP:RATE:UNITS {0|1}

Sets the preferred ramp rate time units. Sending “0” selects seconds. A “1” selects minutes. “0” is the default value. The selected units are applied to both the Model 430 Programmer display and the appropriate remote commands.

- RAMP:RATE:UNITS?

Returns “0” for ramp rates displayed/specified in terms of seconds, or “1” for minutes.

- CONFigure:FIELD:UNITS {0|1}

Sets the preferred field units. Sending “0” selects kilogauss. A “1” selects tesla. “0” is the default value. The selected field units are applied to both the Model 430 Programmer display and the applicable remote commands.

- FIELD:UNITS?

Returns “0” for field values displayed/specified in terms of kilogauss, or “1” for tesla.

- CONFigure:IPNAME <system name>

Sets the system name (also known as *host name* or *computer name*), the *name* by which the Model 430 Programmer is identified on a network.

Note

If the system name value is changed, the Model 430 Programmer power must be cycled off for at least 5 seconds and then back on to complete the change. The new value will be used internally immediately (even before cycling power off and back on), but the IPNAME? query will return the previous system name until the Model 430 Programmer is restarted.

- IPNAME?

Returns the system name (also known as *host name* or *computer name*).

4.5.4 Protection Commands and Queries

The Protection Commands and Queries provide read/write access to all protection settings which can be accessed under the Settings Protection submenu. See section 3.10.3.6 for more information regarding the settings protection features of the Model 430 Programmer.

Remote Interface Reference

SETUP Configuration Commands and Queries

- `CONFigure:LOCK:PSwitch:CONTRol {0|1}`

Specifies whether use of the **PERSIST. SWITCH CONTROL** key is locked or unlocked. Sending “0” unlocks. A “1” locks. “0” is the default value.

- `LOCK:PSwitch:CONTRol?`

Returns “0” for use of the **PERSIST. SWITCH CONTROL** key unlocked, or “1” for locked.

- `CONFigure:LOCK:TARGet {0|1}`

Specifies whether use of the **TARGET FIELD SETPOINT** key is locked or unlocked. Sending “0” unlocks. A “1” locks. “0” is the default value.

- `LOCK:TARGet?`

Returns “0” for use of the **TARGET FIELD SETPOINT** key unlocked, or “1” for locked.

- `CONFigure:LOCK:RAMP-PAUSE {0|1}`

Specifies whether use of the **RAMP / PAUSE** key is locked or unlocked. Sending “0” unlocks. A “1” locks. “0” is the default value.

- `LOCK:RAMP-PAUSE?`

Returns “0” for use of the **RAMP / PAUSE** key unlocked, or “1” for locked.

- `CONFigure:LOCK:ZEROfield {0|1}`

Specifies whether use of the **RAMP TO ZERO** key is locked or unlocked. Sending “0” unlocks. A “1” locks. “0” is the default value.

- `LOCK:ZEROfield?`

Returns “0” for use of the **RAMP TO ZERO** key unlocked, or “1” for locked.

- `CONFigure:LOCK:RAMPrate {0|1}`

Specifies whether ramp rate settings are locked or unlocked. Ramp rate settings protected by this setting are: use of the **RAMP RATE SHIFT**-key menu, editing of the Ramp Segments value (under the Misc submenu) and editing of the Ramp Time Units value (under the Misc submenu). Sending “0” unlocks. A “1” locks. “0” is the default value.

- `LOCK:RAMPrate?`

Returns “0” for ramp rate settings unlocked, or “1” for locked.

- `CONFigure:LOCK:SUPPLY {0|1}`

Specifies whether the Select Supply picklist value is locked or unlocked. If the Select Supply value is Custom..., then setting Power Supply Lock to Locked also prevents the custom power supply parameters (Min Output Voltage, Max Output Voltage, Min Output Current, Max Output Current

Remote Interface Reference

SETUP Configuration Commands and Queries

and V-V Mode Input Range) from being edited. Sending “0” unlocks. A “1” locks. “0” is the default value.

- `LOCK:SUPPLY?`

Returns “0” for Select Supply picklist value unlocked, or “1” for locked.

- `CONFigure:LOCK:VOLTage:LIMit {0|1}`

Specifies whether use of the **VOLTAGE LIMIT SHIFT**-key menu is locked or unlocked. Sending “0” unlocks. A “1” locks. “0” is the default value.

- `LOCK:VOLTage:LIMit?`

Returns “0” for use of the **VOLTAGE LIMIT SHIFT**-key menu unlocked, or “1” for locked.

- `CONFigure:LOCK:QUench:RESet {0|1}`

Specifies whether use of the **RESET QUENCH SHIFT**-key command is locked or unlocked. Sending “0” unlocks. A “1” locks. “0” is the default value.

- `LOCK:QUench:RESet?`

Returns “0” for use of the **RESET QUENCH SHIFT**-key command unlocked, or “1” for locked.

- `CONFigure:LOCK:QUench:RATE {0|1}`

Specifies whether use of the quench rate command is locked or unlocked. Sending “0” unlocks. A “1” locks. “0” is the default value.

- `LOCK:QUench:RATE?`

Returns “0” for use of the quench rate command unlocked, or “1” for locked.

- `CONFigure:LOCK:INCR-DECR {0|1}`

Specifies whether use of the **INCR. FIELD** and **DECR. FIELD SHIFT**-key commands is locked or unlocked. Sending “0” unlocks. A “1” locks. “0” is the default value.

- `LOCK:INCR-DECR?`

Returns “0” for use of the **INCR. FIELD** and **DECR. FIELD SHIFT**-key commands unlocked, or “1” for locked.

- `CONFigure:LOCK:FIELD-CURRENT {0|1}`

Specifies whether use of the **FIELD <> CURRENT SHIFT**-key command is locked or unlocked. Sending “0” unlocks. A “1” locks. “0” is the default value.

Remote Interface Reference

SETUP Configuration Commands and Queries

- `LOCK:FIELD-CURRENT?`

Returns “0” for use of the **FIELD <> CURRENT SHIFT**-key command unlocked, or “1” for locked.

- `CONFigure:LOCK:FIELD:UNITS {0|1}`

Specifies whether the Field Units value is locked or unlocked (whether accessed through the **FIELD UNITS SHIFT**-key menu or under the Misc submenu). Sending “0” unlocks. A “1” locks. “0” is the default value.

- `LOCK:FIELD:UNITS?`

Returns “0” for Field Units value unlocked, or “1” for locked.

- `CONFigure:LOCK:STABILITY {0|1}`

Specifies whether the Stability Setting value is locked or unlocked (whether accessed through the **STAB. SHIFT**-key menu or under the Load submenu). Sending “0” unlocks. A “1” locks. “0” is the default value.

- `LOCK:STABILITY?`

Returns “0” for Stability Setting value unlocked, or “1” for locked.

- `CONFigure:LOCK:VOLTage:VS-VM {0|1}`

Specifies whether use of the **Vs <> Vm SHIFT**-key command is locked or unlocked. Sending “0” unlocks. A “1” locks. “0” is the default value.

- `LOCK:VOLTage:VS-VM?`

Returns “0” for use of the **Vs <> Vm SHIFT**-key command unlocked, or “1” for locked.

- `CONFigure:LOCK:VOLTMeter {0|1}`

Specifies whether use of the **VOLT METER SHIFT**-key command is locked or unlocked. Sending “0” unlocks. A “1” locks. “0” is the default value.

- `LOCK:VOLTage:VOLTMeter?`

Returns “0” for use of the **VOLT METER SHIFT**-key command unlocked, or “1” for locked.

- `CONFigure:LOCK:FINEadjust {0|1}`

Specifies whether use of the **FINE ADJUST SHIFT**-key command is locked or unlocked. Sending “0” unlocks. A “1” locks. “0” is the default value.

- `LOCK:VOLTage:FINEadjust?`

Returns “0” for use of the **FINE ADJUST SHIFT**-key command unlocked, or “1” for locked.

Remote Interface Reference

SETUP Configuration Commands and Queries

- `CONFigure:LOCK:COILconst {0|1}`

Specifies whether the Coil Constant value (under the Load submenu) is locked or unlocked. Sending “0” unlocks. A “1” locks. “0” is the default value.

- `LOCK:VOLTage:COILconst?`

Returns “0” for Coil Constant value (under the Load submenu) unlocked, or “1” for locked.

- `CONFigure:LOCK:CURRent:LIMit {0|1}`

Specifies whether the Current Limit value (under the Load submenu) is locked or unlocked. Sending “0” unlocks. A “1” locks. “0” is the default value.

- `LOCK:CURRent:LIMit?`

Returns “0” for Current Limit value (under the Load submenu) unlocked, or “1” for locked.

- `CONFigure:LOCK:PSwitch:SETtings {0|1}`

Specifies whether persistent switch settings are locked or unlocked. Persistent switch settings protected by this setting (all under the Load submenu) are: the PSwitch Installed picklist value, the PSwitch Current value, the PSwitch Heated Time value, PSwitch Current Detect, PSwitch Cooled time, Psw P/S Ramp Rate, and PSwitch Cooling Gain. Sending “0” unlocks. A “1” locks. “0” is the default value.

- `LOCK:PSwitch:SETtings?`

Returns “0” for persistent switch settings unlocked, or “1” for locked.

- `CONFigure:LOCK:QUench:DETECT {0|1}`

Specifies whether the Enable Quench Detect picklist value (under the Load submenu) is locked or unlocked. Sending “0” unlocks. A “1” locks. “0” is the default value.

- `LOCK:QUench:DETECT?`

Returns “0” for Enable Quench Detect picklist value (under the Load submenu) unlocked, or “1” for locked.

- `CONFigure:LOCK:ABsorber {0|1}`

Specifies whether the Energy Absorber Present picklist value (under the Load submenu) is locked or unlocked. Sending “0” unlocks. A “1” locks. “0” is the default value.

Remote Interface Reference

Ramp Configuration Commands and Queries

- LOCK:ABsorber?

Returns “0” for Energy Absorber Present picklist value (under the Load submenu) unlocked, or “1” for locked.

- CONFigure:LOCK:BRIGHtness {0|1}

Specifies whether the Display Brightness picklist value (under the Misc submenu) is locked or unlocked. Sending “0” unlocks. A “1” locks. “0” is the default value.

- LOCK:BRIGHtness?

Returns “0” for Display Brightness picklist value (under the Misc submenu) unlocked, or “1” for locked.

- CONFigure:LOCK:NETsetup {0|1}

Specifies whether the Net Setup submenu is locked or unlocked. Sending “0” unlocks. A “1” locks. “0” is the default value.

- LOCK:NETsetup?

Returns “0” for Net Setup submenu unlocked, or “1” for locked.

- CONFigure:LOCK:CURREnt:RATING {0|1}

Specifies whether the Magnet Current Rating picklist value (under the LOAD submenu) is locked or unlocked. Sending “0” unlocks. A “1” locks. “0” is the default value.

- LOCK:CURREnt:RATING?

Returns “0” for Magnet Current Rating picklist value (under the LOAD submenu) unlocked, or “1” for locked.

- CONFigure:LOCK:RAMPDown {0|1}

Specifies whether the External Rampdown Enabled picklist value (under the LOAD submenu) is locked or unlocked. Sending “0” unlocks. A “1” locks. “0” is the default value.

- LOCK:RAMPDown?

Returns “0” for External Rampdown Enabled picklist value (under the LOAD submenu) unlocked, or “1” for locked.

4.5.5 Ramp Configuration Commands and Queries

The ramp configuration commands set the various parameters required for defining piecewise-linear ramp segments. The external rampdown function also has the ramp segmenting capability. The function operates in a manner similar to the normal ramp as described in section 3.7.1 on page 33, but parameters can only be edited via the remote interface. See

Remote Interface Reference

Ramp Configuration Commands and Queries

section 3.12 for additional information on determining ramp rates. Also included are queries for collecting the magnet field, current, voltage, and inductance.

- `CONFigure:VOLTage:LIMit <voltage (V)>`

Sets the ramping Voltage Limit in volts. The ramping Voltage Limit may not exceed the maximum output voltage of the power supply.

- `VOLTage:LIMit?`

Returns the ramping Voltage Limit in volts.

- `CONFigure:CURREnt:TARGet <current (A)>`

Sets the target current in amperes.

- `CURREnt:TARGet?`

Returns the target current setting in amperes.

- `CONFigure:FIELD:TARGet <field (kG, T)>`

Sets the target field in units of kilogauss or tesla, per the selected field units. This command requires that a coil constant be defined, otherwise an error is generated.

- `FIELD:TARGet?`

Returns the target field setting in units of kilogauss or tesla, per the selected field units. This query requires that a coil constant be defined, otherwise an error is generated.

- `CONFigure:RAMP:RATE:SEGments <value>`

Sets the number of ramp segments (see section 3.7.1 for details of the use of ramp segments).

- `RAMP:RATE:SEGments?`

Returns the number of ramp segments.

- `CONFigure:RAMP:RATE:CURREnt <segment>,<rate (A/s, A/min)>,<upper bound (A)>`

Sets the ramp rate for the specified segment (values of 1 through the defined number of ramp segments are valid) in units of A/sec or A/min (per the selected ramp rate units), and defines the current upper bound for that segment in amperes (see section 3.7.1 for details of the use of ramp segments).

- `RAMP:RATE:CURREnt:<segment>?`

Returns the ramp rate setting for the specified segment (values of 1 through the defined number of ramp segments are valid) in units of A/sec

Remote Interface Reference

Ramp Configuration Commands and Queries

or A/min (per the selected ramp rate units) and the current upper bound for that range in amperes. The two return values are separated by a comma. For example:

```
RAMP:RATE:CURRENT:1?  
0.1000,50.0000
```

- **CONFigure:RAMP:RATE:FIELD** *<segment>*,*<rate (kG/s, kG/min, T/s, T/min)>*,*<upper bound (kG, T)>*

Sets the ramp rate for the specified segment (values of 1 through the defined number of ramp segments are valid) in units of kilogauss/second or minute, or tesla/second or minute (per the selected field units and ramp rate units), and defines the field upper bound for that segment in kilogauss or tesla (see section 3.7.1 for details of the use of ramp segments). This command requires that a coil constant be defined; otherwise, an error is generated.

- **RAMP:RATE:FIELD:** *<segment>*?

Returns the ramp rate setting for the specified segment (values of 1 through the defined number of ramp segments are valid) in units of kilogauss/second or minute, or tesla/second or minute (per the selected field units and ramp rate units) and the current upper bound for that range in kilogauss or tesla (per the selected field units). This command requires that a coil constant be defined; otherwise, an error is generated. The two return values are separated by a comma. For example:

```
RAMP:RATE:FIELD:1?  
0.0100,5.0000
```

- **VOLTage:MAGnet?**

Returns the magnet voltage in volts. Requires voltage taps to be installed across the magnet terminals.

- **VOLTage:SUPPLY?**

Returns the power supply voltage commanded by the Model 430 Programmer in volts.

- **CURRent:MAGnet?**

Returns the current flowing in the magnet in amperes. If the magnet is in persistent mode, the command returns the current that was flowing in the magnet when persistent mode was entered.

- **CURRent:SUPPLY?**

Returns the measured power supply current in amperes.

Remote Interface Reference

Ramp Configuration Commands and Queries

- FIELD:MAGnet?

Returns the calculated field in kilogauss or tesla, per the selected field units. This query requires that a coil constant be defined; otherwise, an error is generated. The field is calculated by multiplying the measured magnet current by the coil constant. If the magnet is in persistent mode, the command returns the field that was present when persistent mode was entered.

- INDuctance?

Returns the measured magnet inductance in henries. Note that the magnet must be ramping when this command is executed. Refer to section 3.10.2.5 on page 53.

- CONFigure:RAMPDown:ENABle {0|1}

Enables the external rampdown function. “1” enables while “0” disables. “0” is the default value.

- RAMPDown:ENABle?

Queries whether the external rampdown function is enabled. Returns “1” for enabled while “0” for disabled. “0” is the default value.

- CONFigure:RAMPDown:RATE:SEGments <# segments>

Sets the number of external rampdown segments.

- RAMPDown:RATE:SEGments?

Returns the number of external rampdown segments.

- CONFigure:RAMPDown:RATE:CURRent <segment>, <rate (A/s, A/min)>, <upper bound (A)>

Sets the external rampdown rate for the specified segment (values of 1 through the defined number of rampdown segments are valid) in units of A/sec or A/min (per the selected rampdown rate units), and defines the current upper bound for that segment in amperes.

- RAMPDown:RATE:CURRent: <segment>?

Returns the external rampdown rate setting for the specified segment (values of 1 through the defined number of rampdown segments are valid) in units of A/sec or A/min (per the selected rampdown rate units) and the current upper bound for that range in amperes. The two return values are separated by a comma. For example:

```
RAMPDown:RATE:CURRENT:1?  
0.1000,50.0000
```

Remote Interface Reference

Ramping State Commands and Queries

- `CONFigure:RAMPDown:RATE:FIELD <segment> , <rate (kG/s, kG/min, T/s, T/min)> , <upper bound (Kg, T)>`

Sets the external rampdown rate for the specified segment (values of 1 through the defined number of rampdown segments are valid) in units of kilogauss/second or minute, or tesla/second or minute (per the selected field units and rampdown rate units), and defines the field upper bound for that segment in kilogauss or tesla. This command requires that a coil constant be defined; otherwise, an error is generated.

- `RAMPDown:RATE:FIELD: <segment>?`

Returns the external rampdown rate setting for the specified segment (values of 1 through the defined number of rampdown segments are valid) in units of kilogauss/second or minute, or tesla/second or minute (per the selected field units and rampdown rate units) and the current upper bound for that range in kilogauss or tesla (per the selected field units). This command requires that a coil constant has been defined; otherwise, an error is generated. The two return values are separated by a comma. For example:

```
RAMPDown:RATE:FIELD:1?  
0.0100,5.0000
```

4.5.6 Ramping State Commands and Queries

The ramping state commands control and query the ramping state of the Model 430 Programmer. For more information regarding each state, see section 3.12.

If the ramping state is commanded remotely, the front panel display and LED indicators will update and accurately reflect the commanded ramping state.

- `RAMP`

Places the Model 430 Programmer in automatic ramping mode. The Model 430 will continue to ramp at the configured ramp rate(s) until the target field/current is achieved.

- `PAUSE`

Pauses the Model 430 Programmer at the present operating field/current.

- `INCR`

Places the Model 430 Programmer in the MANUAL UP ramping mode. Ramping continues at the ramp rate until the Current Limit is achieved.

Remote Interface Reference

Switch Heater Commands and Queries

- **DECR**

Places the Model 430 Programmer in the MANUAL DOWN ramping mode. Ramping continues at the ramp rate until the Current Limit is achieved (or zero current is achieved for unipolar power supplies).

- **ZERO**

Places the Model 430 Programmer in ZEROING CURRENT mode. Ramping automatically initiates and continues at the ramp rate until the power supply output current is less than 0.1% of I_{max} , at which point the AT ZERO status becomes active.

- **STATE?**

Returns an integer value corresponding to the ramping state according to the table below:

Table 4-5. Return Values and Meanings for STATE? Query

Return Value	Meaning
1	RAMPING to target field/current
2	HOLDING at the target field/current
3	PAUSED
4	Ramping in MANUAL UP mode
5	Ramping in MANUAL DOWN mode
6	ZEROING CURRENT (in progress)
7	Quench detected
8	At ZERO current
9	Heating persistent switch
10	Cooling persistent switch

4.5.7 Switch Heater Command and Query

The PSwitch commands control and query the state of the persistent switch heater. For further information regarding the persistent switch heater, see section 3.13 on page 77.

- PSwitch {0|1}

Turns the persistent switch heater OFF and ON. Sending “0” turns the switch heater OFF. Sending a “1” turns the switch heater ON. The default value is “0”.

Remote Interface Reference

Quench State Control and Queries

- PSwitch?

Returns a “0” indicating the switch heater is OFF, or a “1” indicating the persistent switch heater is ON.

- PERSistent?

Returns the state of the "MAGNET IN PERSISTENT MODE" LED on the front panel of the Model 430: ‘0’ if the LED is OFF; “1” if the LED is ON.

4.5.8 Quench State Commands and Queries

The QUench commands control and query the quench state of the Model 430 Programmer. For further information regarding the quench detection functions, see section 3.15.

- QUench {0|1}

Clears or sets the quenched state. Sending a “0” clears any quench condition (equivalent to using the **RESET QUENCH** front panel SHIFT-key). Sending a “1” sets a quench condition. Setting the quench state to “1” is equivalent to a quench detection by the Model 430 Programmer — the power supply output is forced to 0 V, the quench output of the rear panel Quench I/O connector is asserted, and all ramping functions are disabled.

- QUench?

Queries the quench state. If a “0” is returned, no quench condition exists. If a “1” is returned, a quench detect has occurred and is still in effect.

- QUench:COUNT?

Queries the number of recorded quench events.

4.5.9 Rampdown State Queries

- RAMPDownFile?

Formats and sends the contents of the standard rampdown file as a formatted ASCII text stream. This allows the user to view the state of both the magnet and Model 430 Programmer during each recorded rampdown event.

- RAMPDownBackup?

Formats and sends the contents of the rampdown backup file as a formatted ASCII text stream. When the number of recorded rampdown events reaches 100, the standard rampdown file becomes the backup file, and a new (empty) standard rampdown file is created. The standard rampdown file contains data from the most recent rampdown events, and the backup file (if it exists) contains data from the 100 rampdown events preceding the oldest record in the standard rampdown file.

Remote Interface Reference

Quench State Control and Queries

- RAMPDown : COUNT?

Queries the number of recorded rampdown events.

Remote Interface Reference

Trigger Control and Queries

4.5.10 Trigger Functions

The Model 430 Programmer provides trigger functions which provide a means of collecting operational data with a minimum of commands and directing the output to either or both remote interfaces.

4.5.10.1 Description of the Trigger Functions

The Model 430 Programmer defines a *trigger enable register*, very similar to the enable registers of the status system, which controls which data is output and the interface to which the data is presented. The trigger enable register is defined as shown in Table 4-6.

Table 4-6. Model 430 Programmer Trigger Function Bit Definitions

Bit Number	Bit Name	Decimal Value	Definition
0	Magnet Voltage	1	Magnet voltage in volts is included in trigger output.
1	Magnet Current	2	Magnet current in amperes is included in the trigger output.
2	Magnet Field	4	Magnet field in kilogauss or tesla (per the selected field units) is included in the trigger output.
3	Date and Time	8	The trigger date and time is included in the trigger output in the form <i>mm/dd/yyyy hh:mm:ss</i>
4	<i>Not Used</i>	16	<i>Reserved for future use.</i>
5	Formatted Output	32	The trigger output data is formatted.
6	Serial Interface	64	Trigger output data is placed in the serial interface output buffer and transmitted immediately.
7	Ethernet Interface	128	Trigger output data is placed in the Ethernet output buffer.

To enable the trigger functions, the `*ETE <enable_value>` command is written with a decimal value corresponding to the binary-weighted sum of the desired functions. Upon receipt of the `*TRG` command, the Model 430 Programmer places the return data in the appropriate output buffer(s). Data placed in the serial or Ethernet output buffers is transmitted immediately. Note that trigger output data may be placed in both the serial *and* the Ethernet output buffers if desired.

Remote Interface Reference

Trigger Functions

Note

Since trigger data is output immediately to the serial interface, it is possible to use the trigger functions to drive a terminal, modem, or a line printer (if a serial-to-parallel or serial-to-USB converter is available) connected to the serial interface.

If the trigger output data is not formatted, the data will be comma delimited and returned in the order of *time*, *magnet field*, *magnet current*, and *magnet voltage*. Only the data enabled for output will appear in the trigger output string.

4.5.10.2 Trigger Commands and Queries

- `*ETE <enable_value>`

Enables trigger functions according to the definitions in Table 4-6. To enable the trigger functions, you must write a decimal `<enable_value>` which corresponds to the binary-weighted sum of the functions you wish to enable. For example, to enable *formatted* output of the *time*, *magnet field*, and the *magnet voltage* to the serial interface, send the command:

```
*ETE 109;
```

The return data in the serial output buffer would appear as (with the field units selected as tesla):

```
10/23/2007 13:03:14, FIELD= 20.002 T, VOLTAGE= 2.05 V
```

- `*ETE?`

The `*ETE?` query returns a decimal sum which corresponds to the binary-weighted sum of the trigger functions enabled by the last `*ETE` command.

- `*TRG`

Initiates trigger output to the enabled interfaces for trigger functions.

4.6 Error Messages

If an error occurs, the Model 430 Programmer will beep, load the internal error buffer with the error code and description, and set the appropriate bits in the standard event and status byte registers if enabled by the user. Error codes are returned with a negative 3 digit integer, then a comma, and then a description enclosed in double quotes.

Use the `SYSTEM:ERROR?` query to retrieve the errors in first-in-first-out (FIFO) order. Errors are removed from the internal error buffer as they are read. The Model 430 Programmer can store up to 10 errors.

If more than 10 errors have occurred, the last error stored in the internal error buffer is replaced with `-304, "Error buffer overflow"`. No additional errors are stored until you have cleared at least one error from the buffer. If no errors have occurred and the `SYSTEM:ERROR?` query is sent to the Model 430 Programmer, the instrument will return:

`0, "No errors"`

Error strings may contain up to 80 characters. Errors are classified in the following categories: *command errors*, *query errors*, *execution errors*, and *device errors*. Each category corresponds to the identically named bit in the standard event register (see section 4.2.3). If an error occurs in any one of the categories, the corresponding bit in the standard event register is set and remains set until cleared by the user.

4.6.1 Command Errors

- `-101, "Unrecognized command"`

The command string sent was not identified as valid. Check the command string for invalid characters or separators, syntax errors, or for errors in the mnemonics. Spaces are not allowed before or after colon separators, and at least one space must separate a command string from the parameter(s).

- `-102, "Invalid argument"`

The argument provided as a parameter for the command was invalid. *Value* arguments must be of the following form:

- an optional plus or minus sign,
- a sequence of decimal digits, possibly containing a single decimal point, and
- an optional exponent part, consisting of the letter `e` or `E`, an optional sign, and a sequence of decimal digits.

Enable_value arguments must be within the inclusive range of 0 to 255.

Remote Interface Reference

Error Messages

- -103, "Non-boolean argument"

The command required a parameter in the form of 0 or 1. No other form of the parameter is allowed.

- -104, "Missing parameter"

The command required at least one argument which was not found before the termination character(s).

- -105, "Out of range"

At least one of the parameter values received was out of the valid range. Refer to the summary of valid ranges for the Model 430 Programmer settings on page 90. Be sure to note the field units and ramp units settings and check any unit conversions.

- -106, "Undefined coil const"

The user attempted to invoke a command with units of field without first setting a value for the coil constant. The coil constant must be a non-zero, positive value.

- -107, "No switch installed"

The user attempted to activate the persistent switch heater when no switch is installed. Before activating the persistent switch heater, the user must indicate a switch is installed and set the switch current and heating time (see page 54).

- -108, "Not Ramping"

The command that was issued requires the Model 430 Programmer to be ramping for the duration of command processing, and the Model 430 Programmer was either not ramping when the command was issued, or stopped ramping before the command processing was completed.

4.6.2 Query Errors

- -201, "Unrecognized query"

The query string sent (identified as a query by a ?) was not identified as valid. Check the query string for invalid characters or separators, syntax errors, or for errors in the mnemonics. Spaces are not allowed before or after colon separators.

- -202, "Undefined coil const"

The user attempted to invoke a query with units of field without first setting a value for the coil constant. The coil constant must be a non-zero, positive value.

Remote Interface Reference

Error Messages

- -203, "Query interrupted"

A new query was processed before the return string of a previous query had been completely transmitted to the host. The new query clears the remaining data and replaces it with the new return string.

4.6.3 Execution Errors

- -301, "Heating switch"

The user attempted to initiate a ramping function during the persistent switch heating period. Ramping functions are disallowed during the heating period.

- -302, "Quench condition"

The user attempted to change the ramping state while a quench condition was active. A quench condition must be cleared via the **RESET QUENCH SHIFT**-key or by remote command before the ramping state can be modified.

- -303, "Input overflow"

The four input buffers are all occupied with unprocessed commands or queries. The command or query is lost. Review the handshaking section on page 104 for directions for avoiding input overflow errors.

- -304, "Error buffer overflow"

More than 10 errors have occurred. For further errors to be recorded in the internal buffer, at least one error must be cleared.

4.6.4 Device Errors

- -401, "Checksum failed"

The non-volatile memory which stores the calibration data for the Model 430 Programmer is corrupted. Contact an Authorized AMI Technical Representative for further instructions. Do not continue to use the Model 430 Programmer to operate a superconducting magnet.

- -402, "Serial framing error"

The baud rate of the Model 430 Programmer and host device are not identical. The host device must be set to the same baud rate as the Model 430 Programmer (115200).

- -403, "Serial parity error"

The number of data bits and/or the parity of the Model 430 Programmer and the host device are not identical. The host device must be set for the

Remote Interface Reference

Error Messages

same number of data bits, stop bits and parity as the Model 430 Programmer (8 data bits, 1 stop bit and no parity).

- -404, "Serial data overrun"

The received buffer of the Model 430 Programmer was overrun. Verify that the host device has hardware handshaking (RTS/CTS) enabled.

Remote Interface Reference

Error Messages

5 Service

5.1 System Component Maintenance

Caution

These electronic devices are sensitive to electrostatic-discharge (ESD) damage when opened (cover removed). Observe all standard ESD precautions when handling opened power supplies and instruments. Refer to section 5.2.1 on page 135.

5.1.1 Model 430 Programmer Routine Maintenance

The Model 430 Programmer was designed and manufactured to give years of reliable service. The only routine maintenance required is to keep the exterior surfaces of the Model 430 Programmer clean by gently wiping with a damp cloth moistened with a mild detergent.

5.1.2 Model 4Q12125PS Power Supply Routine Maintenance

The Model 4Q12125PS is specifically designed to minimize the need for periodic maintenance, and AMI does not recommend a periodic calibration or service. Keep the exterior surfaces clean by gently wiping with a damp cloth moistened with a mild detergent. The inside of the Model 4Q12125PS unit should be periodically cleaned of dust and grime to ensure continued cooling efficiency. The maintenance interval is dependent on the application and environment; in normal laboratory environments the recommended maintenance interval is six (6) months.

5.2 Troubleshooting Hints

The following paragraphs serve as an aid to assist the user in troubleshooting a potential problem with a superconducting magnet system. If the user is not comfortable in troubleshooting the system, contact an AMI Technical Support Representative for assistance. Refer to “Additional Technical Support” on page 143.

5.2.1 Electrostatic Discharge Precautions

The system contains components which are susceptible to damage by Electrostatic Discharge (ESD). Take the following precautions whenever the cover of electronic equipment is removed.

1. Disassemble only in a static-free work area.

2. Use a conductive workstation or work area to dissipate static charge.
3. Use a high resistance grounding wrist strap to reduce static charge accumulation.
4. Ensure all plastic, paper, vinyl, Styrofoam® and other static generating materials are kept away from the work area.
5. Minimize the handling of the system and all static sensitive components.
6. Keep replacement parts in static-free packaging.
7. Do not slide static-sensitive devices over any surface.
8. Use only antistatic type desoldering tools.
9. Use only grounded-tip soldering irons.
10. Use only static-dissipative hand tools (pliers, cutters, etc.).

5.2.2 The Model 430 does not appear to be energized

1. Ensure that the Model 430 Programmer is energized from a power source of proper voltage.

Warning

If the Model 430 Programmer is found to have been connected to an incorrect power source, return the instrument to AMI for evaluation to determine the extent of the damage. Frequently, damage of this kind is not visible and must be determined using test equipment.

2. Verify continuity of all line fuses (F1, F2, F3, F4, F5, F6 and F7) located on the Model 430 Programmer printed circuit board.

Warning

This procedure is to be performed only when the Model 430 Programmer is completely de-energized by removing the power-cord from the power receptacle. Failure to do so could result in personnel coming in contact with high voltages capable of producing life-threatening electrical shock.

- a. Ensure the Model 430 Programmer and all connected components are de-energized by first shutting down the system and then disconnecting the power cord from the power source.

Service

Troubleshooting Hints

- b. Remove the Model 430 Programmer top cover and check all fuses for continuity.
- c. If a fuse is bad, replace with a fuse of identical rating:

Table 5-1. V-V Mode Input Range Picklist Values

Fuse Identification	Fuse Rating	Fuse Size
F1	T 800 mA	5 x 20 mm
F2	T 250 mA	
F3		
F4	T 100 mA	
F5		
F6		
F7		

Caution

Installing fuses of incorrect values and ratings could result in damage to the Model 430 Programmer in the event of component failure.

- c. Replace the fuse and securely fasten the Model 430 Programmer top cover. Reconnect the power-cord.
4. Verify the input voltage selector switch on the Model 430 Programmer printed circuit board is in the proper position for the available input power. Checking the input voltage selector requires removal of the top cover of the Model 430 Programmer. Observe the same safety procedures as presented in step 2, above.

5.2.3 FAILURE TO LOAD message displayed after power-up

1. Power the Model 430 Programmer off using the front panel power switch.
2. Wait at least 15 seconds.
3. Power the Model 430 Programmer on using the front panel switch.

5.2.4 Power supply unstable - magnet voltage oscillates

Note

If the size of the voltage oscillation is small (approximately 0.1 volt or smaller), see step 1, below. If the voltage oscillation is larger than approximately 0.1 volt, see steps 1 through 4, below.

1. Adjust the persistent switch heater current to a value 10 mA larger than the present value. If the oscillation stops, adjust the heater current to as small a value as possible that maintains magnet voltage stability.
2. Verify the power supply controlled by the Model 430 Programmer is configured for remote programming, voltage-to-voltage mode. Consult the manufacturer's operations manual for the necessary power supply configuration.
3. Verify that the persistent switch heater is operating. Also, verify that the actual persistent switch in the magnet is correctly installed and connected.

Note

If the persistent switch heater is activated without an inductive load present at the supply outputs, oscillating current will result. The Model 430 Programmer is designed to operate large inductive loads with only relatively small resistive characteristics (i.e. superconducting magnets). The Model 430 Programmer is not designed for use as a general purpose power supply controller for resistive loads.

4. If the magnet has no persistent switch installed, or has a small inductance (typically less than 3 H), then adjust the stability setting for the Model 430 Programmer. As this setting is increased, the system should become more stable. For best results, minimize the amount that this value is adjusted from 0.0%. Refer to section 3.10.2.1.

5.2.5 The power supply system will not charge the magnet.

1. Verify system interconnecting wiring. Refer to section 2.5. If the Model 430 Programmer shows "+0.00 A ↑ Status: Ramping" with the supply voltage, V_s , increasing or at the programmed Voltage Limit (as indicated by the reverse video "V" status indicator), there may be a problem with the power supply. Verify the power supply is on and the program out connection from the Model 430 Programmer to the program voltage input to the power supply is intact.

2. Verify the power supply is configured for remote programming, voltage-to-voltage mode.

5.2.6 Cannot charge the magnet at the selected ramp rate.

1. Ensure the Model 430 Programmer is properly configured for the connected power supply. See section 3.10.1.
2. Ensure that the persistent switch heater is on and the switch heated time has expired. Ramping is disabled during the switch heating period.
3. Check the value of the Voltage Limit. Refer to section 3.7.2.
4. Check for excessive wiring resistances in the magnet-power supply loop which may prevent proper charge/discharge voltages at the magnet. Use the local voltmeter on the power supply to see if the proper voltages exist across the various components in the magnet power loop. Loose or oxidized interconnections often exhibit excessive resistances.

5.2.7 Cannot discharge the magnet at the selected ramp rate

1. Ensure that the persistent switch heater is on and the switch heated time has expired. Ramping is disabled during the switch heating period.
2. Check the value of the Voltage Limit. Refer to section 3.7.2.

5.2.8 Cannot charge the magnet to desired field.

3. Ensure that the Model 430 Programmer supply setup submenu is configured to match the connected power supply, e.g. check that the Model 430 Programmer is configured for the proper voltage-to-voltage programming range according to section 3.10.1.1.1.5.

5.2.9 Current in only one direction from 4-quadrant supply

1. Ensure the Model 430 Programmer is configured to allow negative power supply voltage according to section 3.10.1.1.1.1 and negative power supply currents according to section 3.10.1.1.1.3.
2. Verify that the Model 430 Programmer is configured for the proper voltage-to-voltage programming range according to section 3.10.1.1.1.5.

5.2.10 Cannot place the magnet in persistent mode.

Ensure there is adequate LHe level in the cryostat to allow the persistent switch to cool to the superconducting state.

5.2.11 Cannot bring the magnet out of persistent mode.

1. If a PSwitch Error was indicated when the **PERSIST. SWITCH CONTROL** key was used to turn on the persistent switch heater current, then there is a problem with the wiring to the persistent switch heater. Check the continuity between the persistent switch heater power supply output pins at the rear panel **MAGNET STATION CONNECTORS** and the connectors on the magnet support stand top plate. Refer to Table A-1 on page 145.
2. Verify that the output of the persistent switch heater is set to the appropriate value. Refer to section 3.10.2.8 and Figure 3-13 on page 73.
3. Ensure that there is sufficient time for the switch to warm before the power supply current is changed. Increase the persistent switch heating time if needed. Refer to section 3.10.2.9.

5.2.12 The magnet quenches for no apparent reason

1. Ensure the magnet is not being charged at a ramp rate exceeding the capabilities of the magnet. Exceeding the designed rate for ramping the magnet may cause a quench or it may turn on protective diodes on the magnet which may appear very similar to a quench.
2. Ensure there is adequate LHe level in the cryostat. For systems operating at less than 4.2K, ensure the magnet is cooled to the temperature specified by the magnet manufacturer.
3. For conduction-cooled magnets, ensure the magnet temperature is proper and in accordance with the magnet manufacturer's specifications.
4. Disable the Model 430 Programmer quench detection feature (see section 3.15.2 on page 88) if you suspect the Model 430 Programmer is falsely indicating a quench condition.

5.2.13 Cannot lower the magnet field

1. Ensure the magnet is not in the persistent mode. Refer to section 3.13.3 for the procedure to remove a magnet from the persistent mode of operation.
2. If a PSwitch Error was indicated when the **PERSIST. SWITCH CONTROL** key was used to turn on the persistent switch heater current, then there is a problem with the wiring to the persistent switch heater. Check the continuity between the persistent switch heater power supply output pins at the rear panel **MAGNET**

STATION CONNECTORS and the connectors on the magnet support stand top plate. Refer to Table A-1 on page 145.

5.2.14 There is excessive LHe boil-off during operation.

Excessive LHe consumption is usually attributable to one or both of the following: thermal energy being conducted into the cryostat or electrical energy being converted into thermal energy within the cryostat. Analyzing the circumstances under which the high boil-off occurs will help determine what is causing the problem.

1. For magnets equipped with switches for persistent operation, verify that the persistent switch heater power supply is operating at the proper current for the installed switch. Excessive currents cause excessive boiloffs. The typical switch requires approximately 45 mA to function correctly. Refer to the documentation provided with the magnet for proper operating current. See Figure 3-13 on page 73.
2. Verify that the protective diodes on the magnet are not turning on. Damaged diodes may short causing current to flow through them whenever magnet current flows and cause excessive heating. This can be identified by observing a change in the apparent field-to-current ratio since some of the current is bypassing the coil. If the boil off rate returns to normal with the magnet de-energized, this may indicate a defective diode.
3. Ensure that there are no inadvertent thermal paths between the cryogenic environment and the 300K environment. Ensure all transfer lines are removed from the cryostat; check the position of break-away vapor-cooled current leads.
4. Ensure the LHe level sensor is not continuously energized if continuous level indication is not necessary.
5. Ensure the vacuum in vacuum-jacketed dewars is of sufficiently low pressure.

5.2.15 Cannot display the magnetic field strength, only current

Enter a coil constant in accordance with section 3.10.2.2 on page 50.

Note

Setup menu limits are always required in terms of current.

5.2.16 Cannot use remote communications commands.

1. Verify your communications cable integrity and wiring. Refer to Table A-8 on page 154 and Table A-9 on page 154 for wiring of remote communications connectors.
2. Check to make sure you are sending the correct termination to the Model 430 Programmer. If you are using RS-232, make sure the baud rate, number of stop bits, and data bits/parity settings of the host device are matched to those of the Model 430 Programmer (see section 4.3). If you are using Ethernet communications, check all Model 430 Programmer network settings (see sections 3.10.4 and 3.10.5).
3. Check your host communications software and make sure it is recognizing the return termination characters from the Model 430 Programmer. The return termination characters are `<CR><LF>`.
4. If the Model 430 Programmer is responding repeatedly with errors, try a device clear command (DCL) or powering the Model 430 Programmer off and then back on. Be sure you are sending valid commands.

5.2.17 Magnet current drifts unacceptably while PSwitch cooling

1. Set the PSwitch Cooling Gain to 25% and cool the switch. Observe the current on the front of the Model 430 Programmer while the persistent switch is cooling
2. If the switch will not lock (cool to superconducting), resulting in a PSW lock error, reduce the PSwitch Cooling Gain by several percent and attempt cooling the switch again.
3. If the switch cools but the magnet current has excessive drift during cooling, increase the PSWitch Cooling Gain value by several percent.

5.2.18 Model 430 appears to lock up when connecting to network

Note

If the IP Address Assignment value is changed, the Model 430 Programmer power must be cycled off for at least 15 seconds and then back on to complete the change.

On power-up, when connecting via Ethernet (Internet Protocol), the Model 430 will display the firmware version screen until an IP address has been obtained. On busy or slow networks, IP address assignment may take several seconds (even as much as a minute or

Service

Return Authorization

so on very slow networks). The additional time required may give the temporary false appearance of Model 430 "lockup".

5.3 Additional Technical Support

If the cause of the problem cannot be located, contact an AMI Technical Support Representative at (865) 482-1056 for assistance. The AMI technical support group may also be reached by internet e-mail at support@americanmagnetics.com. Additional technical information, latest software releases, etc. are available at the AMI web site at:

<http://www.americanmagnetics.com>

Do not return the Model 430 Programmer or other magnet system components to AMI without prior return authorization.

5.4 Return Authorization

Items to be returned to AMI for repair (warranty or otherwise) require a return authorization number to ensure your order will receive proper attention. Please call an AMI representative at (865) 482-1056 for a return authorization number before shipping any item back to the factory.

Service
Return Authorization

Appendix

A.1 Magnet Station Connectors

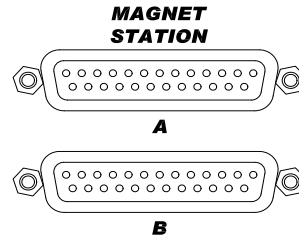

Table A-1. Magnet Station Connectors Pin Definitions

Pin	Function	Pin	Function
1	LHe Sensor I+ (Red)	14	spare
2	LHe Sensor I- (Black)	15	spare
3	LHe Sensor V- (Yellow)	16	spare
4	LHe Sensor V+ (Blue)	17	spare
5	Temperature Sensor I+ (Red)	18	spare
6	Temperature Sensor I- (Black)	19	spare
7	Temperature Sensor V- (Yellow)	20	spare
8	Temperature Sensor V+ (Blue)	21	spare
9	Persistent Switch Heater I+ (Red)	22	spare
10	Persistent Switch Heater I- (Black)	23	spare
11	Magnet Voltage Tap V+ (Yellow)	24	spare
12	Magnet Voltage Tap V- (Blue)	25	spare
13	spare		

The two 25-pin D-sub female Magnet Station Connectors are identically wired and connected pin-for-pin internally. Spare connections may be used for custom coil taps or other signals.

Appendix

Auxiliary LHe Level/Temperature Connectors

Note

For maximum noise immunity, use shielded cabling and connect one end of the shield to the Magnet Station Connector shell.

The connectors provide an interface for connecting a *single* integrated instrumentation cable from the magnet support stand to the Model 430 Programmer. The Model 430 Programmer can then be used to distribute the signals to the appropriate instruments or data acquisition systems. The LHe level and temperature sensor signals are also internally routed to the LHe Level / Temp Connectors.

If the Model 430 Programmer is purchased as part of a magnet system, a Magnet Station Connector instrumentation cable will be provided with the system.

A.2 LHe Level / Temp Connectors

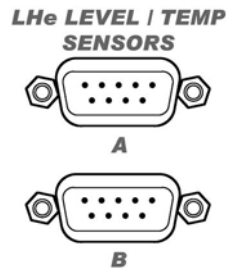

Table A-2. LHe Level / Temp Connectors Pin Definitions

Pin	Function
1	LHe Sensor I+ (Red)
2	Temperature Sensor I+ (Red)
3	Temperature Sensor V- (Yellow)
4	Temperature Sensor I- (Black)
5	Temperature Sensor V+ (Blue)
6	LHe Sensor V- (Yellow)
7	LHe Sensor I- (Black)
8	LHe Sensor V+ (Blue)
9	not used

The two 9-pin D-sub male LHe Level / Temp Connectors are identically wired and connected pin-for-pin internally.

Appendix

Current Transducer Connectors

The connectors route the incoming signals from the Magnet Station Connectors to external level and/or temperature instruments. If an AMI Liquid Helium Level Instrument is purchased with the Model 430 Programmer and magnet system, an LHe level cable will be provided.

Warning



Although the LHe level sensor connector terminals are isolated from earth ground and therefore touching one terminal is not hazardous, the voltage between terminals is at a hazardous potential if an AMI Liquid Helium Level Instrument is connected and energized. The LHe level sensor pins are designed for use with an AMI LHe sensor and the wiring for the sensor is to have no live parts which are accessible. Conductors connected to its terminals must be insulated from user contact by basic insulation rated for 150 VAC (Category I).

Note

For maximum noise immunity, use shielded cabling and connect one end of the shield to the LHe Level / Temp Connector shell.

A.3 Current Transducer Signal Connector

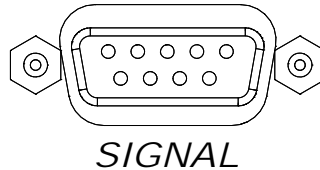

The current transducer signal connector provides pins for connection of the current transducer (CT) signal to the Model 430; power to the CT is also provided via this connector. The connector is a 9-pin D-sub female connector with the shell lugs connected to the Model 430 Programmer chassis ground.

Table A-3. Current Transducer Signal Connector Pin Definitions

Pin	Function
1	V out sense +
2	not used
3	not used
4	power 0 volts out
5	power -15 volts out
6	V out +

Appendix

Current Transducer Connectors

Table A-3. Current Transducer Signal Connector Pin Definitions

Pin	Function
7	V out -
8	not used
9	power +15 volts out

A.4 Current Transducer Power Connector

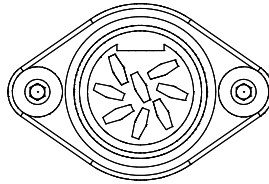

POWER

Caution

Operating the system without power applied to the current transformer (CT) can will result in loss of control, and will probably damage the CT.

The current transducer power connector provides pins for connection of the CT power supply. The connector is an 8-pin female DIN connector with the shell lugs connected to the Model 430 Programmer chassis ground. The pins that receive the power into to the Model 430 are wired internally to the current transducer signal connector for powering the CT.

Table A-4. Current Transducer Power Connector Pin Definitions

Pin	Function
1	not used
2	not used
3	not used
4	not used
5	common
6	-15 volts in
7	+15 volts in
8	common

A.5 Program Out Connector

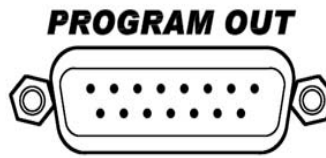

Table A-5. Program Out Connector Pin Definitions

Pin	Function
1	not used
2	not used
3	not used
4	Program Out Common
5	not used
6	not used
7	not used
8	not used
9	not used
10	not used
11	Program Out Voltage
12	not used
13	not used
14	not used
15	not used

The Program Out 15-pin D-sub male connector provides up to a -10 Vdc to $+10$ Vdc output designed to drive the remote *voltage-to-voltage* programming input of a connected power supply. Refer to “Installation” on page 13 for a detailed description of the system interconnections. Pin 11 of the Program Out connector is the program out voltage. Pin 4 of the Program Out connector is the output return. All other pins of the Program Out connector are unused.

Note

For maximum noise immunity, the Model 430 Programmer chassis and the chassis of any connected power supply should be tightly

electrically coupled. This can be accomplished through the rack mounting or by using a grounding strap between the chassis.

A.6 Quench I/O Connector

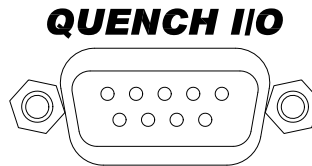

The Quench I/O connector provides pins for external quench detection input, quench detection output, and external rampdown input. The shell lugs of the connector are connected to the Model 430 Programmer chassis ground. The Quench I/O connector is a 9-pin D-sub female connector.

Table A-6. Quench I/O Connector Pin Definitions

Pin	Polarity	Function
1	n/a	Quench Output (Model 430 Programmer NO dry contact)
2		
3	not used	
4	circuit common	Quench Input (customer-supplied external NO dry contact)
5	+	
6	circuit common	Rampdown Input (customer-supplied external NO dry contact)
7	+	
8	not used	
9		

A.6.1 External Quench Detection Input

The external quench detection input allows the user to facilitate his own quench detection circuitry, the output of which is wired to the Model 430 Programmer. The external input overrides the internal quench detection function of the Model 430 Programmer and cannot be disabled.

Caution

The external quench detection input is a dry contact input, not galvanically isolated from the Model 430 Programmer internal circuitry. To avoid noise problems and potential damage to the Model 430 Programmer, it is very important that the dry contacts to

which the input is connected be galvanically isolated from any external circuitry.

It is recommended that the external quench detection input be driven by the contacts of a low level dry contact relay, which will galvanically isolate the input from all other circuitry.

When the external quench detection input pins (pins 4 and 5 of the Quench I/O connector) are shorted together, it is the same as if an Model 430 Programmer internal quench detection occurred. Refer to section 3.15 on page 86 for details.

A.6.2 External Rampdown Input

When enabled¹, the external rampdown input initiates a rampdown of the magnetic field of the magnet when triggered.

Caution

The external rampdown input is a dry contact input, not galvanically isolated from the Model 430 Programmer internal circuitry. To avoid noise problems and potential damage to the Model 430 Programmer, it is very important that the dry contacts to which the input is connected be galvanically isolated from any external circuitry.

It is recommended that the external rampdown input be driven by the contacts of a low level dry contact relay, which will galvanically isolate the input from all other circuitry.

When the external rampdown input pins (pins 6 and 7 of the Quench I/O connector) are shorted together for more than 10 milliseconds, the Model 430 Programmer enters external rampdown mode. If the magnet is in driven mode, the Model 430 Programmer ramps the magnet field/current to zero. If the magnet is in persistent mode, the Model 430 Programmer ramps the power supply to match the persistent magnet current, turns on the persistent switch heater, waits the specified heated time and then ramps the magnet field/current to zero.

This function may be used with an AMI Model 134 or 135 Liquid Helium Level Instrument. The Level instrument has a NO relay associated with the low level condition and this contact closure can be connected to the External Rampdown Input so that when a low helium level occurs in a system, the magnet is safely and automatically ramped down, preventing a magnet quench. AMI offers a cable for this purpose or the user can make

1. Refer to "Enable External Rampdown" on page 58.

a suitable cable to connect pins 5 and 6 on J2 of the 13x instrument to pins 6 and 7 of the 430 Programmer, Quench I/O connector.

Caution

The separate external segmented-rampdown option described below ignores the Voltage Limit during the rampdown process.

Note

If the number of external-rampdown ramp segments is set to zero, the modified rampdown is not used and the standard ramp rate table will be effective during external rampdown. The Model 430 Programmer defaults to an empty rampdown table (number of segments equal zero).

A separate segmented-ramp-rate table is available for external rampdown. This option is accessible only via the external interface commands. See section 4.5.5 on page 120.

A.6.3 External Quench Detection Output

The external quench detection output is a set of dry contacts (pins 1 and 2 of the Quench I/O connector) which *close* when the Model 430 Programmer internal circuitry detects a quench condition. Note that the Model 430 Programmer internal quench detection must be enabled to assure that the Model 430 Programmer will indicate a detected quench (see section 3.10.2.13 on page 57).

The contacts remain shorted (when a quench has been detected) until the RESET QUENCH SHIFT-key is used to clear the quench condition.

A.7 Aux Inputs Connector

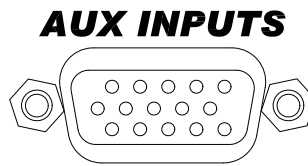

The Aux Inputs connector provides pins for external voltage inputs, reserved for future use. The shell lugs of the connector are connected to the Model 430 Programmer chassis ground. The Aux Inputs connector is a high density 15-pin D-sub female connector.

Table A-7. Aux Inputs Connector Pin Definitions

Pin	Function
1	Aux Input 1 +
2	Aux Input 1 —
3	Aux Input 2 +
4	Aux Input 2 —
5	not used
6	Aux Input 3 +
7	Aux Input 3 —
8	Aux Input 4 +
9	Aux Input 4 —
10	not used
11	Aux Input 5 +
12	Aux Input 5 —
13	Aux Input 6 +
14	Aux Input 6 —
15	not used

Each input pin has a 1 megohm resistor to analog circuit common. The inputs are differential inputs. Aux Input 1 and Aux Input 2 have a ± 1 V nominal input voltage range. Aux Input 3, Aux Input 4, Aux Input 5 and Aux Input 6 have a ± 10 V nominal input voltage range.

A.8 Ethernet Connector

ETHERNET

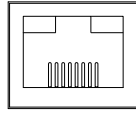
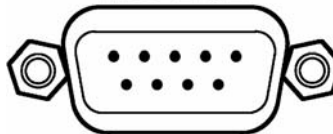

Table A-8. Ethernet RJ-45 Connector Pin Definitions

Pin	Mnemonic	Function
1	TXD+	Transmit differential output +
2	TXD—	Transmit differential output —
3	RXD+	Transmit differential input +
4	not used	
5		
6	RXD—	Transmit differential input —
7	not used	
8		

A.9 RS-232 Connector

RS-232



The RS-232 connector is a standard DTE 9-pin D-sub male connector

Table A-9. RS-232 Connector Pin Definitions

Pin	Mnemonic	Function
1	DCD	Data Carrier Detect
2	RXD	Receive Data
3	TXD	Transmit Data
4	DTR	Data Terminal Ready
5	GND	Signal Ground
6	DSR	Data Set Ready
7	RTS	Request To Send

Appendix

Abbreviations and Acronyms

Table A-9. RS-232 Connector Pin Definitions (Continued)

Pin	Mnemonic	Function
8	CTS	Clear to Send
9	RI	Ring Indicator

Table A-10. PC (DB9)-to-Model 430 RS-232 Cable Connections

PC (DTE) DB9 Pin	Model 430 (DTE) DB9 Pin
1, 6	4
2	3
3	2
4	6, 1
5	5
7	8
8	7

A.10 Abbreviations and Acronyms used in this Manual

Table A-11. Abbreviations and Acronyms

Term	Meaning
AC; ac	Alternating Current; strictly, electrical <i>current</i> that periodically reverses direction. Typically used also to describe an electrical power source in terms of the <i>voltage</i> . For example, 240 Vac.
ASCII	American Standard Code for Information Interchange; numerical representation of characters such as 'a' or '@' or an action (such as line-feed); 'plain' raw text with no formatting such as tabs, bold or underscoring
CR	Text Carriage-Return character
CT	Current Transducer
CTS	DTE clear-to-send signal
DB9	Type of electrical connector containing 9 pins arranged in two parallel rows of 4 pins and 5 pins each)
DB15	Type of electrical connector containing 15 pins arranged in two parallel rows of 7 pins and 8 pins each

Appendix

Abbreviations and Acronyms

Table A-11. Abbreviations and Acronyms (Continued)

Term	Meaning
D-Sub	Term referring to the family of connectors containing an odd number of pins in two parallel rows with a 1-pin difference in pins-per-row (DB9, DB15, and DB25 are most common)
DC; dc	Direct Current; strictly, electrical <i>current</i> that flows in only one direction. Typically used also to describe an electrical power source in terms of the <i>voltage</i> . For example, 12 Vdc.
DCE	Data Communication Equipment: The devices of a communications network, such as modems, that connect the communication circuit between the data source and destination (DTE's).
DHCP	Dynamic Host Configuration Protocol; a computer networking protocol which dynamically distributes the IP address to networked devices
di/dt	Current flow rate of change
DSP	Digital Signal Processing; digital representation and processing of signals typically converted to/from analog signals external to the processor.
DTE	Data Terminal Equipment: the source or destination of data in a communication connection. DTE's are connected to DCE which in turn is connected to the communication channel.
EFT	Electrical Fast Transient
EMC	Electromagnetic Compatibility
E_o	Power supply output voltage
ESD	Electrostatic Discharge
FIFO	First-in / First-out
FTP	File Transfer Protocol
i, I	Electrical current flow
I_o	Power supply output current
IEC	International Electrotechnical Commission
IEEE	Institute of Electrical and Electronics Engineers
I/O	Input/Output; The hardware and associated protocol that implement communication between information processing systems and/or devices. Inputs are the signals or data received by the system or device, and outputs are the signals or data sent from it.
IP	Internet Protocol; when used with "address", refers to a numerical internet address

Appendix

Abbreviations and Acronyms

Table A-11. Abbreviations and Acronyms (Continued)

Term	Meaning
IR	The product $I \times R$: the voltage developed by electrical current flow (I) through a resistance (R)
kG	kilogauss: a magnetic field unit of measurement
L	Electrical circuit inductance measured in henries
LED	Light-Emitting Diode; a semiconductor device that emits light when energized - used for visual status indication
LF	Text Line-Feed character
LHe	Liquid Helium
Max	Maximum
Min	Minimum
ms	Milli-seconds
nom	Nominal
P/S	Persistent switch
pk	Peak
PSw	Persistent switch
PSwitch	Persistent switch
RF	Electromagnetic radiation in the radio frequency spectrum
R_{lead}	Electrical circuit lead or wiring resistance
RTS	DTE ready-to-send signal
RS-232	RS-232 is a long-established standard and protocol for relatively low speed serial data communication between computers and related devices; originally established for teletypewriter communication.
SCPI	Standard Commands for Programmable Instruments
STP	Standard Temperature and Pressure
T	Tesla: a magnetic field unit of measurement; 10 kilogauss
Temp	Temperature
V	Volts
V-V	Voltage-Voltage; the power supply mode in which the output voltage is in direct ratio to the input (reference) voltage; used when a power supply is controlled by Model 430 Programmer.
VA	Volt-amperes ($V \times I$); a unit of electrical reactive power

Appendix

Abbreviations and Acronyms

Table A-11. Abbreviations and Acronyms (Continued)

Term	Meaning
VFD	Vacuum Fluorescent Display; an electronic display device which, unlike liquid crystal displays, can emit very bright, high contrast light in various colors.
V_{lead}	Voltage ($I \times R$) developed across circuit lead or wiring resistance due to current flow
V_m	Magnet voltage
V_s	Power supply voltage

A.11 Model 430 Programmer Specifications

Table A-12. Model 430 Programmer Specifications @ 25°C

Magnet Current Control Parameters	Standard Model 430 Configurations: Programmable Limits								
	±5 A	±10 A	+100 A	+120 A	±125 A	+200 A	±250 A	+300 A	+500 A
Measurement Resolution (µA):	0.625	1.25	6.25	7.5	15.6	12.5	31.2	18.7	31.2
Accuracy (% of I_{max}):	0.04 ^a	0.04 ^a	0.04 ^a	0.04 ^a	0.04 ^a	0.04 ^a	0.04 ^a	0.005	0.005
Minimum Ramp Rate (µA/min):	10	10	100	100	100	100	100	100	100
Maximum Ramp Rate (A/sec):	1	1	10	10	10	20	20	30	30

a. 0.005 for zero flux current sensing (high-stability) system

Additional Model 430 Programmer Specifications

Magnet Current Control

Temperature Coefficient:	0.01% of I_{max} per °C
Stability:	With standard resistive shunt, better than 0.02% of I_{max} after 20 minutes at desired current and better than 0.01% of I_{max} after 60 minutes at desired current With zero flux current sensing option, 0.001% of I_{max} after 10 minutes at desired current
Programming Resolution:	15 digits ^a
Ramp Rate Resolution:	15 digits ^a
Nominal Load Inductance Range:	0.5 to 100 H

Program Out Voltage

Programmable Limits:	-10 to +10 Vdc
Accuracy:	3 mV (0.03% of V_{max})
Temperature Coefficient:	0.2 mV per °C (0.002% of V_{max} per °C)
Resolution:	0.3 mV
Stability:	Better than 10 mV p-p when paused or holding (with 0.5 to 100 H load)

Magnet Voltage Measurement

Maximum Limits:	-20 to +20 Vdc
Accuracy:	20 mV (0.1% of V_{max} per °C)
Temperature Coefficient:	1.5 mV per °C (0.0075% of V_{max} per °C)
Resolution:	10 mV

Persistent Switch Heater Output

Appendix

Model 430 Specifications

Programmable Limits:	0.0 to 125 mA dc
Accuracy:	0.2 mA
Temperature Coefficient:	0.01 mA per °C
Maximum Compliance:	14 V
Resolution:	0.03 mA

Rampdown and Quench Inputs

Open Circuit Voltage:	5 Vdc \pm 5%
Input Resistance:	10 k-ohm \pm 1%

Quench Dry Contact Output

Maximum Switching Voltage:	60 Vdc
Maximum Switching VA:	10 VA
Maximum Switching Current:	500 mA, unless limited by VA rating
Galvanic Isolation:	125 Vdc

Power Requirements

Primary:	100-115 Vac or 200-230 Vac \pm 10% 50 / 60 Hz, 100 VA max., 30 W max.
Real-time Clock Backup Battery:	3 V CR2032 Lithium coin cell

Physical

Dimensions:	89 mm H x 483 mm W x 191 mm D (3.5" H x 19" W x 10.75" D)
Weight:	8.5 lbm (3.9 kg)

Environmental

Ambient Temperature:	Operating: 0°C to 50°C (32°F to 122°F) Non-operating: -20°C to 70°C (-4°F to 158°F)
Relative Humidity:	0 to 95%; non-condensing
Terminal Torque Limit:	48 lbf-in (5.4 N-m)

Standards

EMI/EMC Standards:	EN 61000-4-2	EN 61000-4-3
	EN 61000-4-4	EN 61000-4-5
	EN 61000-4-6	EN 61000-4-8
	EN 61000-4-11	EN 61000-3-2
	EN 61000-3-3	EN 55011
Safety Standard:	EN61010-1	
Installation Category:	Pollution Degree 2, Overvoltage Category II as defined by IEC664	

-
- a. Resolution of the IEEE 754 double-precision floating point type consisting of a 52-bit fraction and 11-bit exponent.

A.12 Power Supply Details

This section provides the technical details of the individual power supply component of the AMI Model 4Q12125PS-430 High-Stability Power Supply System.

Warning

All power supply parameters, both hardware and software, have been set by AMI, and no field adjustments or reconfiguration of the power supply should be attempted in the field.

Service must be referred to authorized personnel. Using the power supply in a manner not specified by AMI may impair the protection provided by the power supply. Observe all safety precautions noted throughout this manual.

Note

These individual power supply unit details are provided for reference only. Some of the basic power supply parameters given in this section will not apply as configured by the factory in the closed loop current feedback configuration under control of the AMI Model 430 Programmer. Refer to section A.11 on page 159 and System Specifications on page 8 for additional specifications relating to the overall system and individual components.

An AMI Model 430 Power Supply Programmer and two Model 4Q06125PS Power Supplies are configured to make up the 4Q12125PS-430 Power Supply System. Each Model 4Q06125PS is a ± 6 volt, ± 125 ampere, 4-quadrant, voltage and current stabilized DC supply. Refer to section A.12.1 for additional electrical characteristics of the Model 4Q06125PS.

Two Model 4Q06125PS Power Supplies are connected in a series configuration to provide the rated voltage, the units in series operating under the control of the Model 430 Power Supply Programmer in a master-slave configuration that, aside from the specified power-up sequence, is transparent to the user.

A.12.1 Model 4Q06125PS Single Unit Electrical Specifications¹

Table A-13 lists Model 4Q06125PS electrical specifications.

Table A-13. Model 4Q06125PS Electrical Specifications

Specification	Rating / Description		Condition
OPERATING CHARACTERISTICS			
Output Range	E_o Max	±6 Vdc	When connecting active loads, the steady-state voltage of the active load must not exceed the maximum voltage rating of the power supply. Otherwise the overvoltage protection will shut down the power supply.
	I_o Max	±125 Adc	
Closed Loop Gain	Voltage Channel	0.6	
	Current Channel	12.5	
INPUT CHARACTERISTICS			
Voltage	Nominal	230 Vac	Single phase
	Range	176 - 264 Vac	
Frequency	Nominal	50 - 60 Hz	>65 Hz, leakage exceeds spec
	Range	47 - 65 Hz	
Current	176 Vac	9.5 A	Maximum
	264 Vac	6.4 A	
Power factor	0.99 minimum		Nominal output power, source
Efficiency	50%		Minimum, source
Switching frequency	50 KHz		PFC Stage
EMC (Electromagnetic Compatibility) Compliance	EN61326-1 (1997)		Class A equipment
EMC immunity to:	ESD	EN61000-4-2	Electrostatic discharge
	Radiated RF	EN61000-4-3	Radio Frequencies
	EFT	EN61000-4-4	Electrical fast transient/burst
	Surges	EN61000-4-5	
	Conducted RF	EN61000-4-6	
EMC emissions	Conducted	EN61000-3-2	Harmonics
		EN61000-3-3	Fluctuation & flicker
	Radiated	EN55011/CISPR11	0.15 to 30 MHz
			30 to 1000 MHz
Leakage current	3.5 mA		230 Vac, 47-63 Hz

1. Details for the stand-alone units are provided for reference only. Many of the basic power supply parameters will not apply in the closed loop current feedback system application with the AMI Model 430 Programmer controlling current in the outer loop.

Appendix

Power Supply Details

Table A-13. Model 4Q06125PS Electrical Specifications (Continued)

Specification		Rating / Description	Condition
Insulation coordination	Input	Installation Category II	
		Overvoltage Category II	
	Output	Installation Category II	
		Overvoltage Category II	
Pollution degree		2	

OUTPUT CHARACTERISTICS¹

NOTE 1 - Output characteristics are for a single standalone unit.

Type of stabilizer		Voltage-current, 4-quadrant	Switch mode
Switching frequency		100 KHz	Output Stage
Source adjustment range	Voltage	-6 V to +6 V	0 to 50°C
	Current	-125 A to +125 A	
Sink adjustment range	Voltage	-6 V to +6 V	0 to 50°C, recuperated energy is returned to line
	Current	-125 A to +125 A	
Voltage stabilization (voltage mode)	Source effect	±3 mV	Min-max input voltage
	Load effect	±6 mV	0-100% load current
	Time effect (drift)	±3 mV	0.5 through 24 hours
	Temperature	±3 mV/°C	0 to 50°C
	Ripple and noise	±120 mV p-p	Includes switching noise
Error sensing		0.1 V per wire	Above rated output
Transient recovery in voltage mode	Maximum excursion	±300 mV	Nominal voltage, 50% load step
	Recovery time	200 μsec	Return within 0.1% of set voltage
Isolation	Voltage	100 V	Output to ground
Series operation		Master/slave	Maximum of 2 identical units.
Output Stage Protection		Output overvoltage/overcurrent	Recover by setting input power circuit breaker to off, then on
Input Stage Protection (PFC)		Internal fault	Recover by setting input power circuit breaker to off, then on
		Input circuit breaker overcurrent	Trips circuit breaker to shut off unit
Small signal Bandwidth	Voltage channel	2 kHz minimum	Into nominal resistive load 10% of rating
	Current channel	800 Hz minimum	Into short circuit, 10% of rating
Rise/Fall time	Voltage channel	250/250 μSec	Into nominal resistive load, measured from 10 to 90%, from 0 to ±100% of rating
	Current channel	0.5/0.5 mSec	Into short circuit, measured from 10 to 90%, from 0 to ±100% of rating

GENERAL (ENVIRONMENTAL) CHARACTERISTICS

Temperature	Operating	0 to +50°C	Full rated load
	Storage	-20 to +85°C	
Cooling		Two internal fans	Exhaust to the rear
Humidity		0 to 95% RH	Non-condensing
Shock		20 g 11 mS ±50% half sine	Non-operating
Vibration	5-10 Hz:	10 mm double amplitude	3 axes, non-operating
	10-55 Hz:	2 g	

Appendix

Power Supply Details

Table A-13. Model 4Q06125PS Electrical Specifications (Continued)

Specification		Rating / Description	Condition
Altitude		sea level to 10,000 feet	Consult factory for derating.
Safety Certification		AC power EN 61010-1	CE Mark
Dimensions	English	5.25" X 19" X 21.5"	H X W X D
	Metric	133.3 mm X 482.6 mm X 546.1 mm	
Weight	English	53 lbs	
	Metric	24.1kg	
Connections and Controls	Source power	3-pin IEC connector	Configured by AMI Factory
	Load connections	Nickel-plated copper bus bars	
	Sensing Output Terminal Block	7-pin terminal block	
	Analog I/O control port	15-pin D female	
Crowbar Characteristics	Maximum current:	150 A	Short-circuits the output when there is an internal fault (front panel FAULT LED is on) or when there is a loss of input power.
	Maximum voltage	48 V	
	Contact resistance	0.3 milli-ohms @100 A (typical)	
	On/off timing	25 mS (typical)	

Appendix

Power Supply Details

A.12.2 Model 4Q06125PS Single Unit Dimensional Specifications

Figure A-1 and Figure A-2 show outline drawings of the Model 4Q06125PS with dimensions.

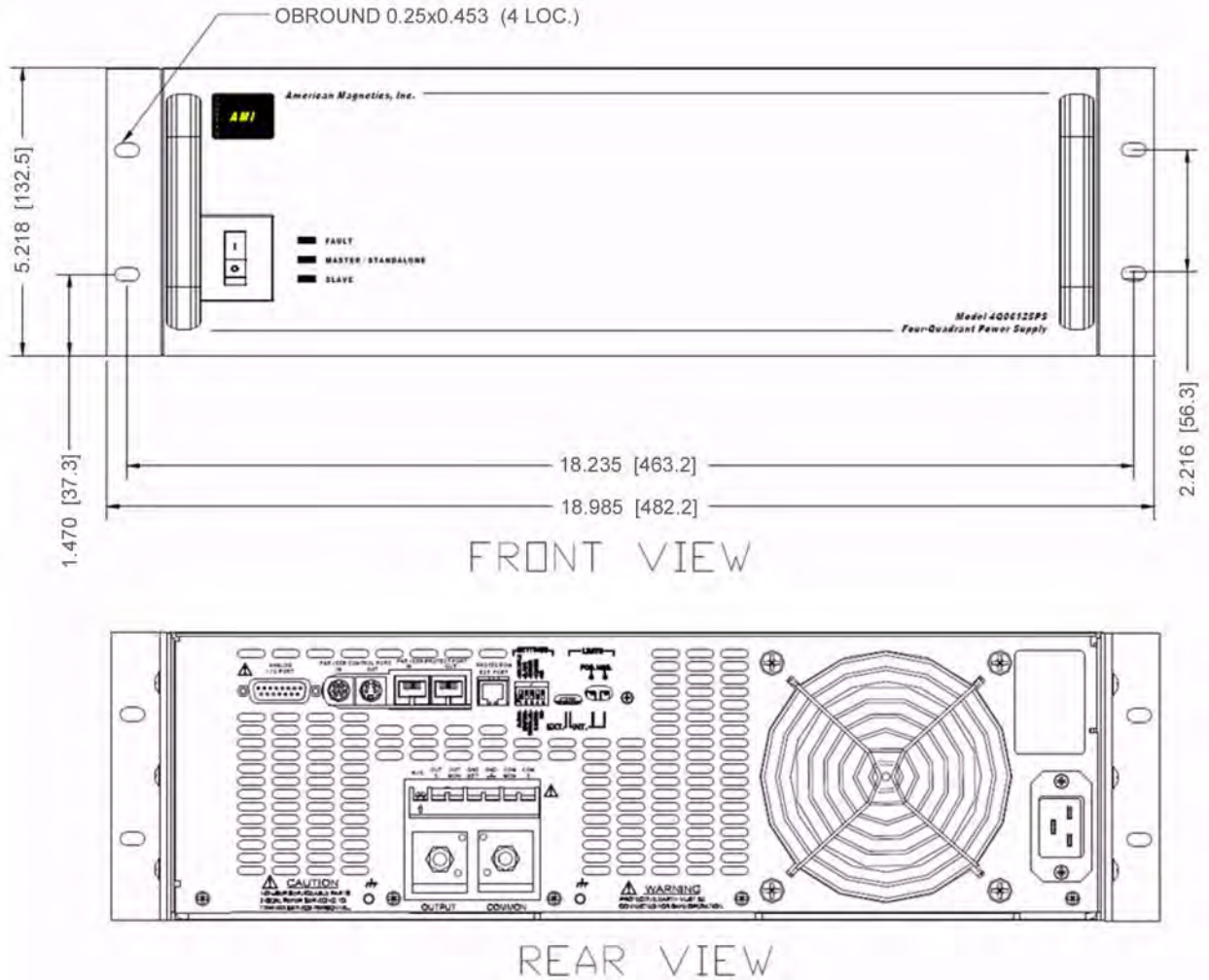

Figure A-1. 4Q06125PS Outline Drawing, Front and Rear Views

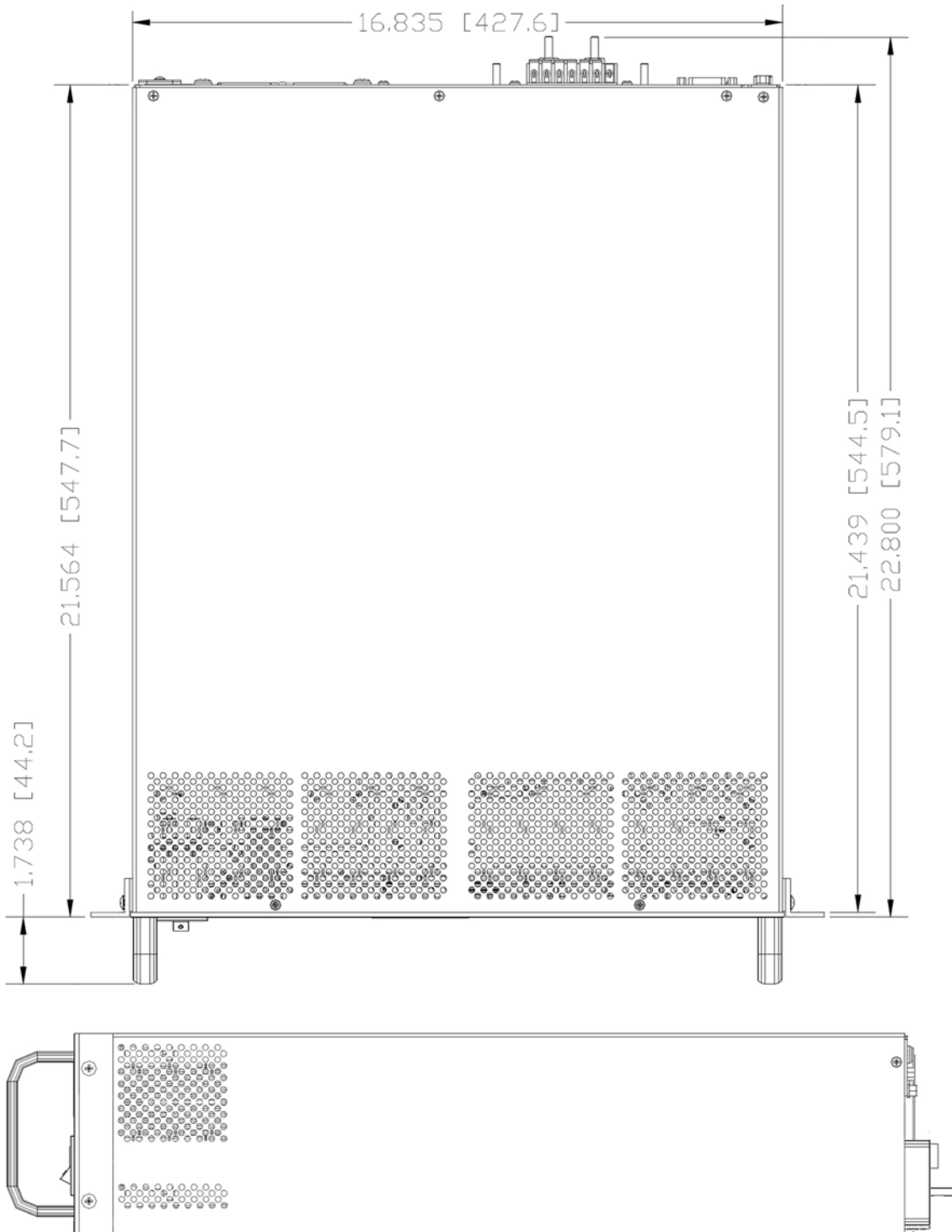

Figure A-2. 4Q06125PS Outline Drawing Top and Side Views

A.12.3 Four-Quadrant Characteristics

The Model 4Q12125PS is a four-quadrant device. Refer to Figure A-3. The

Appendix

Remote Computer Communication (RS-232)

supply operating as a source delivers energy into a load, and as a sink it operates as an electronic load, absorbing and dissipating energy from the load. To minimize energy dissipation, the Model 4Q12125PS employs energy recuperation, where energy from an active load is passed backward through the output circuit and the bidirectional input power factor correcting circuit to the power line. This technology allows high power levels using switch-mode technology while maintaining high efficiency and reduced size and weight.

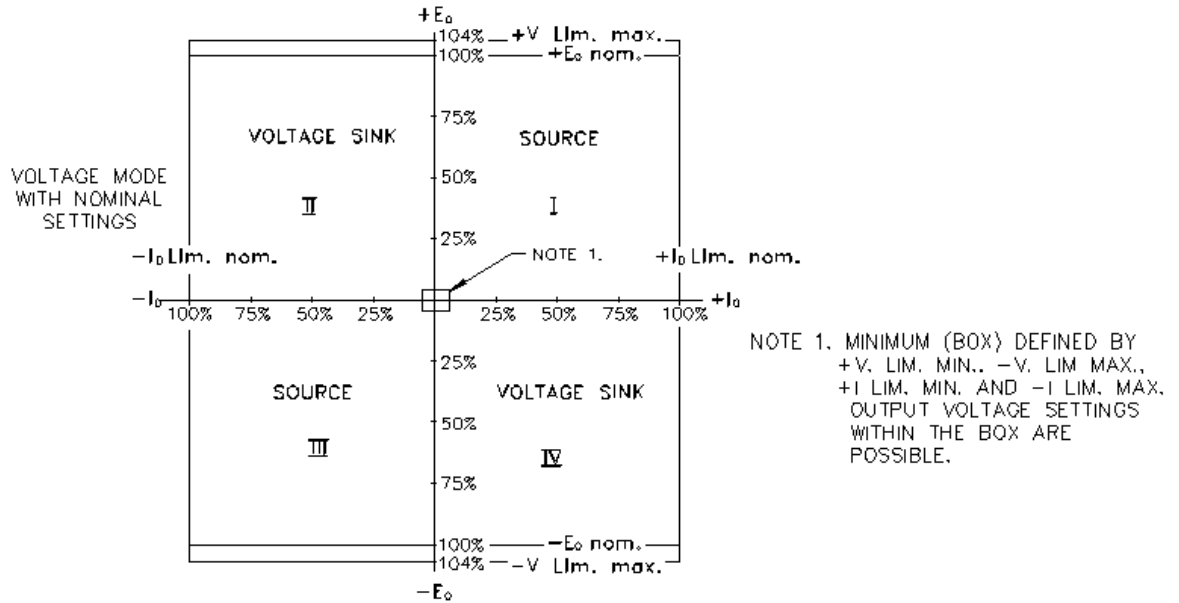

Figure A-3. Four-Quadrant Supply Output Characteristics

A.13 Remote Computer Communication with the Model 430

A.13.1 Communication via RS-232

1. Using serial a null modem cable, connect the DB9 RS-232 connector on the rear of the Model 430 Programmer to a serial connector on the computer.

Appendix

Remote Computer Communication (RS-232)

2. Start a terminal emulator program on the remote computer. As an example, this procedure will use the HyperTerminal program running on a Windows machine.

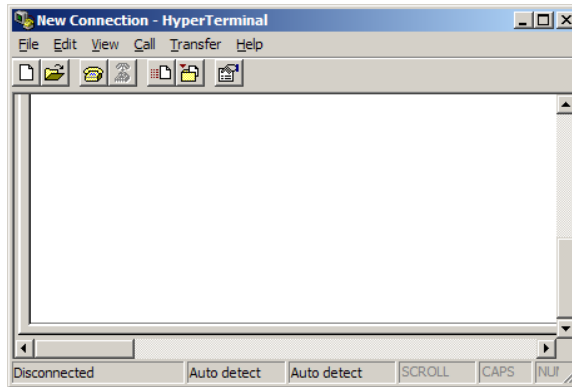

3. Choose *File > New Connection* and in the resulting screen field, enter a name for the connection. Click on OK.

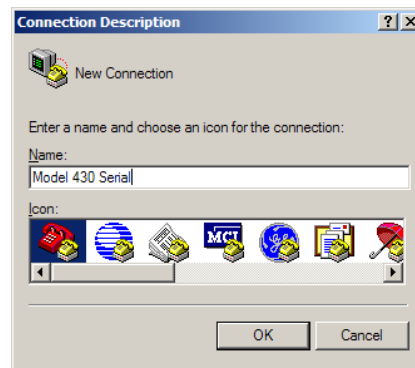

4. From the *Connect using:* pull-down menu, select the appropriate COM port and click OK.

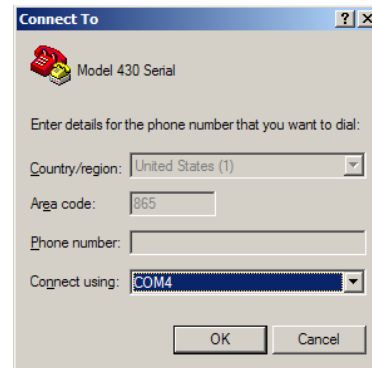

Appendix

Remote Computer Communication (RS-232)

5. Edit the communication parameters per section 4.3 on page 106 and click OK.

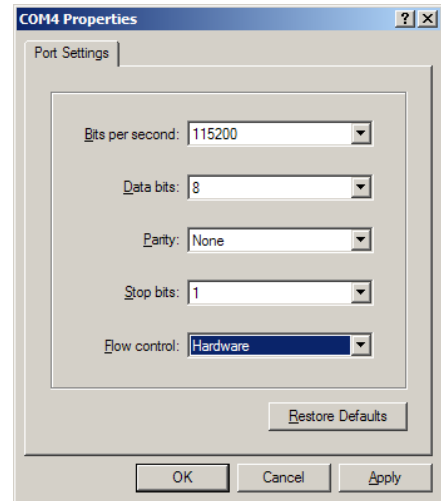

6. Choose *File > Properties* and then click on the *Settings* tab.

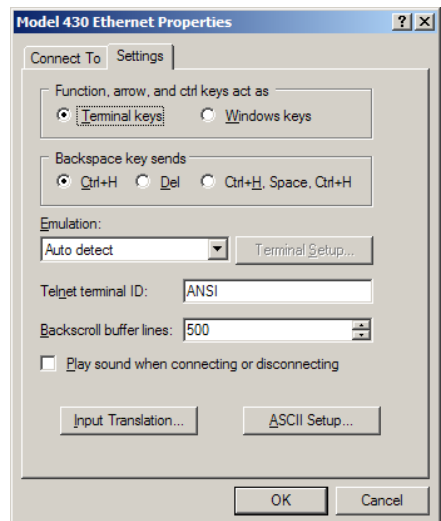

7. Click on the *ASCII Setup...* button and check the *Send line ends with line feeds* box and the *Echo typed characters locally* box in the *ASCII Sending* area. Click on OK and then OK on the next screen.

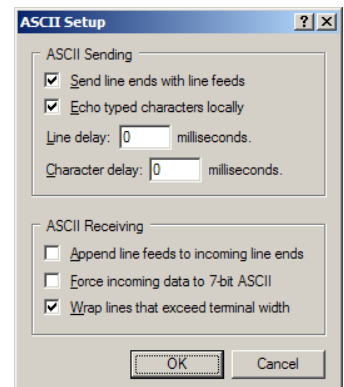

Appendix

Remote Computer Communication (Ethernet)

8. Type *IDN? to test the connection. The Model 430 Programmer should respond with “AMERICAN MAGNETICS, INC., MODEL 430,X.X” where X.X is the firmware version.
9. Issue commands as desired. See “Remote Interface Reference” on page 93.

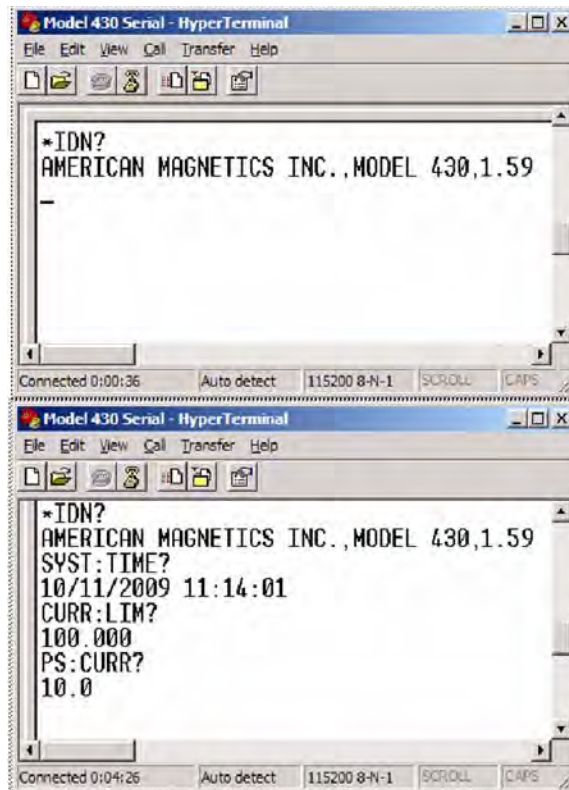

A.13.2 Communication via Ethernet

1. Connect the Model 430 Programmer RJ-45 Ethernet port either directly to a host computer or through a computer network on which the host computer resides:
 - a. For a host computer on a network, connect a standard Ethernet cable between the Model 430 and the network.
 - b. For a direct hardwired connection between the Model 430 and a host computer, use a “null-modem” or “crossover” Ethernet cable connected from the Model 430 directly to the host computer
2. Turn on the Model 430 and press **<ENTER>** at the “Turn on power supply . . .” prompt.
3. Press **MENU** to enter the menu system.
4. Use **<◀>/<▶>** to navigate to the *Net Settings* submenu and press **<ENTER>**.
5. Use **<◀>/<▶>** as necessary to navigate to *Addr Assignment (Present)*.

Appendix

Remote Computer Communication (Ethernet)

Note

The Addr Assignment (Present) must show “DHCP” as originally set by AMI.

Note

In the following step, the IP Address is the four part number separated by periods (.), and will change with each Ethernet connection.

6. Use <◀/><▶> to locate *IP Address (Present)*, similar to that shown in Figure 1.

```
+0.00 A - IP Address (Present)
+0.00 Us 169.254.243.199 (DHCP)
```

7. Make note of the *IP Address (Present)*.

8. Start a terminal emulation program on the remote computer. As an example, this procedure will use the HyperTerminal program running under Windows XP.

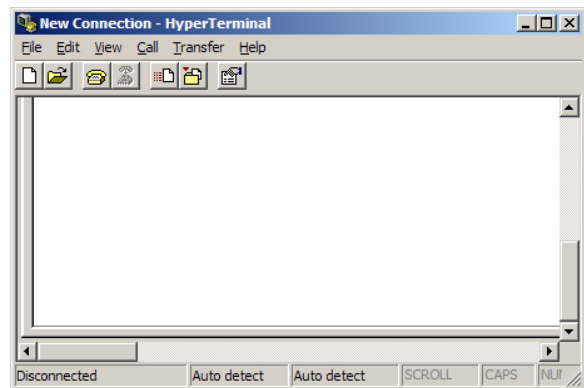

9. Choose *File > New Connection* and in the resulting screen field, enter a name for the connection. Click *OK* - the *Connect to* screen will appear.

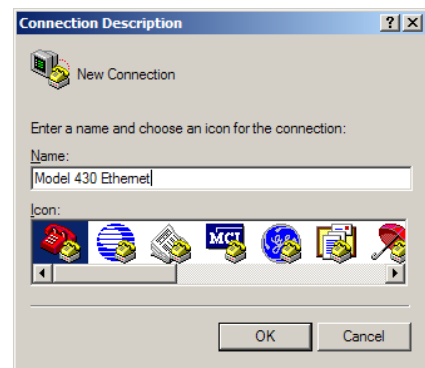

Appendix

Remote Computer Communication (Ethernet)

10. In *Host address*, enter the Model 430 Programmer IP address as determined previously in step 2.
11. Enter 7180 in the *Port Number* field.
12. From the *Connect using* pull-down menu, select *TCP/IP (Winsock)* and click *OK*.

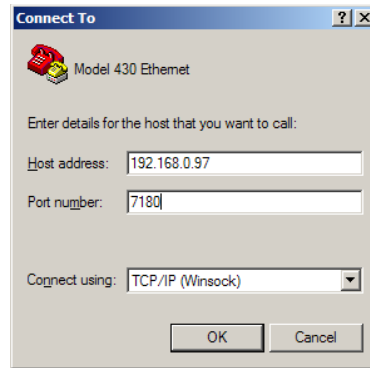

13. The computer will connect with the Model 430 Programmer and display a welcome screen.

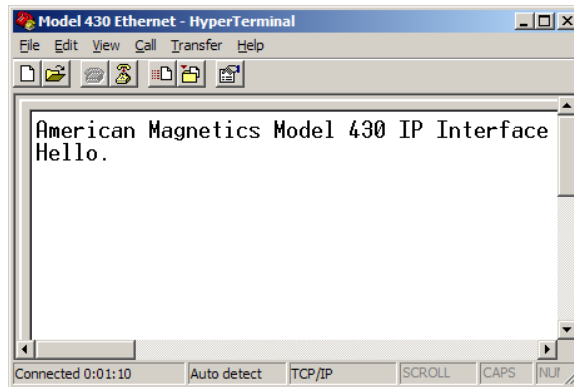

14. Choose *File > Properties* and then click on the *Settings* tab.

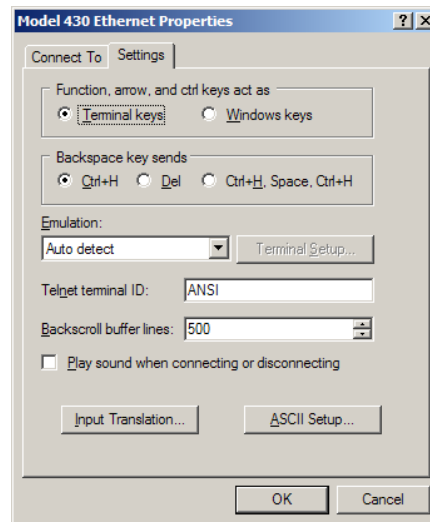

Appendix

Model 430 Firmware Upgrade via FTP

- Click on the *ASCII Setup...* button and check the *Send line ends with line feeds* box and the *Echo typed characters locally* box in the *ASCII Sending* area. Click on *OK* and then *OK*.

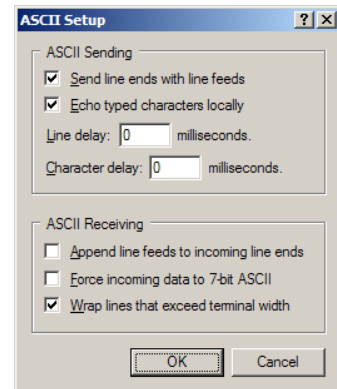

- Issue commands as desired. See “Remote Interface Reference” on page 93.

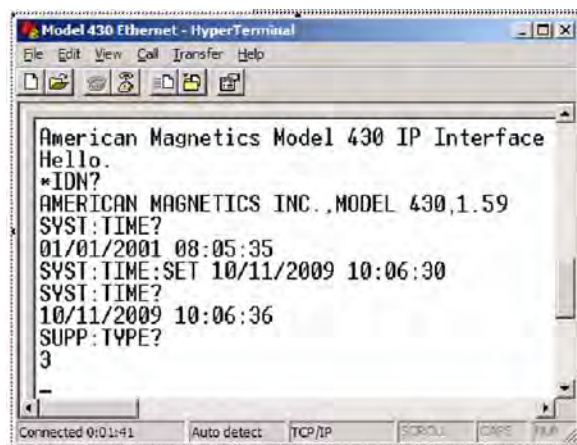

A.14 Upgrading the Model 430 Firmware via FTP

Note

***IMPORTANT** If the Model 430 is being upgraded from Version 1.59 or earlier, proceed to the upgrade procedure in section A.15 on page 180.*

Note

These instructions apply specifically to the Windows XP operating system. For other operating systems, please make adjustments as appropriate.

A.14.1 Hardware and Software Requirements

- Personal Computer (PC) networked by Ethernet to the system on which the target Model 430 resides,
or
PC connected directly to the target Model 430 via a “null-modem” or “crossover” Ethernet cable.

Appendix

Model 430 Firmware Upgrade via FTP

2. The Model430.exe upgrade file extracted from the zip file (typically of the same name) provided by AMI.
3. FileZilla¹ or other appropriate FTP Client installed on the PC. For this procedure an FTP client called FileZilla is used.

A.14.2 Preparation

1. Install FileZilla or another appropriate FTP Client on the PC that will be used for the upgrade.
2. The AMI Model 430 can be upgraded through a file server, or similar network, or via direct Ethernet connection to the PC:
 - a. Via Network:
 - (1.) Make a new “Upgrade” folder located in an appropriate location on the file server.
 - (2.) Extract and save the AMI-supplied upgrade-file, Model430.exe, to the new folder.
 - (3.) Ensure that the PC is connected to the network.
 - (4.) Ensure the Model 430 is connected to the network via standard Ethernet cable.
 - b. Direct PC-to-Model 430:
 - (1.) Make a new “Upgrade” folder located in an appropriate location on the PC.
 - (2.) Extract and save the AMI-supplied upgrade-file, Model430.exe, to the new folder.
 - (3.) Connect the PC to the Model 430 using a “null-modem” Ethernet cable (also referred to as an Ethernet “cross-over” cable).
3. Turn on the Model 430 and press **<ENTER>** at the “Turn on power supply . . .” prompt.
4. Press **MENU** to enter the menu system.
5. Use **<◀/>/▶>** to navigate to *Net Settings* submenu and press **<ENTER>**.
6. Use **<◀/>/▶>** as necessary to navigate to *Addr Assignment (Present)*.

1. Available free at <http://filezilla-project.org/>

Appendix

Model 430 Firmware Upgrade via FTP

Note

The Addr Assignment (Present) must show “DHCP” as originally set by AMI.

Note

In the following step, the IP Address is the four part number separated by periods (.), and will change with each Ethernet connection.

7. Use <◀>/<▶> to locate IP Address (Present), similar to that shown in Figure 1.

```
+0.00 A - IP Address (Present)
+0.00 Us 169.254.243.199 (DHCP)
```

8. Make note of the IP Address (Present).

A.14.3 Procedure

Note

The result of each of the following steps is depicted in the figure appearing above or below the action described. The actual screens will vary depending on the files and file structure on the users PC or file server, and whether FileZilla is used as the FTP Client.

1. Open the FileZilla client application—a screen similar to the following will appear:

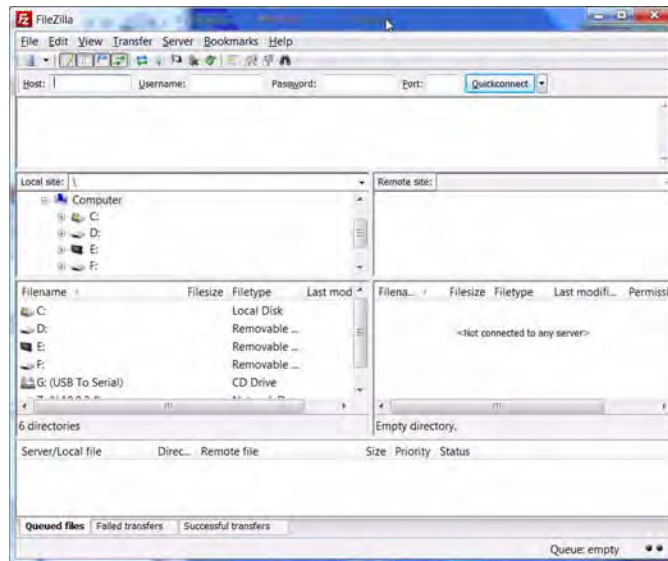

2. Enter the following information in the applicable fields:
 - a. Host: the *IP Address (Present)* as noted previously

Appendix

Model 430 Firmware Upgrade via FTP

- b. User Name: *model430admin*
- c. Password: *supermagnets*
- d. Port: *21*

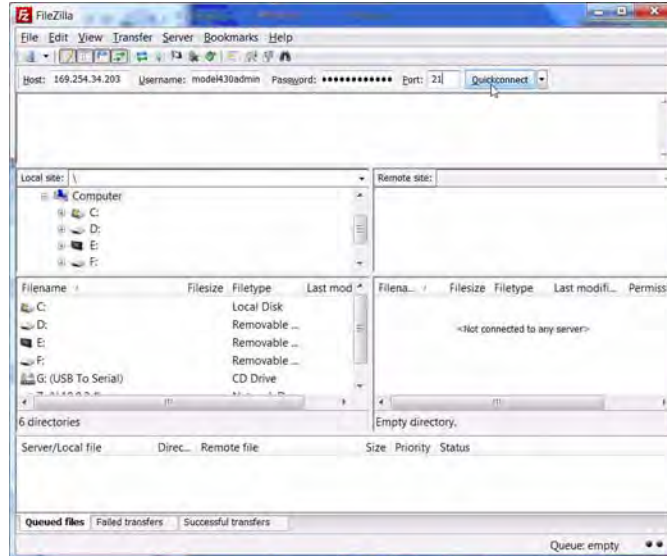

- 3. Click the *Quickconnect* button to connect to the Model 430 – the Remote Site section of the screen will populate.

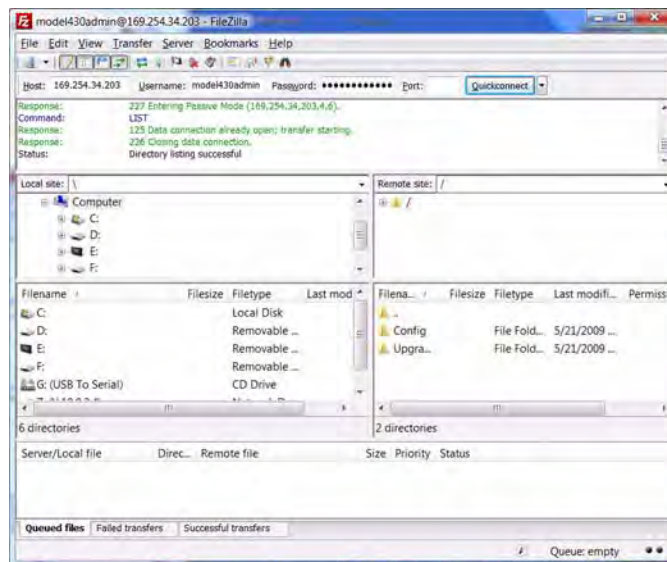

- 4. On the Local Site (left side representing your PC or server file system), navigate to the folder containing the *Model430.exe*

Appendix

Model 430 Firmware Upgrade via FTP

upgrade file (the folder name will be that which was previously given the new “upgrade” folder.).

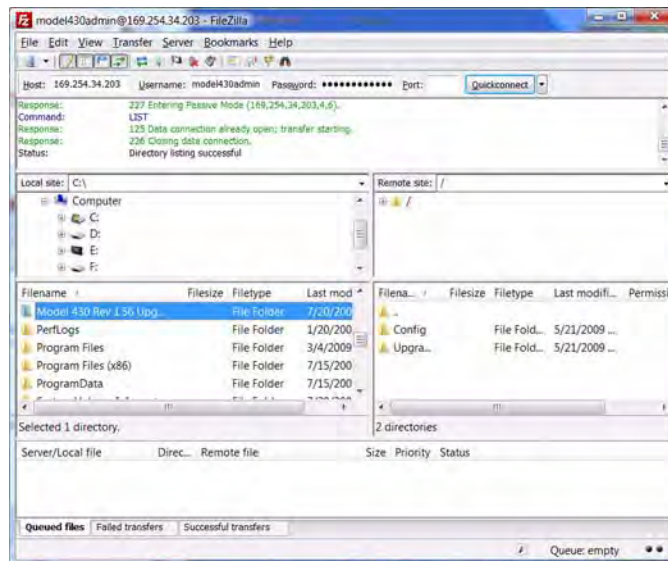

5. Double-click to open the “upgrade” folder on the Local Site (left side) of the screen – the *Model430.exe* file will appear.

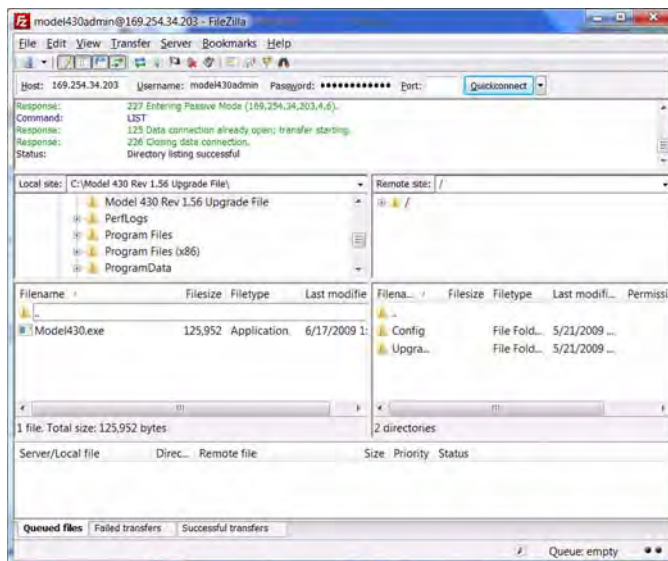

Appendix

Model 430 Firmware Upgrade via FTP

6. On the Remote Site (right side representing the Model 430 files), select the *Upgrade* folder.

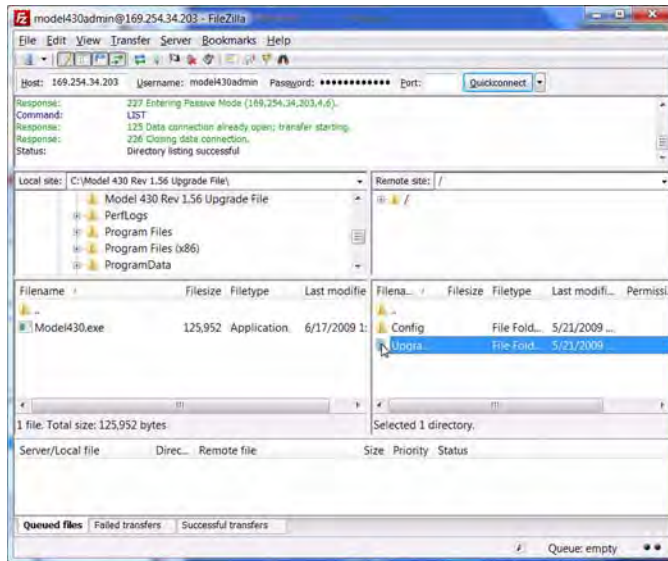

7. Double-click the *Upgrade* folder to open it (the folder will be empty).

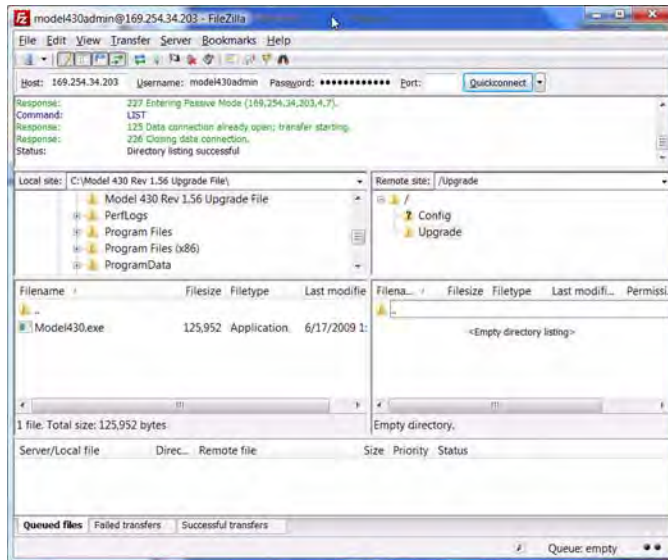

Appendix

Model 430 Firmware Upgrade via FTP

8. Select the *Model430.exe* file from the Local Site (left side) and drag it to the open Upgrade folder on the Remote Site (right side)¹.

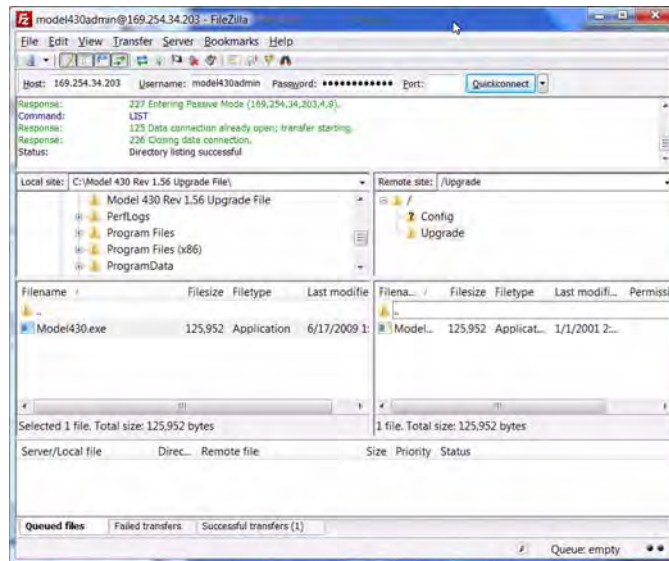

9. Turn off the Model 430.
10. Close the FTP program.

Note

This completes the firmware upgrade. When the Model 430 power is turned on again after powering down, the firmware will automatically upgrade based on the Model430.exe file just placed in its Upgrade folder. View the “Loading. . . .” screen as the Model 430 is “booting” up: the new Firmware Version will momentarily² be displayed.

11. Reboot the Model 430 Programmer by switching the power switch on the front panel off for 10 seconds and then turning the switch back on.
12. Verify that after approximately 20 seconds, the Model 430 display briefly shows the new (upgraded) firmware version³:

```
AMI Model 430 Programmer
Firmware Version: 1.61
```

1. Alternatively, copy *Model430.exe* from the Local Site and paste it to the open folder on the Remote Site.
2. Display time may vary depending on network speed - refer to section 5.2.18 on page 142.
3. Version 1.59 is used only for purposes of this example.

A.15 Upgrading the Model 430 Firmware via Flash Card Reader

Note

These instructions are intended primarily for a Model 430 being upgraded from Version 1.59 or earlier. If the current version is v1.60 or later, upgrade should be performed via FTP according to section A.14 on page 173.

Note

These instructions apply specifically to the Windows XP operating system. For other operating systems, please make adjustments as appropriate.

This is a one-time only procedure - future upgrades will be handled via the Ethernet communications connection on the rear panel of the instrument. An operating system file on the Compact Flash (CF) card mounted inside the Model 430 must be updated to enable the new web server functionality. The file is not accessible via FTP which means the Model 430 cover must be removed, the CF card removed, and the files updated using a CF card reader. Once this upgrade is completed, the CF card should not have to be removed in order to perform future upgrades.

A.15.1 Hardware and Software Requirements

1. The zip file, *Model 430 flash card update.zip*, is required for this upgrade; the zipped files are to be extracted and copied to the CF card.
2. Host computer on a network to which the Model 430 can be connected by standard Ethernet cable
or
Host computer that can be connected directly to the target Model 430 via an Ethernet “null-modem” or “crossover” cable.
3. Standard Ethernet cable or Ethernet “null-modem” cable, as appropriate.

A.15.2 Preparation

Complete the following in preparation for the upgrade.

1. Power down and unplug the Model 430.
2. Remove the cover from the Model 430 as follows:
 - a. Remove the screws securing the cover on the back edges of the instrument (two near each side of the instrument).
 - b. Remove the screws securing the cover just behind the front panel (two on each side of the instrument).
3. Remove the CF card¹ from the Model 430 as follows:

Appendix

Model 430 Firmware Upgrade via Flash Card Reader

- a. Grasp the edges of the card with the thumb and forefinger.
 - b. Gently pull outward to remove the card.
4. Insert the CF card into a CF reader attached to (or internal to) a host computer.
 5. Browse to *My Computer* on the host computer to verify the CF card is visible as a drive.

A.15.3 Procedure

The following steps provide detailed instructions to complete the upgrade.

1. Copy the zip file *Model 430 flash card update.zip* to a location on the host computer – for example, *C:\Model 430\Model 430 v1.60 Upgrade*:

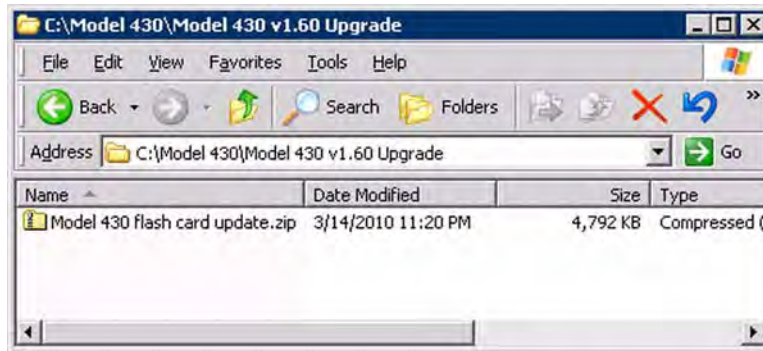

2. Double-click the zip file to open it – the following or similar screen should appear with the files shown:

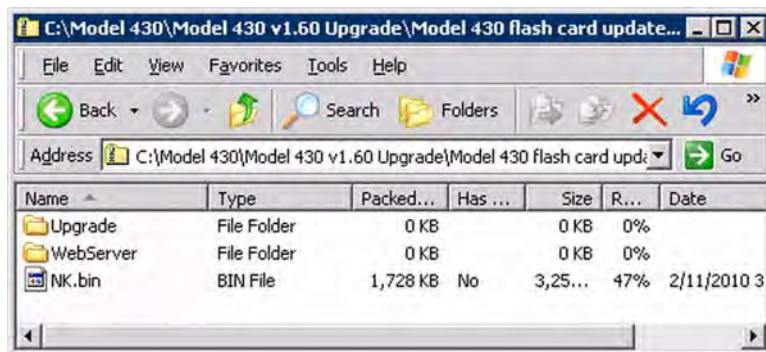

-
1. The Compact Flash card is located at the front right corner of the Model 430 motherboard.

Appendix

Model 430 Firmware Upgrade via Flash Card Reader

3. Choose *File > Extract All...* to start the extraction wizard:



4. Click *Next* until prompted with *Select a Destination*:

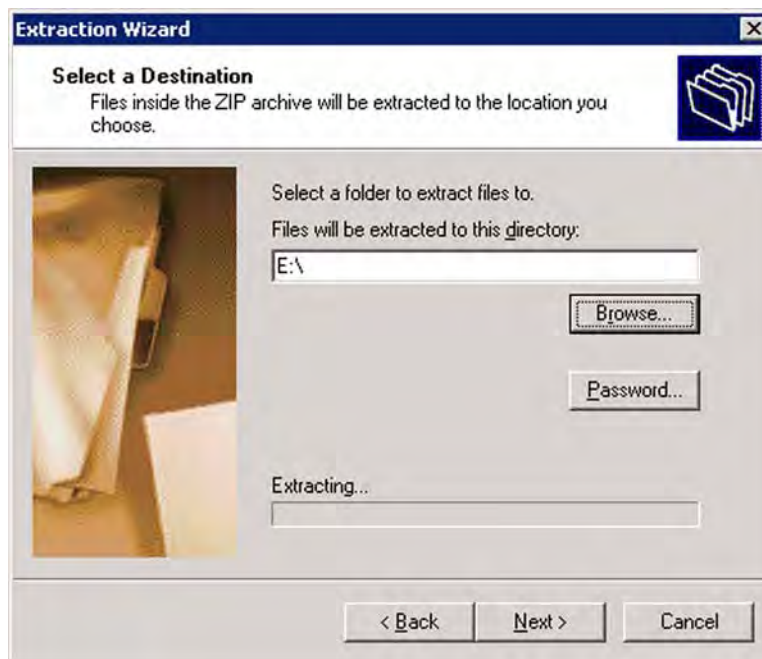

5. Browse to *My Computer* and choose the top level (root) of the drive associated with the CF card (for example **E:** or **G:**) and select *Next*.

Appendix

Model 430 Firmware Upgrade via Flash Card Reader

- When prompted with the *Confirm File Replace* dialog, select **Yes To All**.



- When the extraction process concludes, select **Finish**.
- Close all open windows for the CF drive.
- Use the **Safely Remove Hardware** icon in the tool tray to eject (unmount) the CF card from the host computer.
- Remove the CF card from the card reader.
- Re-install the CF card in the Model 430 - ensure the card is seated properly.
- Re-install the cover on the Model 430 using the previously removed screws.

Note

The Model 430 and the host computer must share the same network address scheme and be attached to the same physical network in the following process.

- Verify that the web interface is functioning correctly as follows:
 - Connect the Model 430 to the host computer using one of the following two methods:
 - Via Ethernet cable to the same physical network as the host computer.
 - Via “crossover” or “null modem” Ethernet cable directly to the host computer’s Ethernet port.
 - Plug in and power up the Model 430.
 - As the Model 430 boots up, watch the front display and verify that it shows *Firmware Version: 1.62*¹ (or other version being upgraded to).
 - Press <**ENTER**> at the *Turn on power supply* prompt.
 - Using the Model 430 menu system, *Menu > Net Settings > IP Address (Present)*, determine the *IP Address* of the Model 430.
 - Open a web browser on the host computer and type the IP address² of the Model 430 into the address bar.

1. Display time may vary depending on network speed - refer to section 5.2.18 on page 142.

Appendix

Model 430:Remote Control Application

g. The following screen should appear:



14. This completes the installation and verification of the Model 430 Firmware Upgrade.

A.16 Model 430 Remote Control Application

Model 430 can be accessed via a network connection^{1,2} with fully functional control³. This is accomplished through the Ethernet connection on the rear panel using TCP/IP protocol via a host computer. The connection and control can be established through a locally connected computer or remotely through a network or even the Internet; the human/machine interface is a web browser depiction of the Model 430.

The browser-displayed Model 430 Programmer can be used to control any Model 430 front panel hardware device except the power switch. Also, any setting changes made at the actual Programmer will be reflected on the displayed version.

The Model 430 Programmer RJ-45 Ethernet port must be connected either directly to a host computer or through a computer network on which the host computer resides:

-
2. In the form <http://xxx.xxx.xxx.xxx>, where the "xxx" values match the *IP Address (Present)* of the Model 430.
 1. The browser must be Java-Applet capable. If the browser displays a message indicating the required Java plug-in needs to be installed, please follow the screen instructions to download and install the plug-in on the browser of host computer.
 2. Third party remote software, such as National Instruments LabView, can also be used.
 3. With the exception of the Power On/Off switch.

Appendix

Model 430:Remote Control Application

1. For a host computer on a network, connect a standard Ethernet cable between the Model 430 and the network.
2. For a direct hardwired connection between the Model 430 and a host computer, use a “null-modem” or “crossover” Ethernet cable connected from the Model 430 to the host computer
3. Once connected, plug in and power up the Model 430.
4. Press <ENTER> after responding to the “Turn on power supply . . .” prompt.

Note

Allow about 90-seconds (from power-up) for the TCP/IP link between the Model 430 and host computer to be established.

In order to access the Model 430 using this application, either the Model 430 *System Name* or *IP Address* must be known. The *System Name* should be available from the Model 430 configuration documentation; the *IP Address* can be determined after Model 430 power-up. The following examples illustrate how the *System Name* or *IP Address* may be determined using the Model 430 menu system:

1. *IP Address: Menu > Net Settings > IP Address (Present).*

```
+0.00 A - IP Address (Present)
+0.00 Us 169.254.91.47 (DHCP)
```

2. *System Name: Menu > Net Settings > System Name (Present).*

```
+0.00 A - System Name (Present)
+0.00 Us A10123_X-AX
```

Open a web browser on the host computer. In the address field, type “http://” followed by either the *IP Address* or *System Name*, and press <ENTER>. For example:

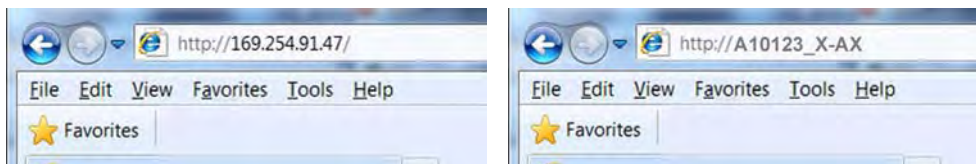

Figure A-4. http:// - IP Address or System Name Entry

Note

If using the System Name, allow about 90-seconds after power-up before typing the http address into the browser and pressing

Appendix

Model 430:Remote Control Application

<**ENTER**>. If entered too soon, re-enter or click the browser “refresh” icon.

The following initial screen should be appear.



Figure A-5. Initial Screen for Browser Access of the Model 430

The *AMI Model 430 Remote Control Application* is the primary feature of this screen. When selected, a view of the Model 430 being controlled with the web browser will appear (under the *Operator Panel* tab).

All functions, except the Power On/Off Switch, are active and operate (using the computer mouse¹) exactly as the hardware Model 430.

The initial screen also includes links to the Model 430 Manual in PDF form along with Frequently Asked Questions relating to the Model 430 application (all stored in the Model 430 firmware). There are links to the AMI website and an e-mail form for contacting AMI Customer Support. The Command Interface is available under the tab of the same name, and operates exactly as described in “Remote Interface Reference” on page 93.

1. To rotate the Fine Adjust Knob (after enabling with the SHIFT key), just click and drag in the desired direction.

Appendix

Model 430IP

A.17 Model 430IP Power Supply Programmer¹

With no front panel controls except the power On/Off switch, the Model 430IP is designed for fully functional control solely through a web browser^{2,3} using TCP/IP via the rear panel Ethernet connection. Operation is very similar to that of the Model 430 Remote Control Application as described in section A.16 on page 184.



Figure A-6. Model 430IP Front Panel

Control can be established through a locally connected computer or remotely through a network or even the Internet; the human/instrument interface is a web browser depiction of the Model 430.



Figure A-7. Browser Depiction of the Model 430

Connect the Model 430IP Programmer RJ-45 Ethernet port either directly to a host computer or through a computer network on which the host computer resides:

1. For a host computer on a network, connect a standard Ethernet cable between the Model 430 and the network.
2. For a direct hardwired connection between the Model 430 and a host computer, use a “null-modem” or “crossover” Ethernet cable connected from the Model 430 to the host computer

Once connected, plug in and power up the Model 430.

1. Requires Model 430 version 1.60 or later firmware.
2. The browser must be Java-Applet capable. If the browser displays a message indicating the required Java plug-in needs to be installed, please follow the screen instructions to download and install the plug-in on the browser of host computer.
3. Third party remote software, such as National Instruments LabView, can also be used.

Appendix

Model 430IP

Note

Allow about 90-seconds (from power-up) for the TCP/IP link between the Model 430 and host computer to be established.

In order to access the Model 430IP using *TCP/IP*, either the Model 430 *System Name* or *IP Address* must be known. The *System Name* should be available from the Model 430IP configuration documentation. If the *IP Address* is assigned statically, it should also be available from the Model 430IP documents.

If the IP Address is assigned dynamically, it will not be known because it changes on each Model 430 power-up; in this case the *IPNAME* must be used (the *IPNAME* is also known as the *System Name*¹). With serial port communication established (refer to “RS-232 Configuration” on page 106), query the unit for *IPNAME* as follows (refer to “SCPI Command Summary” on page 93):

IPNAME?

The port will respond with the *IPNAME (System Name)*.

Open a web browser on the host computer. In the address field, type “http://” followed by the *System Name*, and press <**ENTER**>. For example, with a *System Name* A10123_X-AX:

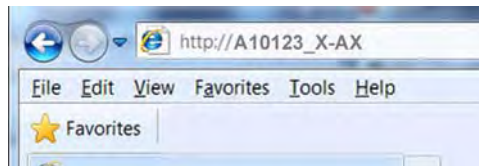

Figure A-8. http:// - System Name Entry

The following initial screen should appear:

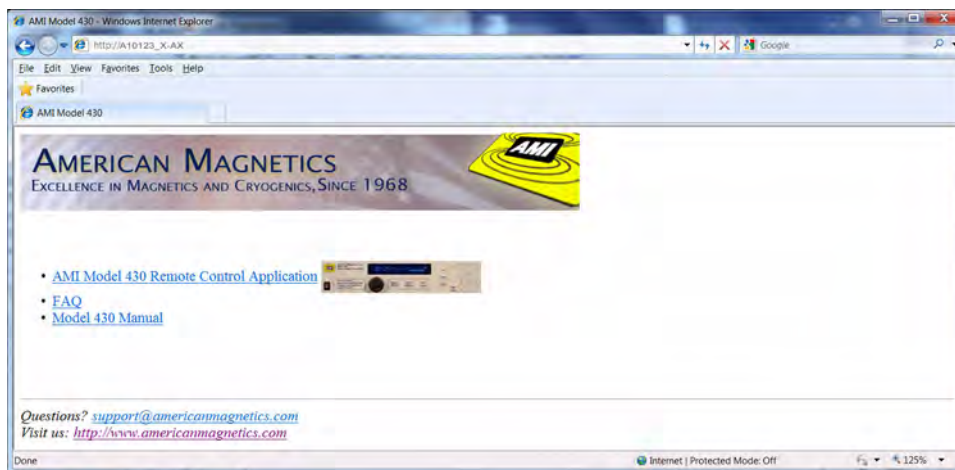

Figure A-9. Initial Screen for Browser Access of the Model 430IP

1. Refer to “Net Settings Submenu” on page 68.

Appendix

Model 430IP

The *AMI Model 430 Remote Control Application* is the primary feature of this page. When selected, a view of the Model 430 being controlled with the web browser will appear (under the *Operator Panel* tab).



Figure A-10. Browser Control of the Model 430IP

All functions, except the power switch, are active and operate (using the computer mouse¹) to control the hardware Model 430.

The initial screen also includes links to the Model 430 Manual (in PDF form) along with Frequently Asked Questions relating to the Model 430. There are links to the AMI website and an e-mail form for contacting AMI Customer Support. Also available is the Command Interface (under the tab of the same name) which operates exactly as described in “Remote Interface Reference” on page 93.

1. To rotate the Fine Adjust Knob (after enabling with the SHIFT key), just click and drag in the desired direction.

A.18 Persistent Switch Operation Flowchart

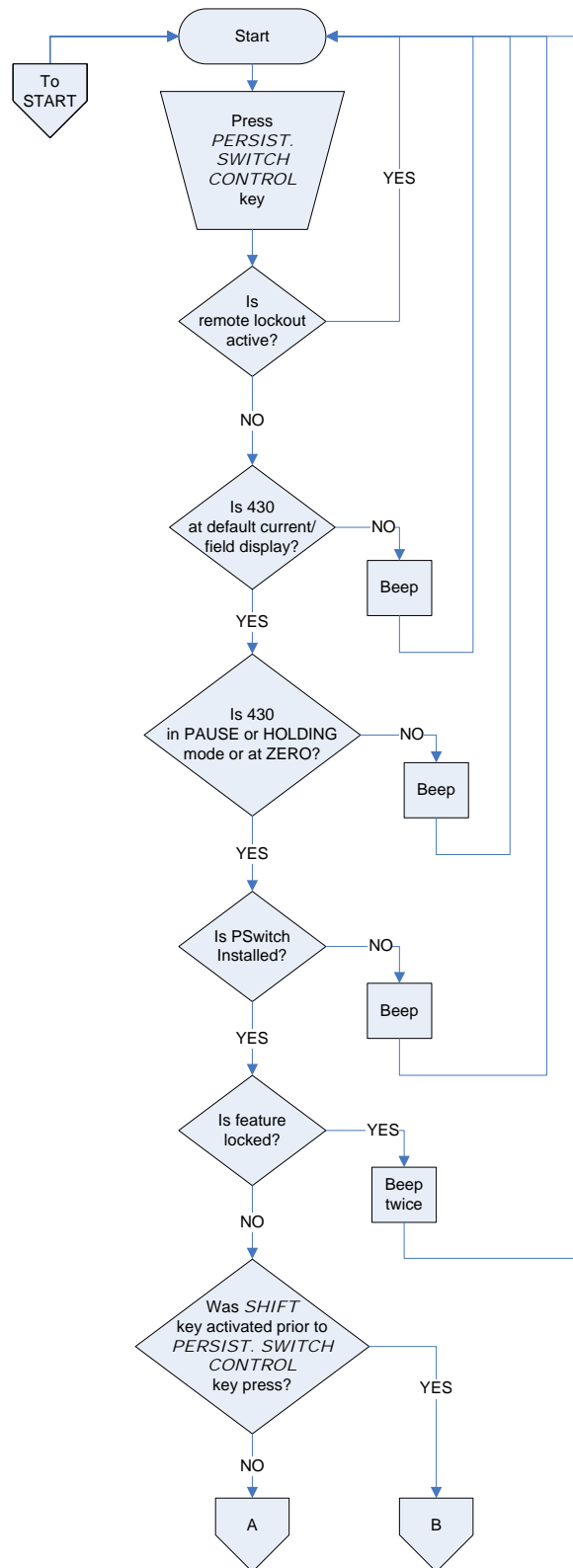

Figure A-11. Persistent Switch Operation Flowchart, Page 1

Appendix

Persistent Switch Operation Flowchart

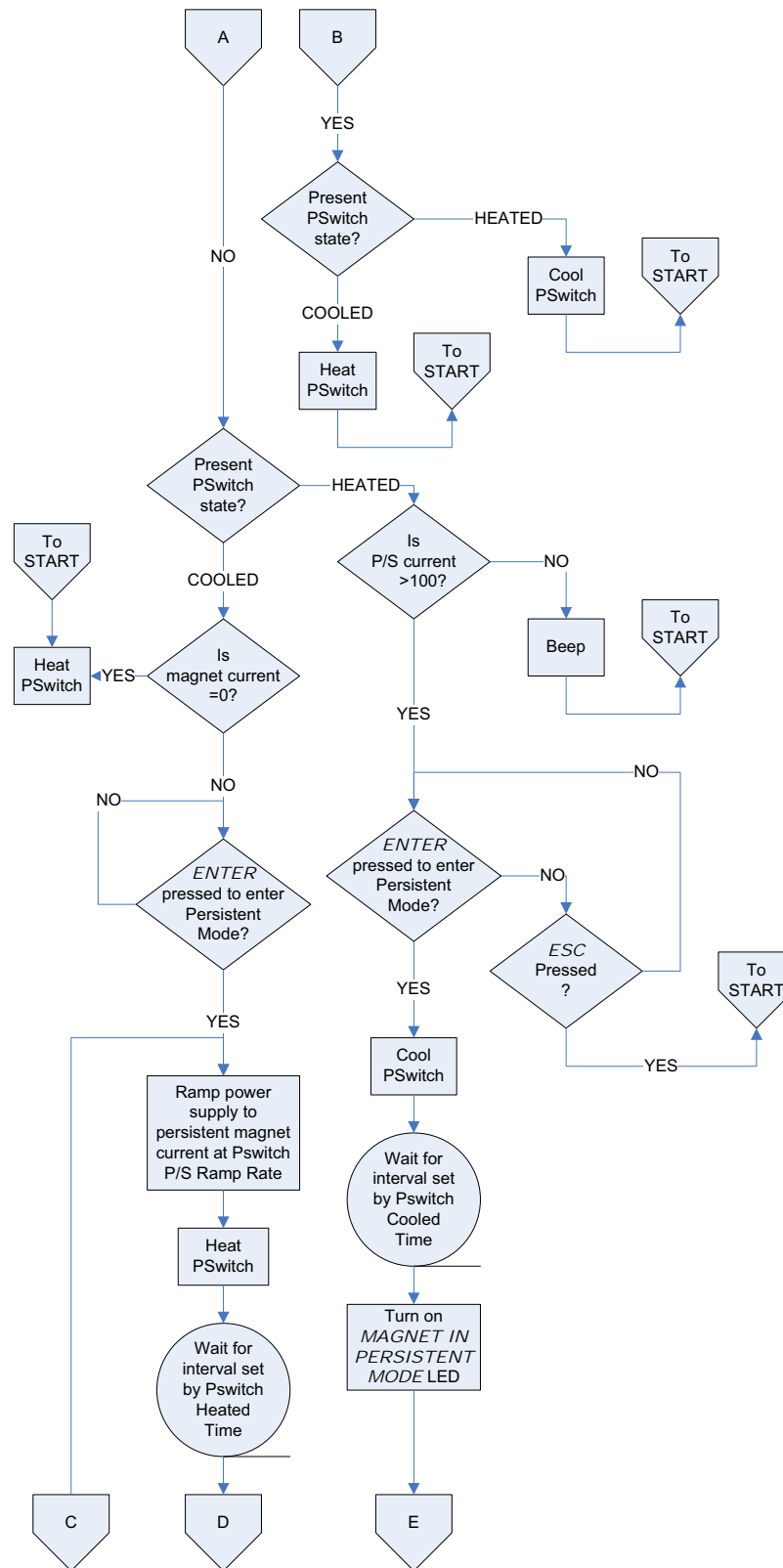

Figure A-12. Persistent Switch Operation Flowchart, Page 2

Appendix

Persistent Switch Operation Flowchart

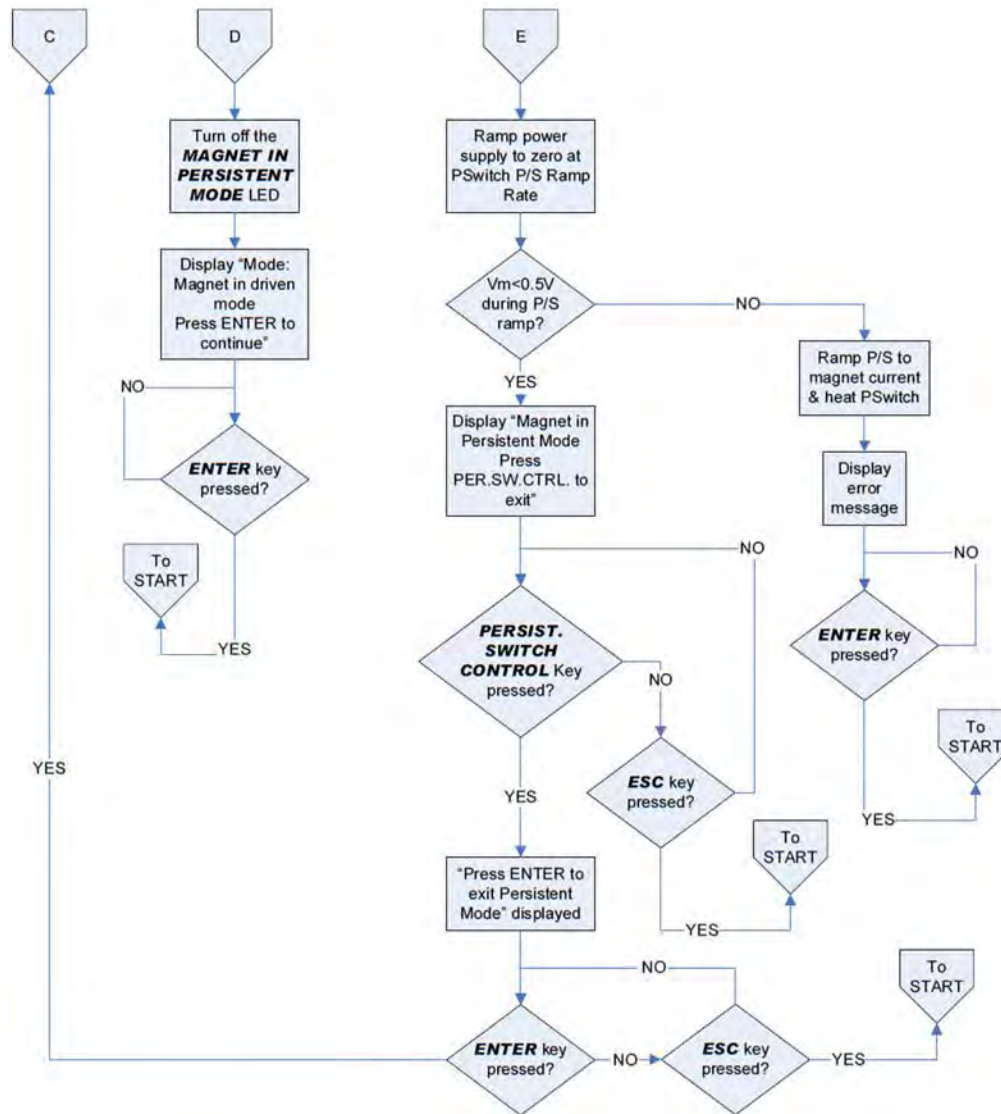

Figure A-13. Persistent Switch Operation Flowchart, Page 3

Index

A

abbreviations and acronyms 155
absolute limits 90
AMI internet e-mail address 143
AMI web address 143

B

beep
 editing PSw P/S ramp rate 34
 editing ramp rate 33
 error messages 130
 incorrect password 61, 68
 locked command 61
 mismatch between pswitch and power supply currents 83
 on initiate ramping 30
 on select supply 45
 on setting current limit below TARGET FIELD SETPOINT 53
 on setting magnet current rating below TARGET FIELD SETPOINT 52
 parameter outside range 26, 90
 pswitch 29
 pswitch did not properly transition to the superconducting state 80
boot 179, 183
brightness 59

C

cancelling entry 26
cleaning - see routine maintenance
closed-loop control 3
coil constant
 acceptable values 51
 calculate 51
 defined 50
 lock 65
command
 error messages 130
 device errors 132
 query errors 131
 in remote control application 186
 overview 100
 command handshaking 104
 condition register 100
 event register 101
 SCPI introduction 100
 standard event register 103
 status byte 101
 status system 100
 status system diagram 101
 reference
 locking 115
 protection commands 115
 quench control 126
 ramping commands 120
 ramping states 124

 setup commands 110
 status commands 109
 switch heater control 125
 system commands 108
 trigger commands 129
 trigger functions 128
summary
 conventions 93
 protection commands 95
 protection configuration queries 96
 quench state 99
 ramp configuration 98
 ramping state 99
 setup configuration commands 94
 setup configuration queries 95
 switch heater 99
 system-related commands 93
 trigger control 99

compatible power supplies 50

configuration

 system

 four-quadrant high-current supply 13
 general 13
 master supply 7
 non-standard 16
 power lead size 13
 series supplies 3
 slave supply 7

connectors

 analog I/O 15
 aux input 153
 current transducer power 15, 148
 current transducer signal 15, 147
 Ethernet communication 16, 154
 LHe level/temp 13, 16, 146
 magnet station 13, 15, 145
 program out 15, 149
 quench I/O 16, 150
 RJ-45 - see Ethernet
 RS-232 serial communication 16, 154
 system interconnect 13

current limit 31, 33, 35, 37, 38, 43, 52, 61, 75, 77, 113, 124, 125

current limit example 52
current limit symmetry 53

current transducer

 current direction 15
 power 22
 power connector 148
 signal connector 147

D

data logging 128
de-energizing the system 22
default display modes 23

Index

default password 61
default settings 90
DHCP 70, 72, 171, 175
diode

light emitting - see LED

display

asterisk 25, 28
brightness 59
current 19
field / current 23
field units 23
magnet quench indicator 24
mode status indicators 24
up/down arrow 27
voltage 24, 39

display brightness 59

E

encoder - see fine adjust knob

energizing the system 21

energy absorber

lock 67
present 58

energy recuperation 167

entering values 25

error messages 130

ESD precautions 135

Ethernet

cable 170, 185, 187
configuration
connector 107, 154, 170
termination characters 107
null-modem/crossover cable 170,
173, 185, 187
port 170, 184, 187
slow connection 142

example

current limit setup 53
ethernet communication setup 170
magnet specification sheet 73
Model 430 IP operation 187
Model 430 remote control application
184
power supply outputs 46
ramp rate menus 33
ramping functions 85
RS-232 communication setup 167
setup 72
system setup 72

external quench detect 57, 58

external rampdown 58, 67, 88, 89,
90, 120, 123, 124

external rampdown input 151

F

FAILURE TO LOAD message 21, 137

field display 23

field units 60

fine adjust knob

coil constant 50

current limit 53

custom ps

max output current 48
max output voltage 47
min output current 47
min output voltage 47

displayed up/down arrow 27

enter key vs. esc. key 27

general description 26

immediate affect on the system 27

lock/unlock 65

magnet current rating 52

pswitch cooled time 56

pswitch cooling gain 57

pswitch current 55

pswitch heated time 56

pswitch power supply ramp rate 57

quench rate 60

ramp rate 33

shift key 39

slow/very fine resolution 27

stability setting 49

target current in HOLDING mode 77

to adjust numeric values 26

velocity sensitive 27

voltage limit 36

firmware upgrade

via flash card reader 180

via FTP 173

firmware version screen 142

four-quadrant operation 9, 46, 166

ftp client 175

fuses 137

H

HyperTerminal 168

I

inductance, calculate 53

installation

earth ground 11

magnet system characteristics 12

mounting 11

power 12

unpacking 11

IP Address 69, 70, 71, 72, 106,
107, 142, 156, 171, 172,
175, 183, 184, 185

K

keys

arrows 28

enter 25, 42

esc 26, 42

ESCape 28

fine adjust 27

manual control 75

menu 28

Index

- persistent switch control 29
 - ramp / pause 31
 - ramp rate 33
 - ramp to zero 31
 - ramp/pause 75
 - shift 27
 - shift persistent switch control 29
 - target field setpoint 31
 - voltage limit 36
- L**
- LED**
- current leads energized 41
 - definition 157
 - field at target 19, 40, 89
 - magnet in persistent mode 29, 40, 77, 79, 84, 89, 126
 - magnet quench 41, 86
 - power-on 40
 - shift 32
- limit example 53
- load submenu
- calculate inductance 53
 - coil constant 50
 - current limit 52, 53
 - enable external rampdown 58
 - enable quench detect 57, 58
 - example limits 53
 - pswitch cooling gain 57
 - pswitch cooling time 56
 - pswitch current 55
 - pswitch current detect 54
 - pswitch heated time 55
 - pswitch installed 54
 - pswitch ramp rate 56
 - stability setting 48
- locked 60, 67
- loop gain 49
- M**
- magnet current
- drifts while PSwitch cooling 142
 - oscillating 138
 - rating 31, 33, 35, 37, 38, 51, 52, 66
 - viewing established persistent current 31, 82
- magnet current rating 19
- magnet specs 73
- menu
- cursor 27
 - navigation 27, 42
 - structure diagram 43
- menus
- load submenu 48
 - misc submenu 59
 - net settings submenu 68
 - net setup submenu 70
 - supply submenu 43
- misc submenu
- coil constant lock 65
 - current limit lock 65
 - display brightness 59
 - display brightness lock 67
 - external rampdown lock 67
 - field / current lock 64
 - field units 60
 - field units lock 64
 - fine adjust lock 65
 - increment / decrement field lock 63
 - mag current rating lock 66
 - net setup lock 67
 - persistent switch settings lock 66
 - power supply lock 63
 - pswitch control lock 62
 - quench detect lock 66
 - quench rate 60
 - quench rate lock 66
 - ramp / pause lock 62
 - ramp rate time units 59
 - ramp segments 59
 - ramp settings lock 62
 - reset quench lock 63
 - settings password lock 67
 - settings protection 60
 - stability settings lock 64
 - target field setpoint lock 62
 - voltage limit lock 63
 - voltmeter lock 65
 - Vs / Vm lock 64
- Model 430
- appears to lock up 142
 - remote control application 184
- Model 430IP 187
- N**
- name, system 185
- net settings submenu
- address assignment 69
 - gateway address 70
 - IP address 69
 - subnet mask 69
 - system name 69
- net setup submenu
- gateway IP address 71
 - IP address assignment 70
 - subnet mask 71
 - system IP address 71
- null-modem/crossover cable
- Ethernet 170, 173, 185, 187
 - RS-232 106, 167
- O**
- operating modes

Index

- four-quadrant 9
- operating voltage, changing 12
- operation 21
- operational limits 90

P

- password 61, 67
- persistent mode
 - entering 78
 - exiting 81
 - viewing established magnet current 31, 82
- persistent switch
 - abbreviations 157
 - beep 29
 - control 77
 - cooled time 27, 29, 30, 54, 56, 79, 86, 91
 - cooling 24, 30, 56, 57, 76, 79, 84, 142
 - cooling gain 27, 30, 54, 57, 91, 142
 - current 55
 - current detect 54
 - defaults
 - cooling gain 30
 - cooling period 30
 - heating period 30
 - heated time 27, 30, 54, 55, 78, 80, 83, 91
 - heating 12, 24, 30, 40, 56, 76, 78, 85, 89, 90
 - heating current 27, 30, 54, 55
 - installed? 54, 95, 113
 - not installed on magnet 16, 49
 - pswitch
 - p/s ramp rate 19
 - ramp rate 27, 29, 30, 34, 54, 56, 79, 82, 114
 - settings lock 66, 119
- power supply
 - 4-quadrant high-stability 13
 - compatibility 45
 - displayed current 19
 - displayed voltage 24
 - general description 3
 - operating characteristics 9
 - precise control of current 3
 - ps unit details 161
 - ps unit front panel layout 7
 - routine maintenance 135
 - system integral components 1
 - system interconnects 13
 - system rack layout 4
 - system terminology 155
 - system troubleshooting 135
 - voltage-voltage mode 3

- power up/down sequence 21
- powering system off 22
- powering system on 21
- power-up test 17
- programmed current 31
- protection password 60, 67
- pswitch - see persistent switch

Q

- quench detection 60, 86
 - disabling 57, 88
 - enabling 57
 - external in/out 87, 150
 - indicator 24
 - switch failure 88
- quench rate 60
- quench, magnet xvi

R

- ramp modes 76
- ramp rate time units 59
- ramp segments 59
- rampdown, external - see external rampdown
- ramping
 - automatic ramping 76
 - basic relationships 74
 - direct current manipulation 77
 - example 85
 - manual increment or decrement 76
 - mode symbols 24
 - ramp to zero 77
 - segmented 33, 34, 36, 59, 62, 75, 77, 98, 116, 120, 121, 122, 123, 124, 152
 - states 75, 125
- remote control application
 - command interface 186
 - controls Model 430 184
 - frequently asked questions 186
 - IP address 185
 - links 186
 - mirrored control 184
 - system name 185
 - view of Model 430 186
 - web browser depiction 184
- remote interface reference - see command
- return authorization 143
- RJ-45 connector - see Ethernet
- routine maintenance 135
- RS-232 configuration
 - connector 106, 154, 155, 167
 - null-modem/crossover cable 106, 167
 - parameters 106
 - termination characters 106

S

Index

- safety
 - cryogenics xiv
 - equipment xvi
 - legend xvii
 - quenches xvi
 - segmented ramping 59
 - see ramping, segmented
 - Series Configuration 161
 - settings 60
 - settings password 67
 - settings protection 60
 - setup
 - example 72
 - load submenu 48
 - misc submenu 59
 - supply submenu 43
 - setup lock 67
 - Shift Key Commands
 - Decrement Field 38
 - Field Current 38
 - Field Units 38
 - Fine Adjust 39
 - Increment Field 37
 - Persist. Switch Control 29
 - Persistent Switch Heater Current 39
 - Ramp Rate 33
 - Reset Quench 37
 - Stability 39
 - Volt Meter 39
 - Voltage Limit 36
 - short-circuit operation 17
 - shunt accuracy 19
 - shunt current measurement 159
 - Single-key Commands
 - Persistent Switch Control 29
 - Ramp / Pause 31
 - Ramp To Zero 31
 - Target Field Setpoint 31
 - slow networks 142
 - specifications
 - Model 430 159
 - stability setting 16—??, 17, 39, 48—
50, 138
 - stabilizing resistor 16
 - status indicator 24
 - submenus 42
 - supply submenu
 - max output current 48
 - max output voltage 47
 - min output current 47
 - min output voltage 47
 - select power supply 44
 - v-v mode range 48
 - system features 1
 - system interconnects 13
 - system name 185
- T**
- terminal torque limits 8, 160
 - test procedure 17
 - torque limit on terminals 8, 160
 - troubleshooting
 - cannot enter persistent mode 140
 - cannot exit persistent mode 140
 - charges slowly 139
 - communication failures 142
 - contacting AMI support 143
 - excessive LHe losses 141
 - magnet current drifts while PSwitch cooling 142
 - no field display 141
 - no power 136
 - operating voltage 12
 - oscillation 138
 - quenches 140
 - replacing the battery 137
 - replacing the Model 430 fuse 136
 - unidirectional current with four-quadrant supply 139
 - voltage selector 137
 - will not charge 138
 - will not discharge 139, 140
 - troubleshooting hints 135
- U**
- unstable power supply 138
- V**
- velocity sensitivity of fine adjust knob 27
- Z**
- zero flux current measurement 1, 3, 10,
13, 22, 159

Index
