



Phoenix

AMI Model 32E
RF Capacitance
Continuous Level Transmitter

INSTALLATION, OPERATION & MAINTENANCE MANUAL



American Magnetics, Inc
112 Flint Road
Oak Ridge, TN 37831

Phone#: (865) 482-1056
Fax#: (865) 482-5472

www.americanmagnetics.com

[mn-32E, Rev 1]
Feb 7, 2007

TABLE OF CONTENTS

SECTION A

<i>Foreword</i>	3 - 4
<i>Introduction</i>	5
System Description	5
Instrument Model Configuration	6
Probe Model Configuration	7
Product Specifications.....	8
Product Approvals.....	9
Operating Principle.....	9
<i>Installation</i>	10
Probe Installation	11
Integral-mounted Transmitters	12 - 13
Remote-mounted Transmitters	14 - 16

SECTION B

<i>Set-up</i>	17
Menu Item Descriptions	18
Menu Structure.....	19 - 20
ProxCal Calculation.....	20
<i>Troubleshooting</i>	21 - 23
General	21
Error Display	21
Drift Test.....	22
System Loop Test	22
Check Probe	22 - 23

APPENDIX A

Dimensional Drawings	24 - 25
Installation Drawings.....	26 - 27

SECTION A

Foreword

Scope

This section contains the Installation instructions for the American Magnetics Phoenix Model 32E Two-Wire Continuous Level Transmitter. Since it is impossible to cover all sensor/systems configurations, only the most common are discussed in this document.

Section Contents

Foreword discusses safety precautions and safety notations as well as other generic information used throughout this manual

Introduction explains the functions and characteristics of the instrument, describes the model number configurations for the instrument and the probe, and documents the performance specifications, and provides an explanation of the operating principle.

Installation describes the procedure for properly unpacking and installing the transmitter into your vessel.

Safety Precautions

Conventions

The conventions used in this manual follow ANSI Z535.4-2002 for "Product Safety Signs and Labels". The safety markings in this manual are as follows:



WARNING indicates a potentially hazardous situation that, if not avoided, could result in death or serious injury.



CAUTION indicates a potentially hazardous situation that, if not avoided, may result in minor or moderate injury. This category also includes potential equipment damage.

Cryogen Safety

Cryogenic liquefied gases are potentially extreme suffocation hazards since a small amount of liquid will vaporize and yield a very large volume of oxygen-displacing gas. Always ensure the location where the cryogen used is well ventilated.

Cryogenic liquids, due to their extremely low temperatures, will burn the skin in a similar manner to hot liquids. Never permit cryogenic liquids to come into contact with the skin or allow them to soak clothing. Serious burns may result from careless handling. Never touch non-insulated pipes or vessels containing cryogenic liquids. Flesh will stick to extremely cold materials. Even nonmetallic materials are dangerous to touch at low temperatures. The vapors expelled during the venting process are sufficiently cold to burn flesh or freeze optic tissues.

Containers of cryogenic liquids are self-pressurizing (as the liquid boils off, vapor pressure increases). Hoses or lines used to transfer these liquids should never be sealed at both ends (i.e. by closing valves at both ends).

The properties of many materials at extremely low temperatures may be quite different from the properties that these same materials exhibit at room temperatures. Exercise extreme care when handling materials cooled to cryogenic temperatures until the properties of these materials under these conditions are known.

Cryogenic storage systems are complex systems with the potential to injure personnel or equipment seriously if not operated according to procedures. Proper use of safety mechanisms (pressure relief valves, rupture disks, etc.) included in the cryostat and top plate assembly are necessary.

Approvals

FM (Factory Mutual) Approvals were originally authorized for the Model 32E Phoenix and associated industrial probes (as described in this manual) for manufacture by American Level Instruments (ALI), a Division of American Magnetics, Inc. (AMI). ALI is no longer in business and, in 2006, FM formally authorized the name change to the parent company, AMI, for all existing approvals. All drawings were “grandfathered without the need or authorization to change the existing drawings, and hence the appearance of the American Level Instruments name and Logo on the FM-Controlled drawings (pages 26 – 27 of this manual). Note: The C3x style probes referenced in the drawings have been discontinued.

Warranty

American Magnetics warrants its products to conform to the specifications described in its quotation for a period of fifteen months from the date of shipment. AMI makes no other warranty of any kind, expressed or implied. In the event of failure occurring during normal use, AMI will, at its option, repair or replace all products or components that fail under warranty and such repair or replacement shall constitute a fulfillment of all AMI liabilities with respect to its products. Since, however, AMI does not have control over the installation conditions or the use to which its products are put, no warranty can be made of fitness for a particular purpose, and AMI cannot be liable for special or consequential damages. All repairs are F.O.B. Oak Ridge, Tennessee, USA. If the repairs are covered under this warranty, standard shipping for return to customers within the USA is paid for by AMI. Customers requiring a more comprehensive warranty program may purchase additional coverage, the price of which may vary by product.

Return Authorization

Before shipping any item to AMI for repair, the customer must first obtain an RMA number from an authorized AMI representative. Do not attempt to repair or replace any items without first speaking to an authorized AMI representative. Doing so may expose the customer to hazards and will void this warranty.

Introduction

The instructions in this manual pertain to the American Magnetics Phoenix Model 32E Two-Wire Continuous Level Transmitter. The Phoenix is designed to measure the level of many liquids, slurries, liquid-liquid interfaces, or cryogenic fluids compatible with stainless-steel and Teflon[®] constructed probes.

The Phoenix is available in two different mounting configurations. The first is integral-mounting with the probe (see Photo #1). The second is remote-mounting, a maximum of 10 feet from the probe (Photo #2).

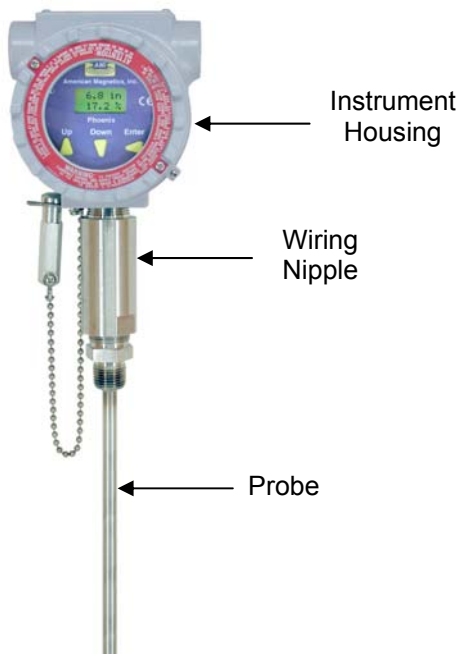

Photo #1

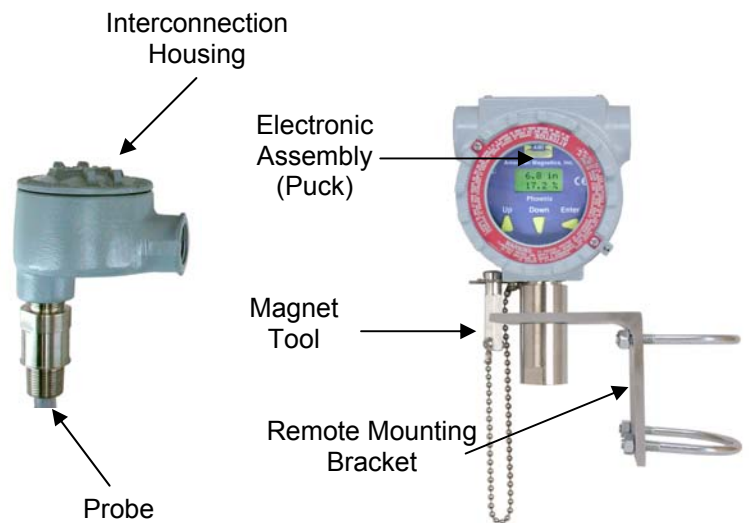

Photo #2

System Description

The Model 32E liquid level system consists of the Model 32E Instrument and an Industrial style probe. The instrument consists of the electronics assembly (puck), a NEMA 4X / 7 explosion-proof enclosure, and an interconnection nipple. The enclosure provides (2) 3/4" NPT conduit openings for wiring. The "window" cover allows for viewing of process variables. A magnet tool provides a way to set-up and calibrate the instrument without removing the cover. The various available probe assemblies are designed to electrically and physically mate to the Model 32E, either directly or remotely (up to 10-feet).

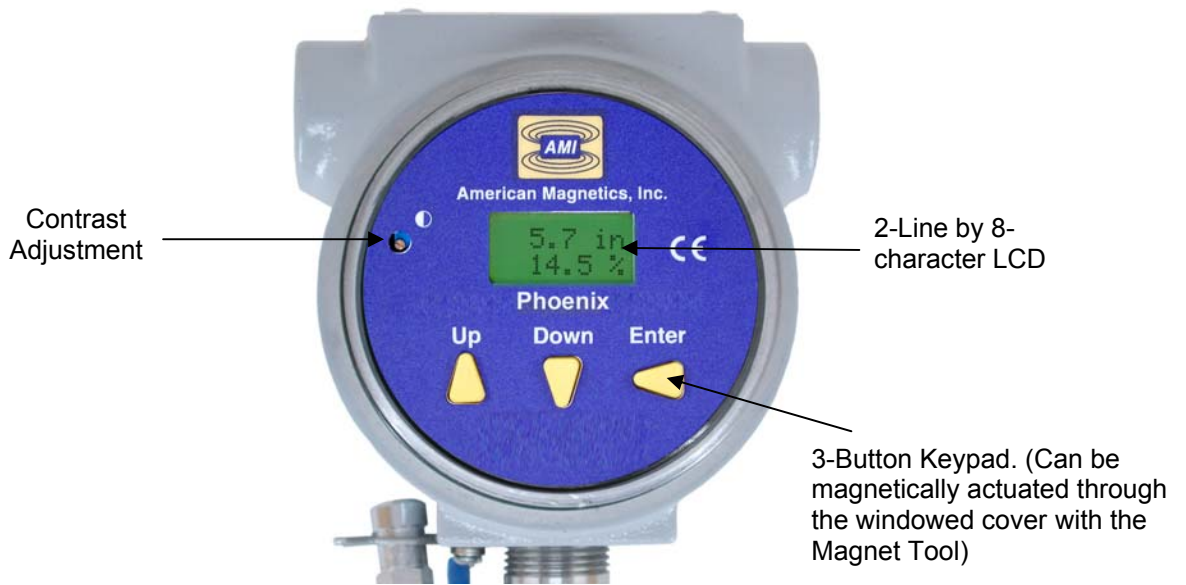
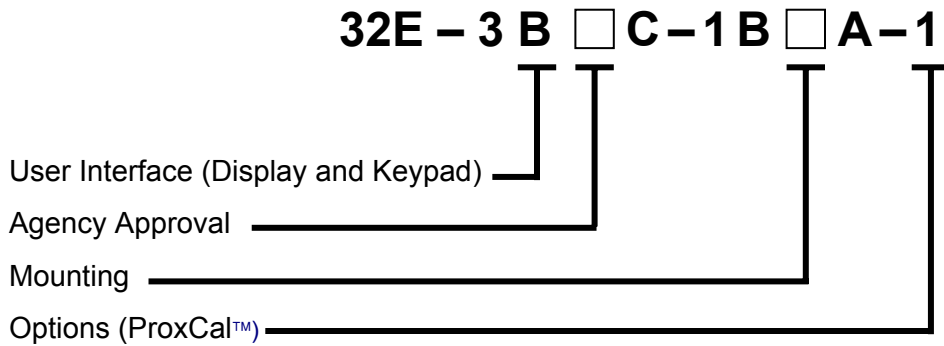

Photo #3

Probe: There is a myriad of probe configurations available for many process level measurement applications compatible with stainless-steel and Teflon[®] constructed probes. A wide variety of threaded and flanged connections is available.

Instrument Model Configuration



User Interface

Description	Code
Onboard display & keypad	B

Mounting

Description	Code
Integral	0
Remote	1

Agency Approval*

Description	Code
FM Intrinsically Safe (I.S. & N.I.) for use with any probe	2
**FM Explosion Proof (XP, I.S. & N.I.) for use with C2x	3

Options

Description	Code
ProxCAL™	1

*Selected Approval must match that of Probe (see page 9).

**Maximum Ambient Temperature for XP Installations: 140°F (60°C).

Probe Model Configuration

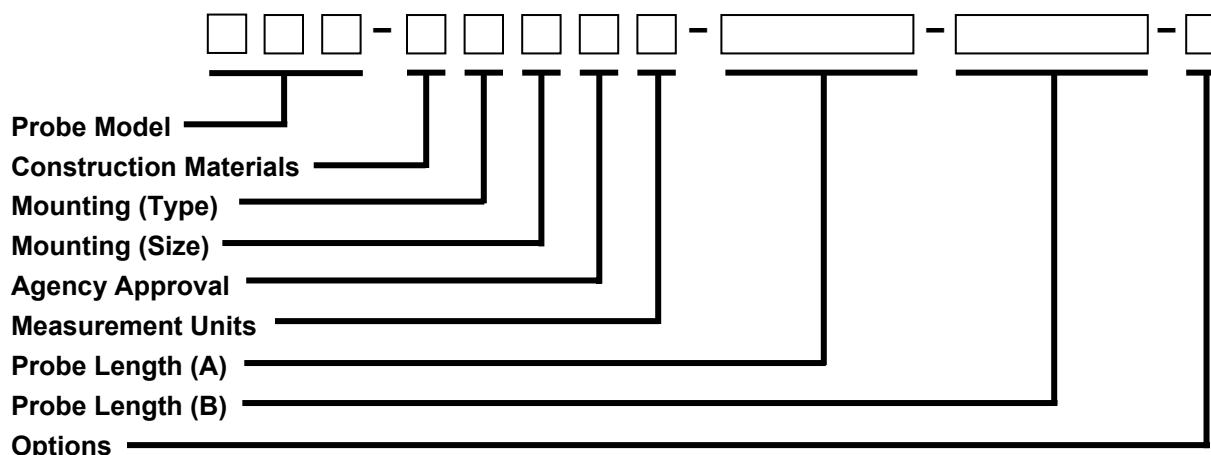

Probe Model

Description	Code
Bare Rod	C1A
Bare Stillwell	C1D
Bare Bent Rod	C1F
Insulated Rod	C2A
Insulated Inactive Sheath	C2B
Insulated Reference Wire	C2C
Insulated Stillwell	C2D
Insulated Bent Rod	C2F
Cryogenic Liquid	C4A
Liquid Hydrogen (Cryogenic)	C4H
Liquid Oxygen (Cryogenic)	C4J

Construction Materials

Description	Code
316 SS (C1x)	0
304 SS (C4x)	7
316 SS w/ Teflon® (C2x)	A

Mounting Type

Description	Code
NPT	A
150# ANSI Flange	B
300# ANSI Flange	C
600# ANSI Flange	D
Sanitary Fitting (C2A)	E
Conflat (C4x)	1

Mounting Size

Description	Code
1/2" (ANSI Flange), (NPT – C4A & C4J)	A
1.33" (Conflat)	B
2-1/8" (Conflat)	C
2-3/4" (Conflat)	D
3/4" (ANSI Flange & NPT)	0
1" (ANSI Flange, NPT, & Sanitary)	1
1-1/2" (ANSI Flange, NPT, & Sanitary)	5
2" (ANSI Flange, NPT, & Sanitary)	2
3" (ANSI Flange & NPT)	3
4" (ANSI Flange & NPT)	4
6" (ANSI Flange & NPT)	6
8" (ANSI Flange & NPT)	8

Agency Approval*

Description	Code
FM Intrinsically Safe (I.S. & N.I.) - All Probes	2
FM Explosion Proof (XP, I.S., & N.I.) - C2x Probes only	3

Measurement Units

Description	Code
Inches	0
Feet	1
Millimeters	2
Meters	3

Options

Description	Code
None	0
Seal Welding (ANSI Flanges)	1

* Selected Approval must match that of Instrument (see page 9).

Probe Length (A)

This field represents the insertion length of the probe, which is defined as the length of the probe, measured from the bottom probe tip to the bottom of the mounting connection. Probes are available in lengths up to 234". For C4x probes, the minimum insertion length is Probe Length (B) + 2.375". For CxF probes this is the 'A' dimension. Probe length fields are fixed as follows: xxx.x inches, xxx.x feet, xx.xx meters, and xxxxx millimeters. Use leading zeros if necessary to supply all five characters (the decimal point counts as a character).

Probe Length (B)

This dimension is used for C2B, CxF, and C4x probes only. For C2B probes this is the length of the inactive sheath. For the CxF probes, this is the 'B' dimension. The maximum length is limited by the formula: 'A' dim. + 'B' dim. + 3" ≤ 234". For C4x probes, this field represents the Active Length, which is defined as the measurement range of the probe. It starts 0.375" above the bottom tip of the probe, and ends 1" below the upper-most vent hole on the probe. Probe length fields are fixed as follows: xxx.x inches, xxx.x feet, xx.xx meters, and xxxxx millimeters. Use leading zeros if necessary to supply all five characters (the decimal point counts as a character). For probes not using this field, fill this space with zeros, using the applicable length format from Probe Length (A).

Specifications

Loop Resistance Chart

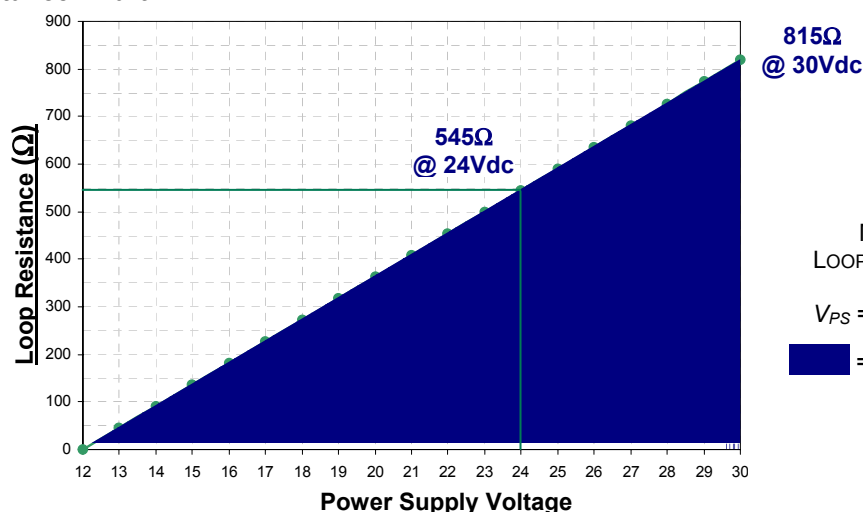

$$\text{MAXIMUM LOOP RESISTANCE} = \frac{V_{PS} - 12}{0.022}$$

V_{PS} = Power Supply Voltage

■ = Acceptable Loop Resistance Range

Instrument

Description		Specification
Power Supply		12 – 30Vdc \pm 10%; 24Vdc nominal
Supply Voltage Effect		Less than 0.01% of span/volt change
*Ambient Temperature Range		-40°F to 176°F (-40°C to 80°C)
Humidity		100% condensing
Accuracy		\pm 0.1% of span
Repeatability		\pm 0.05% of span
Linearity		\pm 0.1% of span
Resolution		0.01mA
Response Time		300 msec.
Temperature Effect		\pm 0.01% of span/°F (0.018% of span/°C)
Operator Interface	Data Entry	3-button keypad; Magtouch™
	Display	2 Line by 8 Character LCD
Analog Output		4-20mA; 3.8 – 20.5mA overtravel; reversible
Error Indication		3.6mA, 22mA, or Hold last value; field selectable
Range		15 – 100,000pF
Damping		0 – 60 seconds; field adjustable in 1 sec. increments
Maximum Remote Cable Length		10 feet between the transmitter and the probe.

* Maximum Ambient Temperature of 140°F (60°C) for XP Installations

Probe

Description		Specification
Process Temperature Range @ 1 psig (1 Bar)	C1x	-100°F – 400°F (-73°C – 204°C)
	C2x	-100°F – 400°F (-73°C – 204°C)
	C4A	-430°F – 180°F (-257°C – 82°C)
	C4H	-430°F – 250°F (-257°C – 121°C)
	C4J	-430°F – 400°F (-257°C – 204°C)
	Process Pressure Range @ 100°F (37°C)	C1x
C2x		Vacuum to 2,000 psig
C4x		Vacuum to 1,000 psig

Approvals*

Instrument

Agency	Models	Protection Method	Approval
Factory Mutual (FM)	32E-3B3C-1BxA-1	**Explosion-proof (XP, I.S. and N.I.)	Division 1 Class I – Groups B, C, D
	32E-3B2C-1BxA-1 32E-3B3C-1BxA-1	Intrinsically Safe and Non-Incendive (I.S. and N.I.)	Division 1 and Division 2 Class I – Groups A, B, C, D

Probes

Agency	Models	Protection Method	Approval
Factory Mutual (FM)	C2x-xxx3x-xxxxx-xxxxx-x	**Explosion-proof (XP, I.S. and N.I.)	Division 1 Class I – Groups B, C, D
	Cxx-xxx2x-xxxxx-xxxxx-x C2x-xxx3x-xxxxx-xxxxx-x	Intrinsically Safe and Non-Incendive (I.S. and N.I.)	Division 1 and Division 2 Class I – Groups A, B, C, D

* Class II and Class III applications are no longer supported.

Two available approval combinations:

1. All probes are Approved for Intrinsically Safe and Non-Incendive (I.S. and N.I.) applications.
2. In addition, C2x probes are Approved for Explosion Proof, i.e., XP, I.S., and N.I. applications.
3. Customer is responsible for determining required level of approval.

**The maximum ambient temperature for Explosion-proof installations is 140°F (60°C).

Operating Principle

For non-conductive media applications in metallic vessels, the probe in conjunction with the vessel wall and the process media form a capacitor. The probe and the vessel walls are the plates of the capacitor and the media is the dielectric. As the level of the media changes, a corresponding change in capacitance occurs. The Phoenix transmitter measures this change, compares it to the calibrated values and calculates the level of the media.

For conductive media applications in metallic vessels, the probe and the process media are the capacitive plates and the insulation (Teflon®) on the probe is the dielectric.

When measuring any media in non-metallic vessels (concrete sumps, plastic tanks, etc.) the second plate of the capacitor must be supplied. AMI offers a variety of options for this situation.

Installation

Unpacking

Upon receiving the Phoenix transmitter, check all components carefully for damage incurred in shipping. If damage is evident, or suspected, do not attempt installation. Notify the carrier immediately and request a damage inspection. Check each item against the packing list.

Mounting Location

Phoenix transmitters should be mounted in a location that is as free as possible from mechanical shock, vibration, and corrosive atmospheres. The area should have an ambient temperature in the range of -40°F to 176°F (-40°C to 80°C). NOTE: 140°F (60°C) is the maximum ambient temperature for XP installations.

In many applications, the metallic vessel wall is the second plate of the capacitor (typically referred to as the ground reference). For the transmitter to function properly the probe's mounting connection must make good electrical connection with the vessel. This usually occurs by metal-to-metal contact between the mounting and the vessel connection threads, or via the metallic bolts used with mounting flanges. However, rust, Teflon tape, gaskets, and paint can interfere with obtaining a solid electrical contact. If you are unsure, about the quality of this connection, a grounding strap between the probe's mounting nut and the vessel is recommended.

Metallic Vessels / Non-conductive Media: Mounting the probe as close as possible to the vessel wall will enhance resolution and linearity. If the distance is greater than 10" or if the vessel is a horizontal cylinder or sphere, a stilling well is recommended.

Metallic Vessels / Conductive Media: These are usually the simplest of all applications. Ensure that you are using an insulated probe. Since the media itself is the ground reference, distances to the vessel wall and vessel shape are not factors.

Non-metallic vessels / Any Media: Either you must use a metal stilling well or an AMI probe with ground-reference.

If you have any questions concerning the probe selection for a given application, contact AMI Sales for assistance.

Probe Installation



The gland used on the probes is factory adjusted and sealed. Any attempt at disassembly will permanently damage the probe.

Verify that the process conditions do not exceed the probe's specification (see page 9 for specifications).

- 1.) Carefully insert the probe through the mounting connection into the vessel (see Photo #4). When using the NPT fitting, sealing tape or pipe joint compound can be used around the threads of the probe-mounting nut to obtain a good seal without excessive tightening.
- 2.) Screw the probe into the vessel using the wrench flats provided on the mounting nut. Insure that there is a good electrical connection (1Ω or less) between the mounting nut and the vessel.
- 3.) Attach the supplied probe wire to the screw terminal at the top of the probe. In the case of a cryogenic probe (C4A, C4H, or C4J) the connection is a BNC instead of a screw terminal.

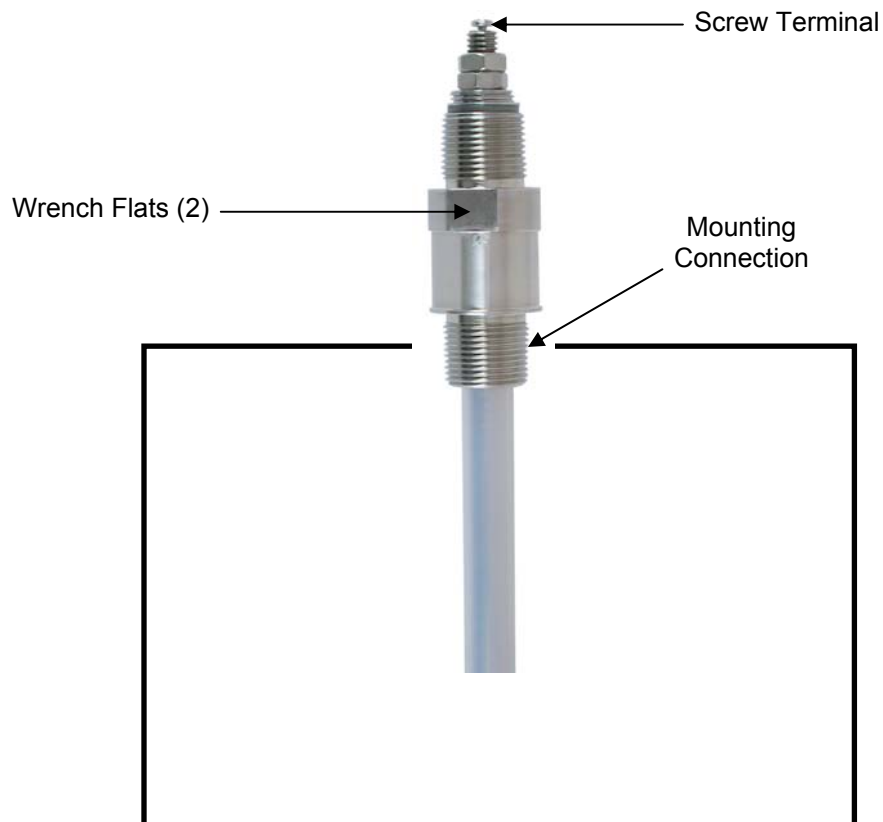

Photo #4

Integral-mounted Transmitter Installation

Before starting installation procedures in hazardous areas, insure that all power sources have been turned off and locked out. "Live" electrical circuits can ignite flammable gasses and dusts.



Follow the wiring practices set forth in the National Electric Code, as well as local electrical codes. These Codes supercede any information in this manual.



Do not apply loop power until all connections have been completed and checked. Do not apply more than 33Vdc to the transmitter, as this may damage the instrument.

- 1.) Remove the cover from the instrument enclosure.
- 2.) Remove the electronic assembly (puck) from the instrument enclosure. Hold the puck firmly around the diameter and pull it out of the enclosure. No tools are necessary.

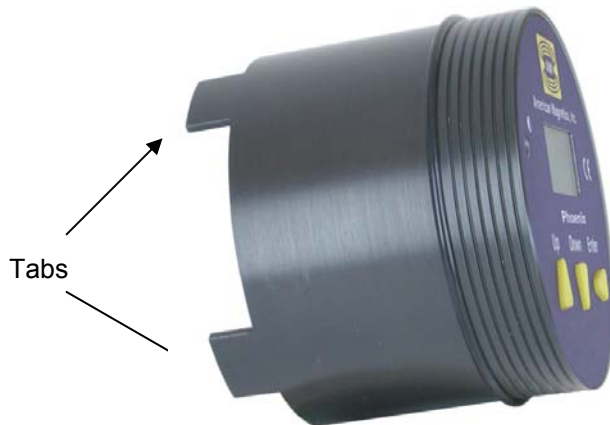

Photo #5

- 3.) The wiring nipple is attached to the instrument enclosure at the factory (see Photo #1 on page 5). Thread the probe wire up through the wiring nipple. Screw the wiring nipple onto the top of the probe. Use the wrench flats provided on the probe and the wiring nipple to tighten. **DO NOT use the instrument enclosure for tightening.**
- 4.) Use an ohmmeter to verify that the resistance between the probe wire and the nipple is at least 40Meg Ω .
- 5.) Connect the probe wire to the PROBE terminal in the base of the instrument enclosure (see Photo #6). If you are using a cryogenic probe, the probe wire is an RG-188 coax cable with a female BNC Connector on one end. The center wire goes to the PROBE terminal, and the shield connects to the ground terminal. Ensure the probe wire is under the cable stay.

- 6.) Install a conduit fitting to one of the conduit openings at the top of the instrument enclosure. Use the supplied conduit plug for the unused conduit opening. Follow all applicable electrical codes when installing this conduit. It is strongly recommended that you use a drip-loop to prevent water from entering the instrument enclosure from the conduit.

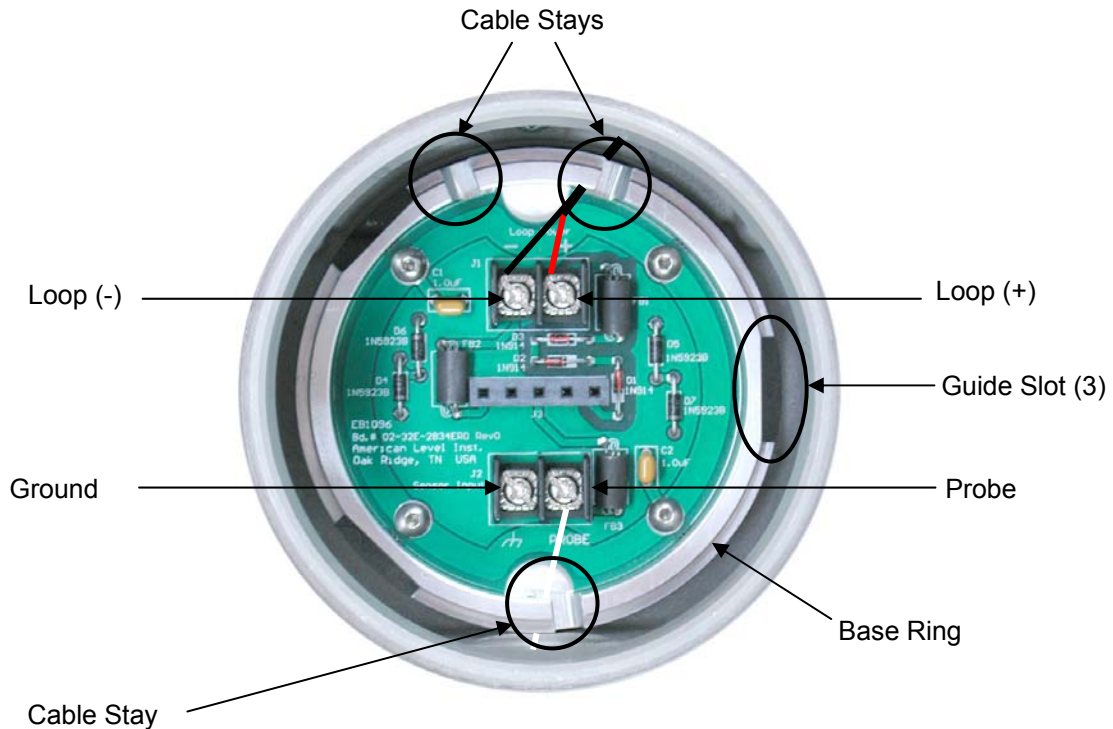

Photo #5

- 7.) Using a twisted shielded pair cable, connect the positive wire to the Loop (+) terminal and the negative wire to the Loop (-) terminal. At the power supply end, also connect the shield and/or drain wire to ground. **DO NOT connect the shield and/or drain wire to the transmitter.** Connect an earth ground wire to the green screw inside the Instrument Enclosure.
- 8.) Reinsert the puck into the instrument enclosure by visually aligning the tabs (3) on the puck (see Photo #5 on page 12) with the three guide slots in the base ring, using firm pressure to seat the puck. **DO NOT FORCE** - it can only fit in one orientation.
- 9.) If this is an Intrinsically Safe installation, make sure that the I.S. Barrier is properly installed in the "Safe" area before applying power to the Phoenix Transmitter. Follow Plant, Local, and National Electric Codes to insure safe operation.
- 10.) Refer to Section B for calibration and programming instructions.

Remote-mounted Transmitter Installation

Before starting installation procedures in hazardous areas, insure that all power sources have been turned off and locked out. "Live" electrical circuits can ignite flammable gasses and dusts.



Follow the wiring practices set forth in the National Electric Code, as well as local electrical codes. These Codes supercede any information in this manual.



Do not apply loop power until all connections have been completed and checked. Do not apply more than 33Vdc to the transmitter, as this may damage the instrument.

- 1.) Remove the cover of the interconnection housing.

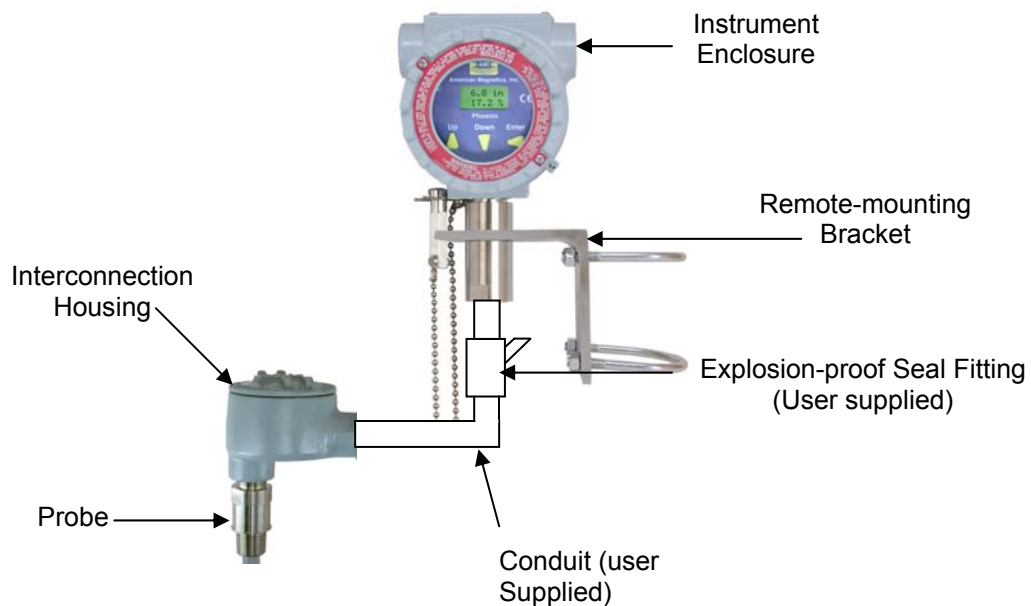

Photo #7

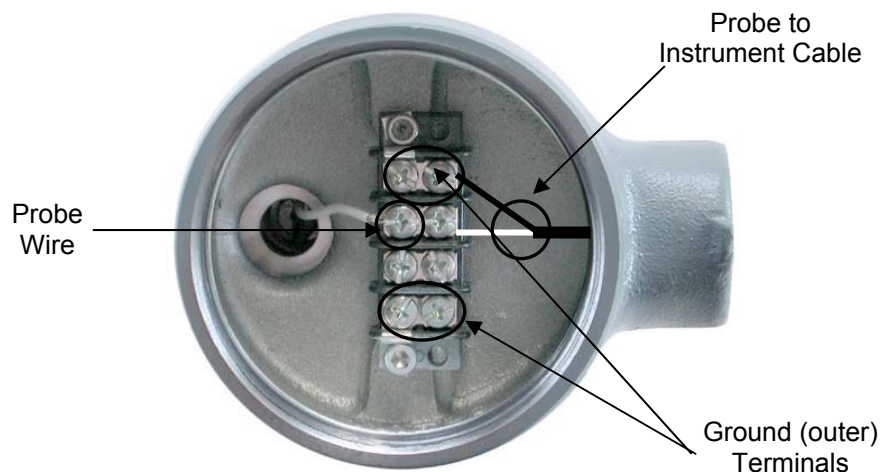

Photo #8

- 2.) Look at the wire at the top of the probe. Cryogenic probes have a RG-188 coaxial cable with a BNC connector at the probe, and two wires (center & shield) at the other end.

NOTE: All other probes have a single wire from the screw at the top of the probe. This single wire (the center wire on Cryogenic probes) is considered the “probe” wire for the remainder of these instructions.

- 3.) Unscrew the nipple from the bottom of the instrument enclosure. If the process temperature exceeds 176° F (80°C), screw the nipple onto the top of the probe, being careful to thread the probe wire through the nipple. Use an ohmmeter to verify that the resistance between the probe wire and the nipple is at least 40MegΩ.

NOTE: If the process temperature is less than 176°F (80°C), you may discard the nipple. Thread the probe wire into the bottom of the interconnection housing. Screw the interconnection housing onto the top of the probe.

- 4.) Connect the probe wire to the terminal block inside the Interconnection Housing (see Photo #8 on page 14). If this is a cryogenic probe, connect the shield wire to one of the two outer ground terminals.
- 5.) Remove the cover from the instrument enclosure.
- 6.) Remove the electronic assembly (puck) from the instrument enclosure (Photo #5 on page 12). Hold the puck firmly around the diameter and pull it out of the enclosure. No tools are necessary.
- 7.) Using the U-Bolts provided, attach the remote-mounting bracket to a pipe stand or railing. The U-Bolts are sized for a 2" diameter pipe.
- 8.) Connect conduit between the interconnection housing and the remote-mounting bracket (see Photo #7 on page 14). See the installation drawings in Appendix A as a reference to determine the correct location of the XP seal fitting (needed for an Explosion-proof installation; not needed for an Intrinsically Safe installation). It is strongly recommended that you use a drip-loop to prevent water from entering the instrument enclosure or interconnection housing from the conduit.
- 9.) In the Interconnection Housing, using a twisted shielded pair cable, connect one wire (designated “probe” wire) to the screw terminal opposite the probe wire, and the other wire to either of the outer (ground) terminals (see Photo #8 on page 14 for reference – the black wire is shown connected to the ground terminal). Clip the shield/drain wire short (**DO NOT** connect it to anything).
- 10.) In the instrument enclosure, connect the probe wire to the “PROBE” terminal in the base of the instrument enclosure (see Photo #6). Connect the ground wire to the ground terminal (not the green screw). Connect the shield/drain wire to the green screw at the bottom of the enclosure.

- 11.) Connect conduit to one of the two conduit openings at the top of the instrument enclosure. Use the supplied conduit plug for the other conduit opening. Follow all applicable electrical codes when installing this conduit and wire. It is strongly recommended that you use a drip-loop to prevent water from entering the instrument enclosure from the conduit.
- 12.) In the instrument enclosure, using a twisted shielded pair cable, connect the positive wire to the Loop (+) terminal and the negative wire to the Loop (-) terminal. Place the wires under one of the two cable stays in the bottom of the enclosure (see Photo #6 on page 13). At the power supply end, also connect the shield and/or drain wire to ground. **DO NOT** connect the shield and/or drain wire to the transmitter, as this could cause an unwanted "ground loop" situation. Connect an earth ground wire to the green screw inside the Instrument Enclosure.
- 13.) Reinsert the puck into the instrument enclosure by visually aligning the three tabs on the puck (see Photo #5 on page 12) with the guide slots in the base ring. Use firm pressure to seat the puck. **DO NOT FORCE** - it can only fit in one orientation.
- 14.) If this is an Intrinsically Safe installation, make sure that the I.S. Barrier is properly installed in the "Safe" area before applying power to the Phoenix Transmitter. Follow Plant, Local, and National Electric Codes to insure safe operation.
- 15.) Refer to Section B for calibration and programming instructions.

SECTION B

Scope

This section contains the Operation and Maintenance instructions for the American Magnetics Phoenix Model 32E Two-Wire Continuous Level Transmitter. Since it is impossible to cover all possible sensor/systems configurations, only the most common are discussed in this document. The user is encouraged to contact AMI Customer Support for specific situations.

Section Contents

Set-up details the software commands and procedures for matching (calibrating) the transmitter to your particular sensor and application.

Troubleshooting provides information and various tests used to determine the cause of issues with the Phoenix transmitter.

Set-Up

The Phoenix Transmitter displays information locally in a 2-line by 8-character format. The normal operating display can be set to either LEVEL & %OUTPUT, or LEVEL & LOOP CURRENT. The keypad consists of three buttons. "Up" and "Down" are used to scroll through the menu or change the numeric value of a particular option. Depress either of the buttons continuously to rapidly change the numeric value. "Enter" is used to accept the data that has been selected with the "Up" and "Down" buttons.

The buttons can be actuated through the glass window in the cover using the supplied Magnet Tool. It is not necessary to remove the cover to set-up this transmitter.

Menu Item Descriptions

FUNCTION	DESCRIPTION
Units	Used to select the measurement units shown on the display. These units are used during the calibration process.
Hi Cal	For setting the high calibration point on the probe. This can either be the highest liquid level on the probe (preferably), or the highest achievable level during calibration. The order in which the “Lo Cal” and “Hi Cal” are set is not important, but the “Lo Cal” must be below the “HiCal”. A minimum of 2% span change is required between the two points. These points are independent of the 4mA / 20mA points.
Lo Cal	This is used to set the low calibration point on the probe. This can either be the lowest liquid level on the probe (preferably), or the lowest achievable level during calibration. The order in which the “Lo Cal” and “Hi Cal” are set is not important, only that the “Lo Cal” is below the “Hi Cal”. A minimum of 2% span change is required between the two points. These points are independent of the 4mA & 20mA points.
20 mA Pt	Levels in the vessel corresponding to the 4mA and 20mA outputs. They will usually be different from the “Lo Cal” & “Hi Cal” points.
4 mA Pt	
Prox Cal	After the unit has been calibrated for a particular fluid, “ProxCal” will allow you to adjust the calibration for a different fluid without changing the level in the vessel. The “Hi Cal” and “Lo Cal” points must not be changed when using ProxCal. If you recalibrate the transmitter in the new fluid, change the ProxCal value back to 100.0
Damping	An exponential decay filter used to slowdown the output response time of the transmitter. This, in effect, stabilizes the output and display in a turbulent vessel.
Error	Determines the value of the output current upon detection of a fault condition (capacitance out of range, dead oscillator, loss of signal, etc.).
Trim 20	Allows for an adjustment of the D/A converter for the 4-20mA output, to ensure the unit display matches the actual 4-20mA signal. (as measured with a mA meter).
Trim 4	
Poll Adr	Not used.
Loop Cur	Allows the user to set the transmitter output to a fixed value from 3.6 to 22mA (for test purposes).
RNG:CNTS	RNG displays the calibration range (0 to 7). The transmitter automatically selects the Range value during the calibration process. 0 = 0 to 781pF 3 = 0 to 6,250pF 6 = 0 to 50,000pF 1 = 0 to 1,562pF 4 = 0 to 12,500pF 7 = 0 to 100,000pF 2 = 0 to 3,125pF 5 = 0 to 25,000pF CNTS displays the digital counts that correspond to the capacitance being measured within the Range selected (Troubleshooting tool). 0 to 65,535 counts within each range.
Clr Mem?	Erases all values in the transmitter, and resets them back to factory default values. Recalibration is required if “Clr Mem?” is used.

Menu Structure

Description

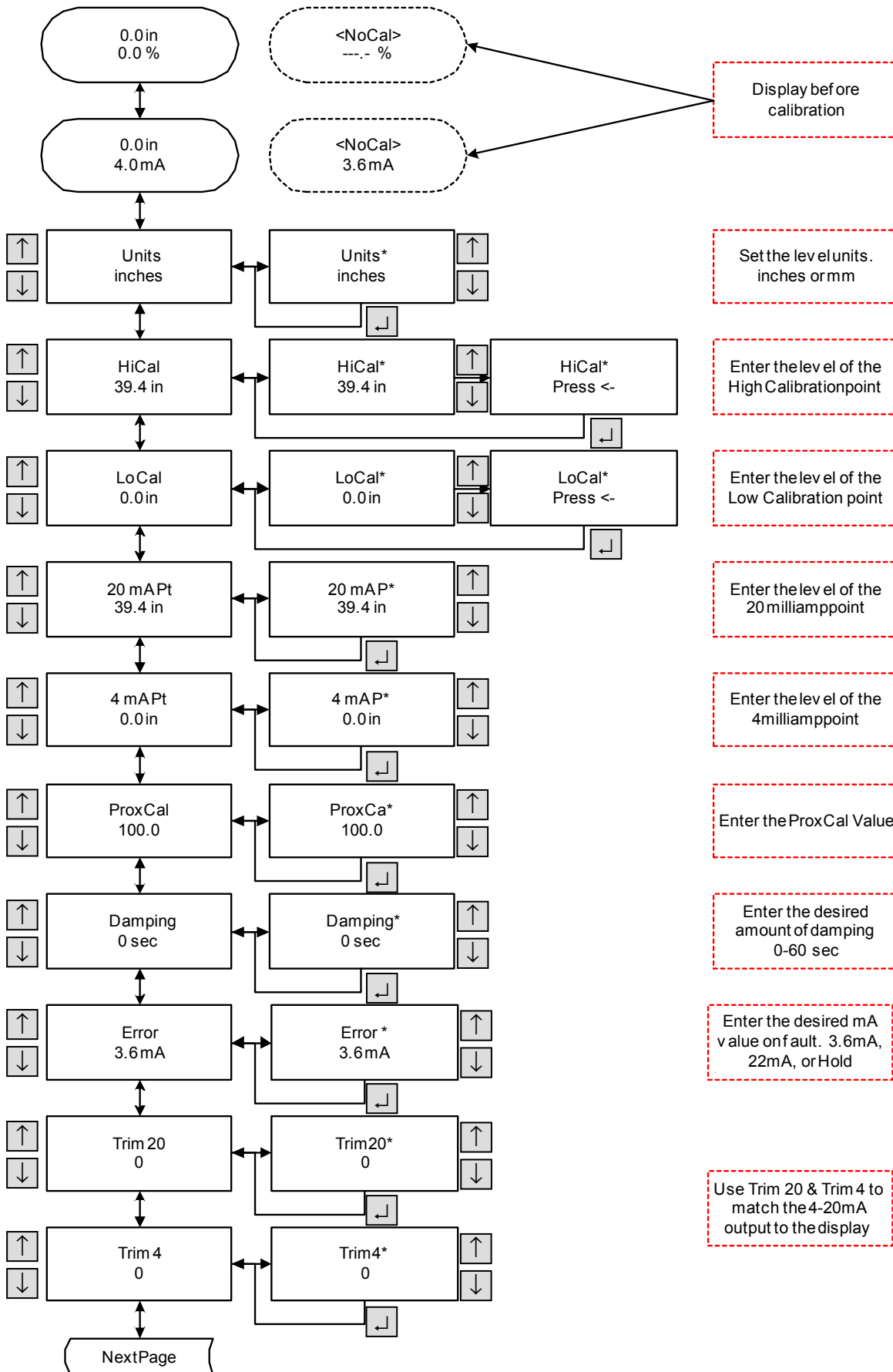

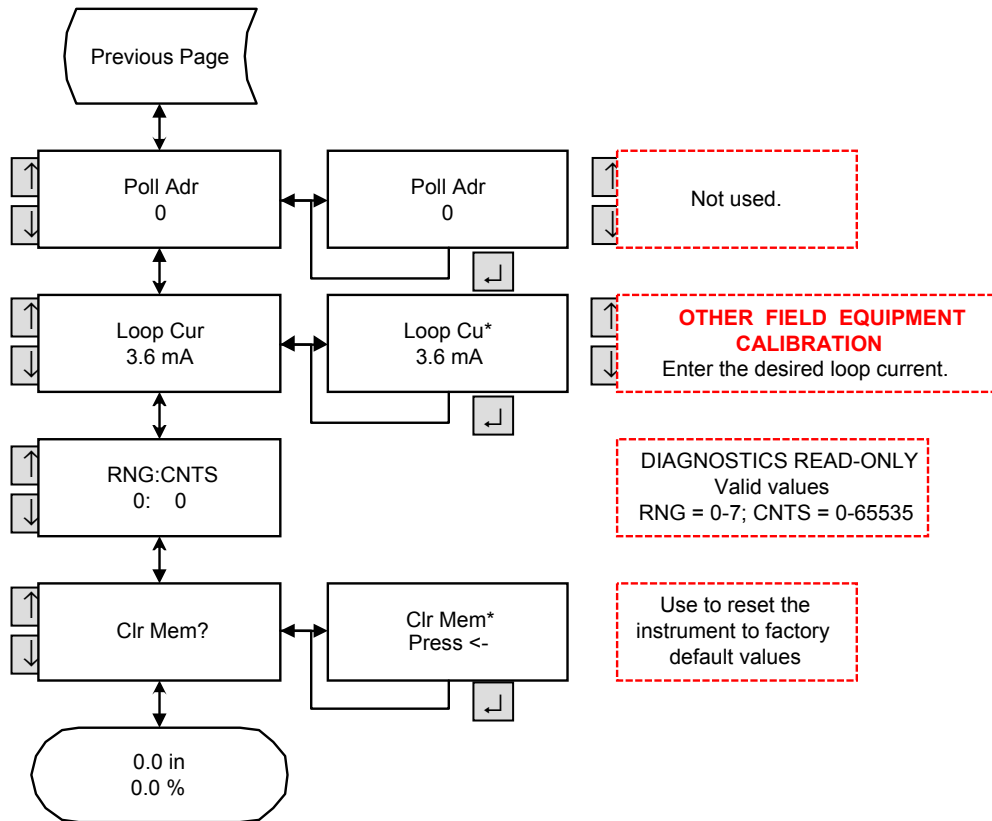

ProxCal Calculation

This method is the least accurate form of calibration and should be used only when it is impossible to change the level of the process fluid. This method requires a substitute *low dielectric, low conductivity* fluid to be used for calibration. A cryogenic or stilling well probe must be used if the actual process vessel is not available for the calibration process.

To use ProxCal, the level measurements used for Probe LO and Probe HI must be referenced from the tip of the probe (probe bottom). In other words the probe bottom must be considered zero (inches or mm).

The dielectric constant for the reference (substitute) fluid ϵ_1 , and the target (process) fluid ϵ_2 are needed for the ProxCal factor calculation. The equation is as follows:

$$\text{ProxCal Factor} = \frac{\epsilon_2 - 1}{\epsilon_1 - 1} \times 100$$

Install the transmitter into the target vessel containing the process fluid. Go to the "Menu Structure" section for directions on how to enter the ProxCal factor into the transmitter.

If you do not know the dielectric constant of the fluids, obtain the actual level of the process fluid in the target vessel. Install the transmitter into the target vessel. Adjust the ProxCal factor until the transmitter displays the level in the vessel obtained previously.

Troubleshooting

General

Indication	Cause	Solution
No display with power applied	Wiring is reversed	Make sure that the positive side of the power supply is connected to the (+) terminal in the instrument, and that the negative side is connected to the (-) terminal. If you have a negative power supply, reverse the wiring.
Level, Level %, and Loop values are incorrect	Poor Calibration	Recalibrate using more accurate Cal Points. Increase the distance between the Cal Points.
Level readings are repeatable, but consistently wrong.	Poor Calibration	Recalibrate using more accurate Cal Points. Increase the distance between the Cal Points.
Display values “bounce”	Turbulence	Adjust the Damping value. Increase it until the display is stable.

Error Display

Indication	Cause	Solution
EEPROM failure	Bad Checksum	Press “Up” & “Down” simultaneously, and hold until the display changes. This will completely reset the transmitter back to factory default values. Recalibration will be necessary. If this occurs again contact the factory.
<No LO>	The LO Cal point has not been set	Calibrate the LO Cal point
<No HI>	The HI Cal point has not been set	Calibrate the HI Cal point
<No Cal>	The transmitter has not been calibrated	Calibrate the transmitter
Over (output is greater than 20.5mA)	The capacitance measured is greater than the cal Range	Increase the 20mA Pt value
Under (output is less than 3.8mA)	The capacitance measured is less than the cal Range	Decrease the 4mA Pt value
	Open Probe	Check the wiring between the Probe terminals in the Instrument housing and the Probe
No Input	Shorted Probe	Test the Probe using the procedure shown in the “Check Probe” section.
	Shorted Probe Wiring	Check the wiring between the Probe terminals in the Instrument housing and the Probe



“Live” electrical circuits can ignite flammable gasses and dusts. Insure that the unit is properly grounded, and that a suitable intrinsically safe barrier has been installed between the Power Supply and this unit.

Drift Test

This test will determine if the transmitter or probe/application is the cause of a drifting (unstable) output.

- 1.) Open the instrument housing and remove the electronic “puck”.
- 2.) Disconnect the probe wiring from the terminals on the base board (see Photo #6 on page 13).
- 3.) Connect a temperature stable (COG-type) 200pF capacitor between the “Probe” and ground terminals.
- 4.) Observe the output over a 24-hour period. Check for stability.
- 5.) If the reading has drifted, contact the factory. If the reading is stable either the probe or the application must be the cause. Go to the “Check Probe” section to test the probe. If the probe is OK, contact the factory for application assistance.



“Live” electrical circuits can ignite flammable gasses and dusts. Insure that the unit is properly grounded, and that a suitable intrinsically safe barrier has been installed between the Power Supply and this unit.



Always turn off loop power when connecting and disconnecting loop wires. Check connections before re-applying power

System Loop Test

This test will determine if the correct voltage is available for the transmitter.

- 1.) Disconnect the loop wires from the transmitter (see Photo #6 on page 13).
- 2.) Use a voltmeter to measure the open circuit voltage of the loop. The value must be between 12 and 30 Vdc.
- 3.) Reconnect the loop wires to the transmitter.
- 4.) Use a voltmeter to measure the voltage at the Loop (+) and Loop (-) terminals. The value must be between 12 and 30 Vdc.
- 5.) If you don't get these values, contact the factory for assistance.



“Live” electrical circuits can ignite flammable gasses and dusts. Insure that power has been removed from the unit before performing this test.

Check Probe

This test will determine whether the probe is functional

Integral-mounted Units

- 1.) Open the instrument housing and remove the electronic “puck”.
- 2.) Disconnect the probe wiring from the terminals on the base board (see Photo #6 on page 13).
- 3.) Unscrew the Instrument Housing / Wiring Nipple assembly from the probe.

- 4.) Lower the process fluid level below the bottom of the probe. If this is not possible, remove the probe from the process vessel. DO NOT remove any coating or residue present on the probe.
- 5.) Ensure the probe is clean and use an ohmmeter to verify that the resistance between the screw terminal at the top of the probe and the probe mounting nut is at least 40Meg Ω . If you have a Cryogenic Probe, there is no screw terminal - measure from the center of the BNC Connection at the top of the probe.
- 6.) If the resistance is below 40Meg Ω wipe any coating or residue off the probe, and repeat the measurement. If the reading is still below 40Meg Ω contact the factory.

Remote-mounted Units

- 1.) Open the interconnection housing.
- 2.) Disconnect the probe wiring from the terminal block (see Photo #8 on page 14).
- 3.) Lower the process fluid level below the bottom of the probe. If this is not possible, remove the probe from the process vessel. DO NOT remove any coating or residue present on the probe.
- 4.) Ensure the probe is clean and use an ohmmeter to verify that the resistance between the screw terminal at the top of the probe and the probe mounting nut is at least 40Meg Ω . If you have a Cryogenic Probe, there is no screw terminal - measure from the center of the BNC Connection at the top of the probe.

APPENDIX A

Phoenix (Model 32E) Transmitter Dimensions – inches (mm)

Integral-mounted Transmitters

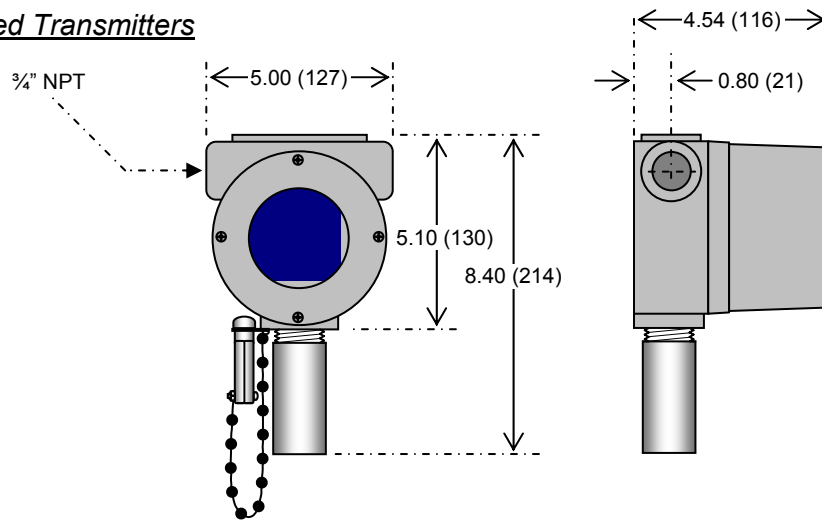

Remote-mounted Transmitters

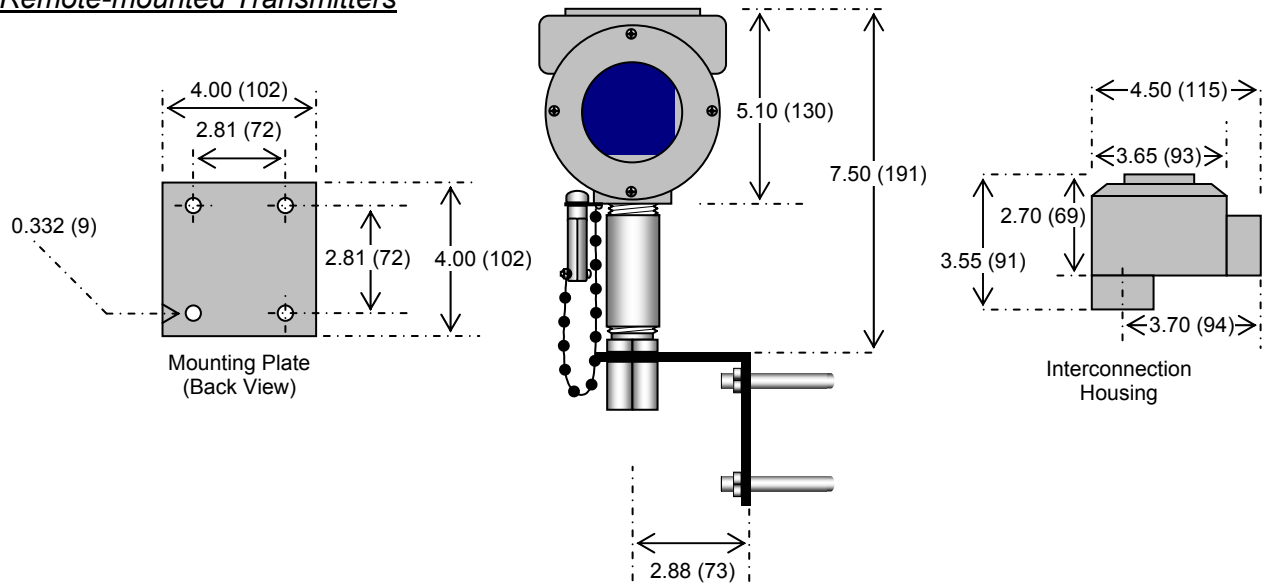

Probe Dimensions – inches (mm)

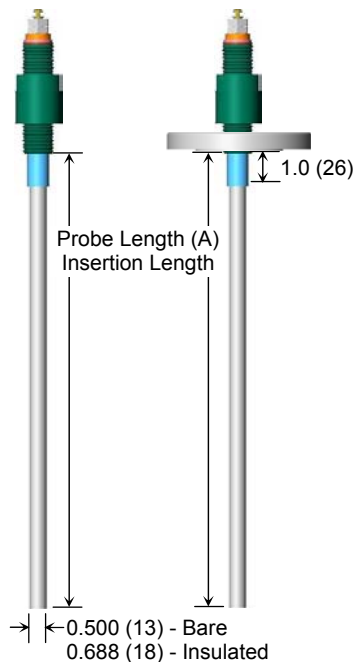

Bare & Insulated Probes

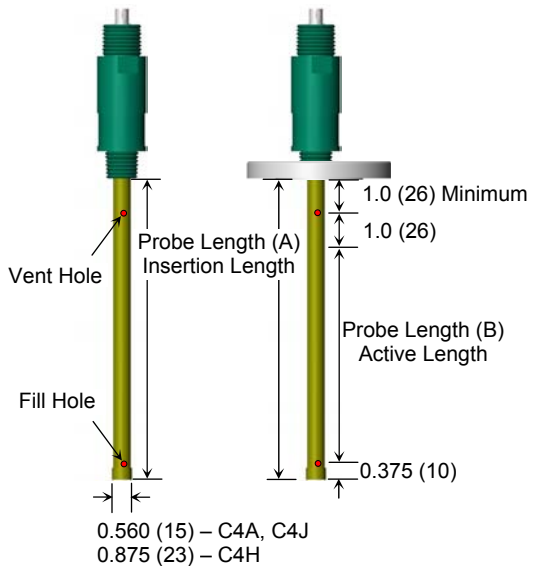

Cryosense™ Probes

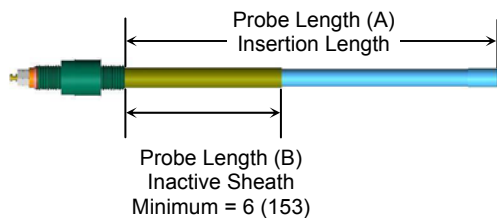

Inactive Sheath Probe

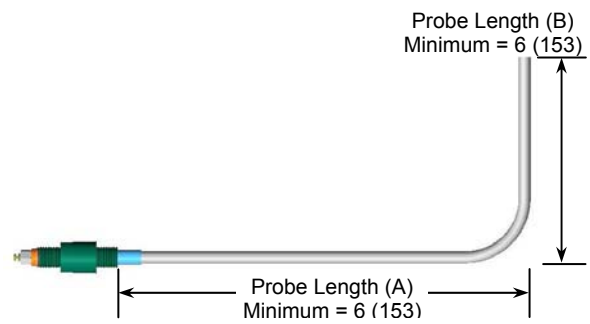

Bent Probes

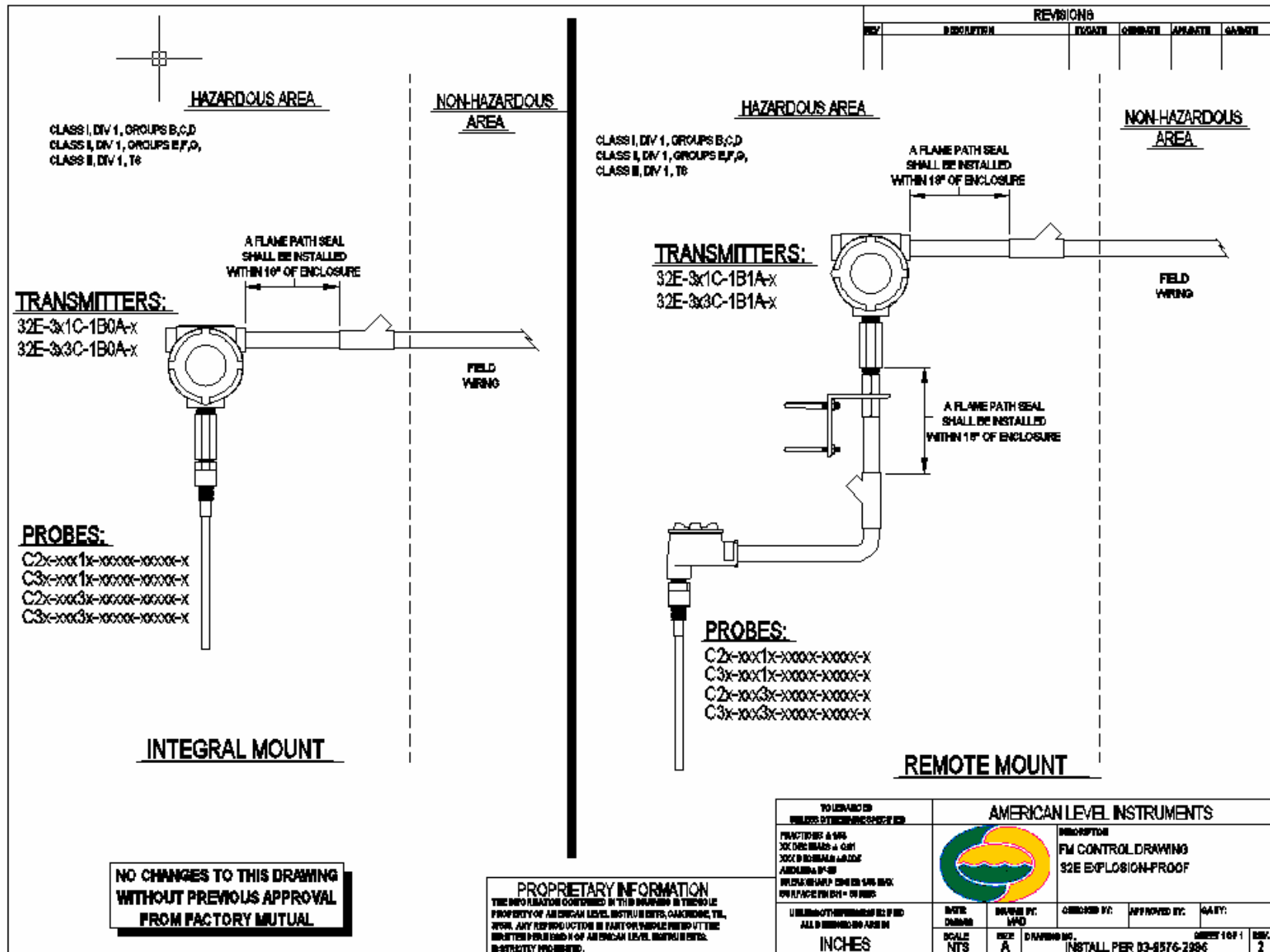

HAZARDOUS AREA

CLASS I, DIV 1, GROUPS A,B,C,D
CLASS II, DIV 1, GROUPS E,F,G,
CLASS II, DIV 1, T4

CLASS I, DIV 2, GROUPS A,B,C,D
CLASS II, DIV 2, GROUPS F,G,
CLASS II, DIV 2, T4
(NOTE 2)

TRANSMITTERS:

32E-3x2C-1B0A-x
32E-3x3C-1B0A-x

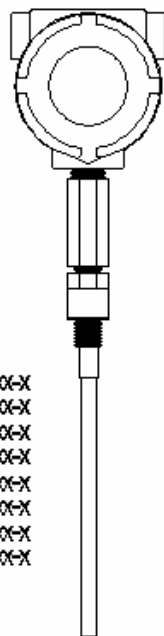

PROBES:

- C1x-xxx2x-xxxxx-xxxxx-x
- C2x-xxx2x-xxxxx-xxxxx-x
- C3x-xxx2x-xxxxx-xxxxx-x
- C4x-xxx2x-xxxxx-xxxxx-x
- C1x-xxx3x-xxxxx-xxxxx-x
- C2x-xxx3x-xxxxx-xxxxx-x
- C3x-xxx3x-xxxxx-xxxxx-x
- C4x-xxx3x-xxxxx-xxxxx-x

ENTITY:

$V_{max} = 25Vdc$
 $I_{max} < 125mA$
 $C_1 = 0$
 $L_1 = 0$
 $P_1 = 1W$

INTRINSICALLY SAFE / NON-INCENDIVE

REVISIONS					
REV	DESCRIPTION	DATE	APPROVE	DATE	BY

NON-HAZARDOUS AREA

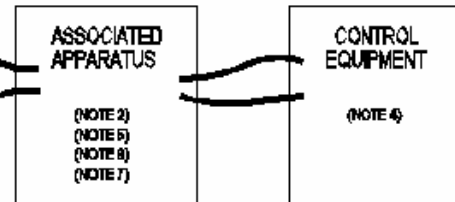

NOTES:

- 1) THE INTRINSIC SAFETY ENTITY CONCEPT ALLOWS THE INTERCONNECTION OF TWO INTRINSICALLY SAFE DEVICES FM APPROVED WITH ENTITY PARAMETERS NOT SPECIFICALLY EXAMINED IN COMBINATION AS A SYSTEM WHEN:
 U_0 OR V_{00} OR $V_1 \leq V_{max}$, I_0 OR I_{00} OR $I_1 \leq I_{max}$, C_0 OR $C_0 + C_{cable}$, L_0 OR $L_0 + L_1 + L_{cable}$, $P_0 \leq P_1$
- 2) FOR DIVISION 2 INSTALLATIONS, THE ASSOCIATED APPARATUS IS NOT REQUIRED TO BE FM APPROVED UNDER ENTITY CONCEPT IF THE (PRODUCT NAME) IS INSTALLED IN ACCORDANCE WITH THE NATIONAL ELECTRICAL CODE® (ANSI/NFPA 70) FOR DIVISION 2 WIRING METHODS EXCLUDING NONINCENDIVE FIELD WIRING.
- 3) DUST-TIGHT CONDUIT SEAL SHALL BE USED WHEN INSTALLED IN CLASS I AND CLASS II ENVIRONMENTS.
- 4) CONTROL EQUIPMENT CONNECTED TO THE ASSOCIATED APPARATUS SHALL NOT USE OR GENERATE MORE THAN 250 Vrms OR Vdc.
- 5) DIVISION 1 INSTALLATIONS SHOULD BE IN ACCORDANCE WITH ANSISA RPM2.06.01 "INSTALLATION OF INTRINSICALLY SAFE SYSTEMS FOR HAZARDOUS (CLASSIFIED) LOCATIONS" AND THE NATIONAL ELECTRICAL CODE (ANSI/NFPA 70).
- 6) FOR DIVISION 1 INSTALLATIONS, THE CONFIGURATION OF ASSOCIATED APPARATUS SHALL BE FM APPROVED UNDER ENTITY CONCEPT.
- 7) ASSOCIATED APPARATUS MANUFACTURER'S INSTALLATION DRAWING SHALL BE FOLLOWED WHEN INSTALLING THIS EQUIPMENT.
- 8) NO REVISION TO DRAWING WITHOUT PRIOR APPROVAL BY FM APPROVALS.
- 9) NOMINAL POWER SUPPLY VOLTAGE = 24Vdc.
- 10) THIS TRANSMITTER CAN ALSO BE INSTALLED IN DIVISION 2 HAZARDOUS AREAS WITHOUT THE NEED FOR CONNECTION TO A PROTECTIVE BARRIER WHEN INSTALLED PER THE NATIONAL ELECTRIC CODE (NEC), AND WHEN CONNECTED TO A POWER SOURCE NOT EXCEEDING 20Vdc.

NO CHANGES TO THIS DRAWING WITHOUT PREVIOUS APPROVAL FROM FACTORY MUTUAL.

PROPRIETARY INFORMATION
THE INFORMATION CONTAINED IN THIS DRAWING IS THE SOLE PROPERTY OF AMERICAN LEVEL INSTRUMENTS, CINCINNATI, OH, U.S.A. ANY REPRODUCTION IN PART OR ENTIRETY OF THIS DRAWING WITHOUT THE WRITTEN PERMISSION OF AMERICAN LEVEL INSTRUMENTS, CINCINNATI, OH, U.S.A. IS STRICTLY PROHIBITED.

AMERICAN LEVEL INSTRUMENTS 		DIBAO NPTD II FM CONTROL DRAWING 32E I.S. & NI	
CHECKED BY: DATE: 08/08/08 SCALE: NTS	DESIGNED BY: LMD SIZE: A DRAWING NO.:	APPROVED BY:	REV: 2