



## Industrial RF Capacitance Probes

(See Also AMI Model 32E Instrument Literature)

American Magnetics' RF Capacitance probes are designed to provide reliable and consistent measurement of media level in your process. The probes discussed in this brochure are designed to be used with the AMI Model 32E Industrial Liquid Level Transmitter.

FEATURES	BENEFITS OF OWNERSHIP
Heavy-duty construction on all probe styles	Durability / Safety
Leak-proof, self-adjusting process seal ( <i>Bare &amp; Insulated styles</i> )	Reliability / Safety
Cryosense™ Probes – specifically designed for cryogenic fluids	Solution for a difficult application
Field adjustable probe length ( <i>Bare styles</i> )	Simplifies ordering

### Applications

- Oils, Solvents
- Other Hydrocarbons
- Water
- Slurries
- Liquid-Liquid Interfaces
- Cryogenic Fluids



### Principle of Operation

The probe, in conjunction with the vessel wall and the process media (dielectric), form a capacitor. As the level of the media changes, a corresponding change in capacitance occurs. This change in capacitance is processed by the instrument and provides an output equivalent to the level in the vessel. In conductive media applications, the probe and the process media are the capacitive plates and the insulation (Teflon®) on the probe is the dielectric.

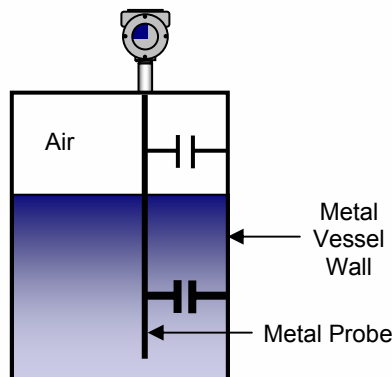

Non-conductive / Low Dielectric Media

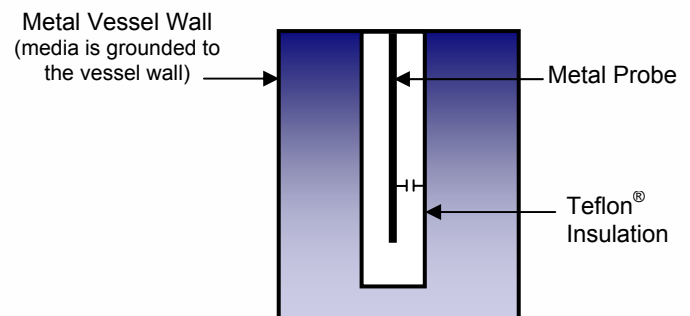

Conductive / High Dielectric Media  
(Close-up of probe bottom)

Bringing Solutions to Science & Industry





## Process Media

To select the correct probe for an application, it is important to classify the process media as either Non-conductive (low dielectric) or Conductive (high dielectric).

**Non-conductive Media** (conductivity of less than 10 μsiemens/cm; a dielectric constant less than 10): solvents, oils, hydrocarbons, and cryogenic fluids fall into this category.

**Conductive Media** (conductivity of 10μsiemens or greater; a dielectric constant of 10 or greater): Acids, caustics, and fluids containing water, fall into this category.

## Probe Types

A typical probe consists of a probe rod, a process connection, and a seal. There are three basic probe families: Bare, Insulated, and Cryogenic (Cryosense™). Each probe is designed for specific application conditions. Following are a descriptions of the various probe types within these families.

### Non-Conductive Media:

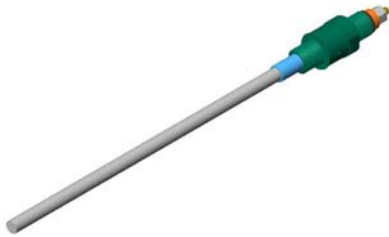

#### **BARE PROBE (MODELS C1A & C1F)**

Bare Probes are used in non-conductive media. The rods are 1/2" in diameter, and have a maximum length of 234". The probes can be bent (Model C1F) to 90° at the factory. A bent probe can provide a vertical configuration, when a horizontal connection is used. Typical process connection is 3/4" NPT.

#### **BARE STILLWELL PROBE (MODEL C1D)**

Bare Stillwell Probes are used in non-conductive media to provide a linear reference to the process media in applications involving non-parallel vessel walls (bullet tanks), non-metallic vessels, or when the probe is mounted more than 10" away from the vessel wall. They can also provide some damping in heavy turbulence processes. Use in fluids with a viscosity less than 250 centipoise. Typical process connection is 1" NPT.



#### **CRYOSENSE™ CRYOGENIC PROBES (MODELS C4A, C4H, & C4J)**

Cryosense™ Probes are specifically designed for the measurement of cryogenic liquids. The C4A probe is used in a variety of cryogenic liquids. The C4H is specially designed for Liquid Hydrogen, and for higher resolution in other cryogenic liquids. The C4J is similar to the C4A, but with special materials designed not to ignite in Liquid Oxygen. Typical process connection is 3/4" NPT.

## American Magnetics, Inc.

P.O. Box 2509 \* 112 Flint Road \* Oak Ridge, TN 37831-2509

Phone: (865) 482-1056 \* Fax: (865) 482-5472

E-mail: [sales@americanmagnetics.com](mailto:sales@americanmagnetics.com)

[www.americanmagnetics.com](http://www.americanmagnetics.com)



## Conductive Media Probes:

### **INSULATED PROBE (MODELS C2A & C2F)**

Insulated probes are used in conductive media. The probe consists of a 1/2" diameter metal rod, insulated with PFA Teflon® to a diameter of 5/8". The maximum length is 234". The probes can be bent (Model C2F) to 90° at the factory. A bent probe can provide a vertical configuration, when a horizontal connection is used. Typical process connection is 3/4" NPT.

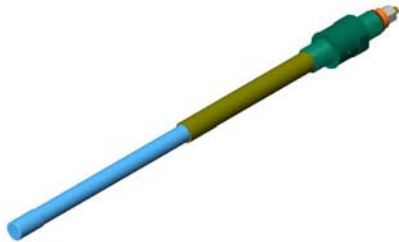
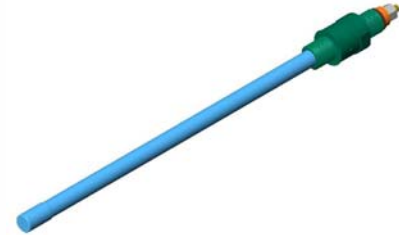

### **INSULATED INACTIVE SHEATH PROBE (MODEL C2B)**

The "Inactive Sheath" blocks the upper portion of the probe from registering any capacitance change. This is useful if the probe is horizontally mounted in a nozzle, preventing any debris or "build-up" from causing a false level indication. It is also used in liquid-liquid interface applications to block the air / oil interface, allowing the instrument to measure the oil / water interface. Typical process connection is 3/4" NPT.

### **INSULATED REFERENCE WIRE PROBE (MODEL C2C)**

Reference wire probes are used in conductive media to provide a reference to the process media in non-metallic vessels. This probe is limited to clean liquids, as any "build-up" on the wire will result in a measurement error. Typical process connection is 3/4" NPT.

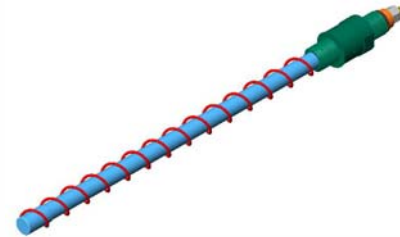

### **INSULATED STILLWELL PROBE (MODEL C2D)**

Insulated Stillwell Probes are used in conductive media to provide a reference to the process media in non-metallic vessels. They can also provide some damping in heavy turbulence processes. Use in fluids with a viscosity less than 250 centipoise. Typical process connection is 1" NPT.



## Probe Selection

Selecting the right probe for your application is the most important part of applying an RF Capacitance system for your process. Using the flowcharts below, you will be able to select a probe that will provide a linear capacitance change, as well as maximizing the amount of capacitance per unit level change. These flowcharts are to be used as a guideline only. Contact American Magnetics at (865) 482-1056 for applications assistance.

### General Guidelines

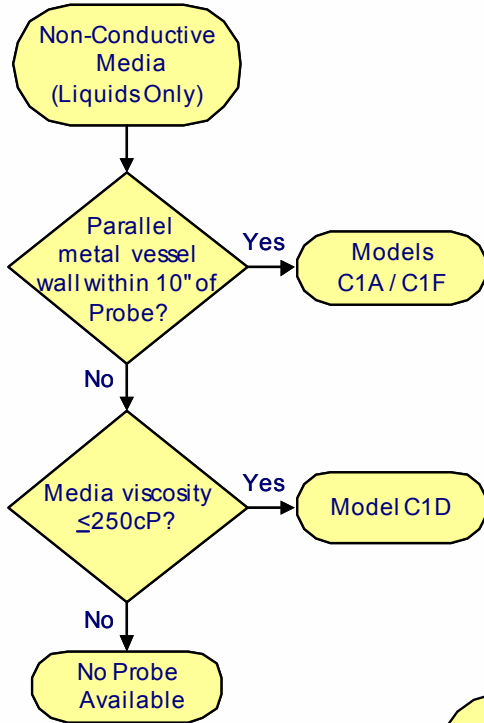

- Use Bare probes for non-conductive media
- Use Insulated probes for conductive media. If uncertain of the conductivity value, use an Insulated probe.
- Use Cryosense™ probes for cryogenic fluid applications.
- Use an Inactive Sheath probe for liquid-liquid interface applications.
- Use a Reference probe when measuring non-conductive media in a vessel where the distance is not constant (parallel) from the probe, or if the probe will be mounted more than 10" (254mm) from the vessel wall. A "Reference" probe provides both plates of the capacitor, eliminating the use of the vessel wall, and must be used when measuring any media in a non-metallic vessel.

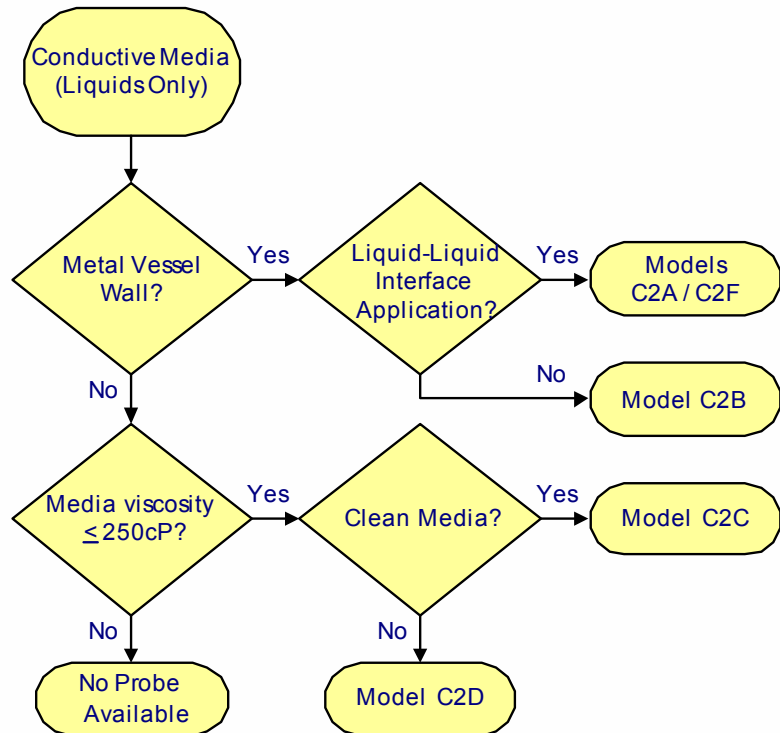

## American Magnetics, Inc.

P.O. Box 2509 \* 112 Flint Road \* Oak Ridge, TN 37831-2509

Phone: (865) 482-1056 \* Fax: (865) 482-5472

E-mail: [sales@americanmagnetics.com](mailto:sales@americanmagnetics.com)

[www.americanmagnetics.com](http://www.americanmagnetics.com)

## Probe Specifications

Description	Specification
Process Temperature Range @ 1psig (1bar)	C1x -100°F to 400°F (-73°C to 204°C)
	C2x -100°F to 400°F (-73°C to 204°C)
	C4A -430°F to 180°F (-257°C to 82°C)
	C4H -430°F to 250°F (-257°C to 121°C)
	C4J -430°F to 400°F (-257°C to 204°C)
Process Pressure Range @ 100°F (37°C)	C1x Vacuum to 2,000 psig (0 bar to 139 bar)
	C2x Vacuum to 2,000 psig (0 bar to 139 bar)
	C4x Vacuum to 1,000 psig (0 bar to 70 bar)

## Agency Approvals\*

Agency	Models	Protection Method	Approval
Factory Mutual (FM)	C2x-xxx3x-xxxxx-xxxxx-x	**Explosion-proof (XP, I.S. and N.I.)	Division 1 Class I; Groups B, C, D
	Cxx-xxx2x-xxxxx-xxxxx-x C2x-xxx3x-xxxxx-xxxxx-x	Intrinsically Safe and Non-Incendive (I.S. and N.I.)	Division 1 and Division 2 Class I; Groups A, B, C, D

\*Class II and Class III applications are no longer supported.

Two available approval combinations:

1. All probes are Approved for Intrinsically Safe and Non-Incendive (I.S. and N.I.) applications.
2. In addition, C2x probes are Approved for Explosion Proof, i.e., XP, I.S., and N.I. applications.
3. Customer is responsible for determining required level of approval.

\*\*Maximum Ambient Temperature for XP Installations: 140°F (60°C).

## Application Examples

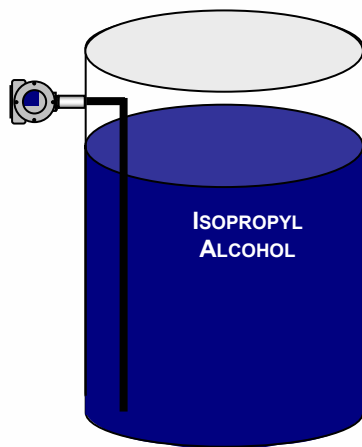

### Conductive Liquid

This is the simplest of all applications. Select a standard insulated (C2A / C2F) probe if the vessel is metal. For non-metal vessels, use an insulated, reference wire (C2C) probe (clean liquid, viscosity less than 250cP), or an insulated, stillwell (C2D) probe (dirty liquid, viscosity less than 250cP). In this particular application, a bent, insulated probe (C2F) was selected because the only available process connection was on the side of the vessel, and the vessel is metal.

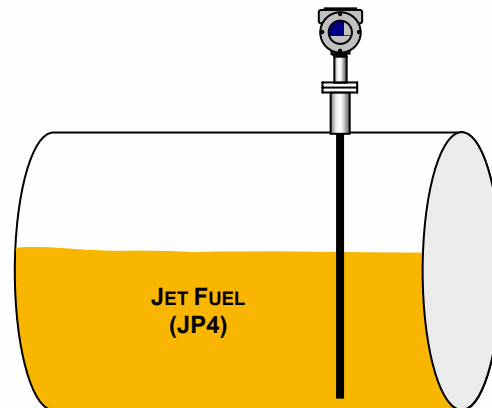

### Non-Conductive Liquid

When measuring a non-conductive liquid, the geometry of the vessel must be considered. It is essential that there be a parallel, conducting wall or surface within 10" of the probe. The solution is to use a bare, stillwell (C1D) probe. The integrated stillwell provides a linear reference. In this application (horizontal cylinder), the wall of the vessel is curved providing a variable distance from the probe, with a resulting non-linear capacitance.

## American Magnetics, Inc.

P.O. Box 2509 \* 112 Flint Road \* Oak Ridge, TN 37831-2509

Phone: (865) 482-1056 \* Fax: (865) 482-5472

E-mail: [sales@americanmagnetics.com](mailto:sales@americanmagnetics.com)

[www.americanmagnetics.com](http://www.americanmagnetics.com)



## Application Examples (cont.)

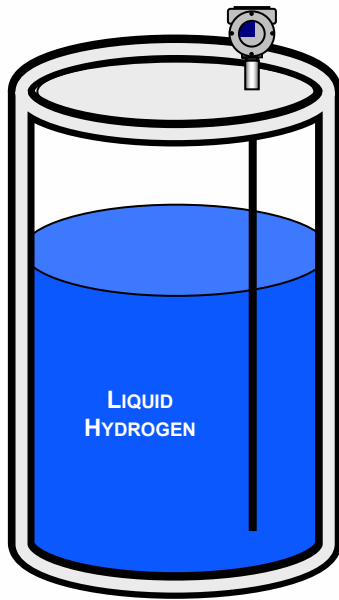

### Cryogenic Liquid

Cryosense™ probes are specially designed for use in cryogenic liquids. The best choice for this application is the liquid hydrogen (C4H) probe. The extremely low dielectric constant (1.2) of liquid hydrogen is beyond the capabilities of most capacitance probes.

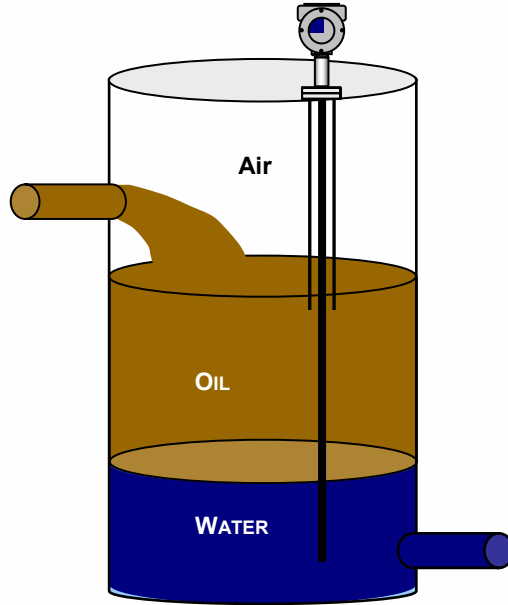

### Liquid-Liquid Interface

The key to a successful oil/water interface application, is to insure that the probe only “sees” the oil/water interface, not the air/oil interface. The insulated, inactive sheath (C2B) probe is designed for this purpose. The length of the inactive sheath must be long enough to extend into the oil layer, but short enough to stay out of the water layer. If in doubt, shorter is better because the air layer will only add a small error to the measurement.

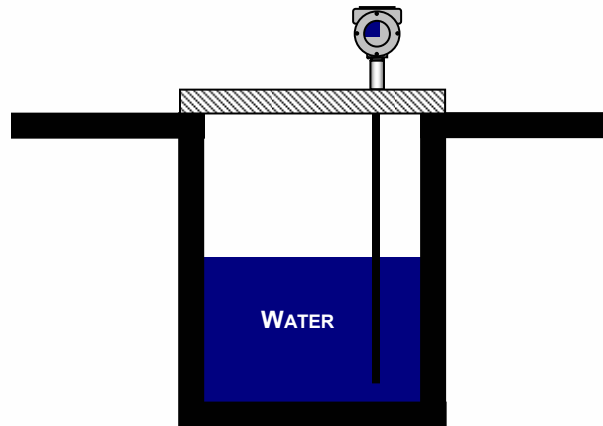

### Concrete Sump

This sump contains clean, run-off water. An Insulated probe is used because the media is conductive. However, since the vessel walls are concrete (non-metallic), a reference probe is needed. While, an insulated, stillwell probe (C2D) can be used, the most cost-effective solution is the insulated reference wire (C2C) probe.

## American Magnetics, Inc.

P.O. Box 2509 \* 112 Flint Road \* Oak Ridge, TN 37831-2509

Phone: (865) 482-1056 \* Fax: (865) 482-5472

E-mail: [sales@americanmagnetics.com](mailto:sales@americanmagnetics.com)

[www.americanmagnetics.com](http://www.americanmagnetics.com)



## Industrial Grade Probe Model Configuration

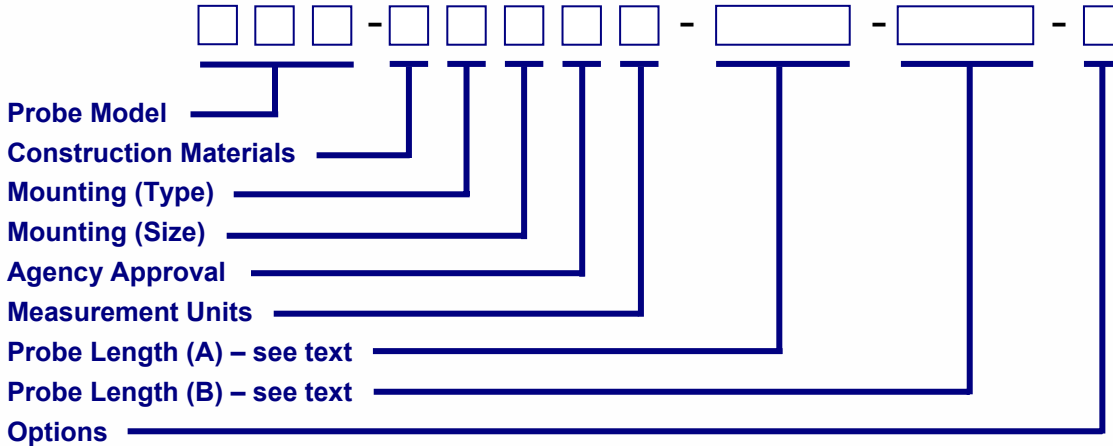

### Probe Model

Description	Code
Bare Rod	C1A
Bare Stillwell	C1D
Bare Bent Rod	C1F
Insulated Rod	C2A
Insulated Inactive Sheath	C2B
Insulated Reference Wire	C2C
Insulated Stillwell	C2D
Insulated Bent Rod	C2F
Cryogenic Liquid	C4A
Liquid Hydrogen (Cryogenic)	C4H
Liquid Oxygen (Cryogenic)	C4J

### Construction Materials

Description	Code
316 SS (C1x)	0
304 SS (C4x)	7
316 SS w/ Teflon® (C2x)	A

### Mounting Type

Description	Code
NPT	A
150# ANSI Flange	B
300# ANSI Flange	C
600# ANSI Flange	D
Sanitary Fitting (C2A)	E
Conflat (C4x)	1

### Mounting Size

Description	Code
1/2" (ANSI Flange), (NPT – C4A & C4J)	A
1.33" (Conflat)	B
2-1/8" (Conflat)	C
2-3/4" (Conflat)	D
3/4" (ANSI Flange & NPT)	0
1" (ANSI Flange, NPT, & Sanitary)	1
1-1/2" (ANSI Flange, NPT, & Sanitary)	5
2" (ANSI Flange, NPT, & Sanitary)	2
3" (ANSI Flange & NPT)	3
4" (ANSI Flange & NPT)	4
6" (ANSI Flange & NPT)	6
8" (ANSI Flange & NPT)	8

### Agency Approval\*

Description	Code
FM Intrinsically Safe (I.S.) & N.I. (All Probes)	2
FM XP, I.S., & N.I. (C2x Probes)	3

### Measurement Units

Description	Code
Inches	0
Feet	1
Millimeters	2
Meters	3

### Options

Description	Code
None	0
Seal Weld (ANSI Flanges)	1

\*Selected Approval must match that of Model 32E Instrument.

### Probe Length (A)

This field represents the insertion length of the probe, defined as the length of the probe measured from the bottom of the mounting connection to the bottom tip. Probes are available in lengths up to 234". For C4x probes, the minimum insertion length is Probe Length (B) + 2-3/8". For C1F and C2F probes, this is the 'A' dimension. Probe length fields are fixed as follows: xxx.x inches, xxx.x feet, xx.xx meters, and xxxxx millimeters. Use leading zeros if necessary to supply all five characters (the decimal point counts as a character).

### Probe Length (B)

This dimension is used for C1F, C2F, C2B, and C4x probes only. For C2B probes, it is the length of the inactive sheath. For the C1F and C2F probes, it is the 'B' dimension. The maximum length is limited by the formula: 'A' dim. + 'B' dim. + 3" ≤ 234". For C4x probes, this field represents the Active Length, which is defined as the measurement range of the probe. It starts 3/8" above the bottom tip of the probe, and ends 1" below the uppermost vent hole on the probe. Probe length fields are fixed as follows: xxx.x inches, xxx.x feet, xx.xx meters, and xxxxx millimeters. Use leading zeros if necessary to supply all five zeros if necessary to supply all five characters (the decimal point counts as a character). For probes not using this field, fill this space with zeros using the length format from Probe Length (A).

## American Magnetics, Inc.

P.O. Box 2509 \* 112 Flint Road \* Oak Ridge, TN 37831-2509

Phone: (865) 482-1056 \* Fax: (865) 482-5472

E-mail: sales@americanmagnetics.com

[www.americanmagnetics.com](http://www.americanmagnetics.com)

**Dimensions – inches (mm)**

**Bare & Insulated Probes**

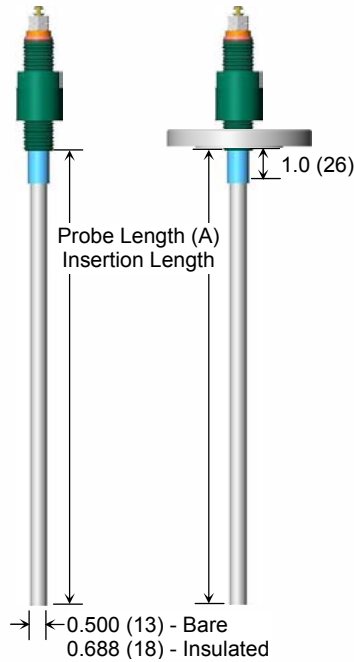

**Cryosense™ Probes**

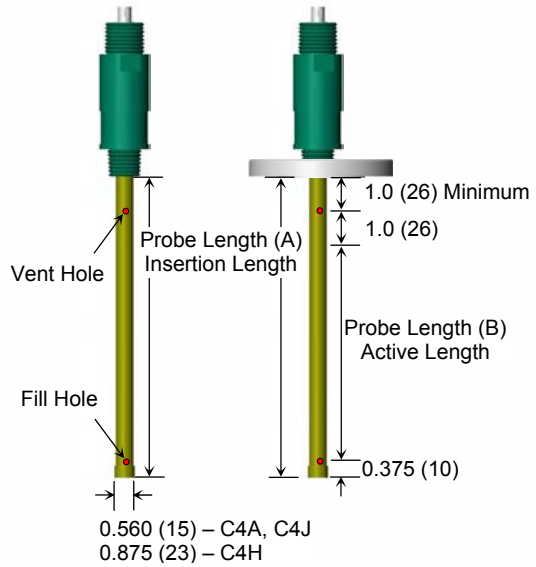

**Inactive Sheath Probe**

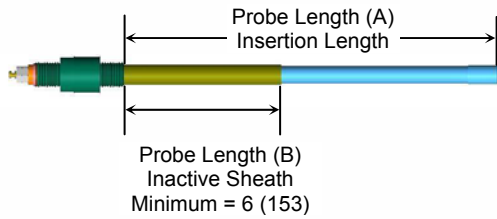

**Bent Probes**

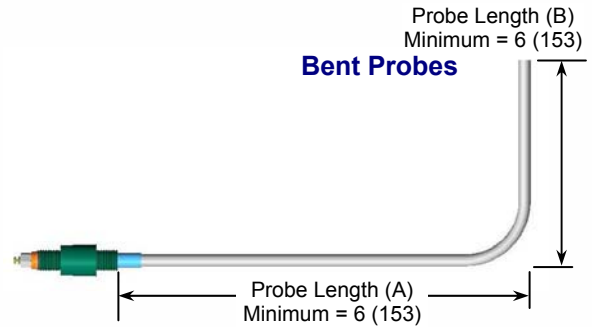

**How to Proceed**

Selecting an RF Capacitance probe is easy:

1. Complete the attached Applications Data Sheet.
2. Return the sheet for evaluation.

An experienced Applications Engineer will evaluate your application, and select the best probe to meet your needs. It is that simple.



# American Magnetics, Inc.

P.O. Box 2509, 112 Flint Road, Oak Ridge, TN 37831-2509  
Phone: (865) 482-1056 Fax: (865) 482-5472  
Internet: <http://www.americanmagnetics.com> E-mail: [sales@americanmagnetics.com](mailto:sales@americanmagnetics.com)

## Application Data Sheet

**Please fill-in all available data and fax or e-mail to AMI**

1. Company: \_\_\_\_\_ Contact: \_\_\_\_\_ Title: \_\_\_\_\_  
 Street: \_\_\_\_\_ City: \_\_\_\_\_ State: \_\_\_\_\_ Zip Code: \_\_\_\_\_  
 Country: \_\_\_\_\_ Phone #: \_\_\_\_\_ Fax #: \_\_\_\_\_  
 E-Mail: \_\_\_\_\_

2. Process Media(s): \_\_\_\_\_  
 Type:  Liquid  Slurry: H<sub>2</sub>O: \_\_\_\_\_%  Liquid-Liquid Interface

3. Temperature: *Process*: \_\_\_\_\_°F max; \_\_\_\_\_°F min *Ambient*: \_\_\_\_\_°F max; \_\_\_\_\_°F min

4. Environment:  Outside  Inside

5. Pressure: \_\_\_\_\_(psig) max; \_\_\_\_\_(psig) min

6. Dielectric Constant: \_\_\_\_\_ Conductivity: \_\_\_\_\_µsiemens Viscosity: \_\_\_\_\_Centipoise

7. Agitation: Yes / No Media Buildup: Yes / No; If yes, anticipated thickness on sensor: \_\_\_\_\_in.  
(circle one) (circle one)

8. Vessel Construction:  All Metal  All Non-metallic  Lined: \_\_\_\_\_  Concrete  Other \_\_\_\_\_  
(lining material)

9. Tank Shape:  Vertical Cylinder  Sphere  
 Horizontal Cylinder

*Provide a drawing of the installation. Include all process connections and the sensor location. Show sensor distance from nearest vertical wall.*

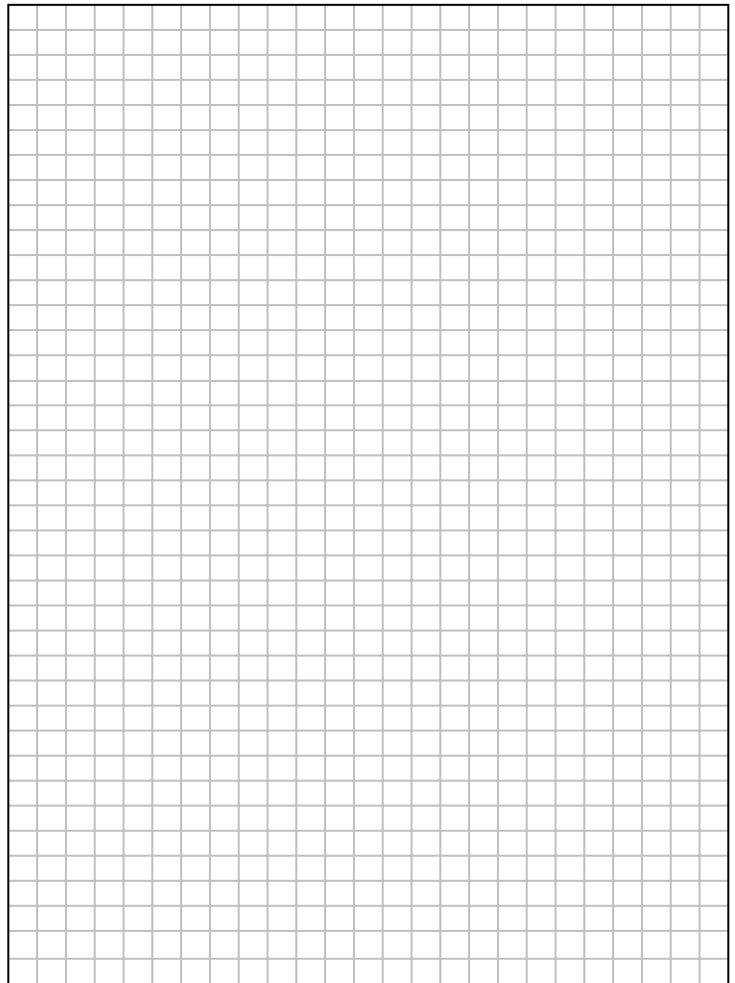

10. Tank Dimensions: Diameter \_\_\_\_\_ft./in.  
(circle one)  
 Height/Length \_\_\_\_\_ft./in.  
(circle one)

11. Measurement Extremes (show on sketch):  
 Distance between 100% level and tank top \_\_\_\_\_  
 Distance between 0% level and tank bottom \_\_\_\_\_

12. Instrument Type:  Point Level<sup>1</sup>  Continuous Level

13. Input Power:  100/120Vac<sup>2</sup>  200/240Vac<sup>2</sup>  
 24Vdc via Current Loop<sup>3</sup>

14. Analog Output:  4-20mA  0-10Vdc<sup>2</sup>

15. Digital Comm. Output<sup>2</sup>:  RS-232  RS-422  
 IEEE-488 (GPIB)

16. Dry Relay Contacts<sup>2</sup>:  Alarm

17. Sensor Material:  304 SST  316 SS  
 316 SS w/Teflon Insulation

18. Sensor Mounting: \_\_\_\_\_  
(size and type)

19. Electrical Hazardous Area: Yes / No  
(circle one)

20. FM Approval:  None<sup>4</sup>  
 Intrinsically Safe<sup>5</sup>  Explosion-proof<sup>6</sup>

1. Available only on the Model 160.  
 2. Not available for Industrial Instruments (Model 32E or Model 175).  
 3. Available only for Industrial Instruments (Model 32E or Model 175).  
 4. Not available for Model 32E Instrument or associated Cxx Probes.  
 5. Available only for Model 32E Instrument and associated Cxx Probe.  
 6. Available only for Model 32E Instrument and associated C2x Probe.